

Doddridge County Sheriff  
Flood Plain Ordinance Fund

1008

69-217/515

DATE July 2, 2013

PAY TO THE ORDER OF ANTERO RESOURCES

\$ 4,673.25

Four Thousand Six Hundred Seventy-Three Dollars and 25/100-----



DOLLARS Security features included. Details on back.

*Ralph Anderson*  
*Beth A. Rogers*

MEMO#13-013 Pearl Jean North reimbursement

⑈001008⑈ ⑆051502175⑆

1196499⑈

MP



**ANTERO RESOURCES APPALACHIAN**  
 1625 17th STREET, SUITE 300  
 DENVER, COLORADO 80202

Vendor Name	Vendor No.	Date	Check Number	Check Total
DODDRIDGE COUNTY COMMISSION	43312	Jun-18-2013	31797	\$4,866.58

VOUCHER	VENDOR INV #	INV DATE	TOTAL AMOUNT	PRIOR PMTS & DISCOUNTS	NET AMOUNT
06-AP-8194	ARLJEANNORTH	06/18/13	4,866.58	0.00	4,866.58
FLOOD PLAIN PERMIT - PEARL JEAN NORTH					
TOTAL INVOICES PAID					4,866.58

By: BH - MEH - AML  
 Asst. Chief Tax Deputy

Michael Headley  
 Sheriff of Doddridge County

The Person paying Money into the Treasury shall forthwith file one of these Receipts with the County Clerk

## Doddridge County, West Virginia

No. 4769

Date: June 25, 2013  
 \*\*\*Customer copy\*\*\*

Received: #13-013 Antero Resources \$4,866.58

In Payment For: 318 Building Permits (LP)

For: 12-Flood Plain Ordinanc Fund #20 Fund

By: BH - MEH - AML  
 Asst. Chief Tax Deputy

Michael Headley  
 Sheriff of Doddridge County

**Doddridge County Flood Plain Refund Calculator (if not in Flood Plain)**

Pearl Jean North

Estimated Construction Costs	\$673,315.00
Amount over \$100,000	\$573,315.00
Drilling Oil and Gas Well Fee	\$1,000.00
Deposit for additional charges	\$1,000.00
\$5 per \$1,000 over \$100,000	\$2,866.58
Amount Due with application	\$4,866.58
95% of Application Fee minus \$1,000 deposit	\$3,673.25
Cost for Permit	\$193.33
Total Refund (Includes 100% of 1,000 deposit)	\$4,673.25



June 18, 2013

Doddridge County Commission  
Attn: Dan Wellings, Doddridge County Floodplain Manager  
118 East Court Street, Room 102  
West Union, WV 26456

Antero Resources  
1625 17th Street  
Denver, Colorado 80202  
Office 303.357.7310  
Fax 303.357.7315

Mr. Wellings:

Antero Resources Appalachian Corporation (Antero) would like to submit a Doddridge County Floodplain permit application for our Pearl Jean North Centralized Impoundment. Our project is located in Doddridge County, Grant District and per FIRM map #54107C0145C, this location is not within the floodplain.

Attached you will find the following:

- Doddridge County Floodplain Permit Application
- FIRM Map
- A detailed set of plans signed by a WV licensed professional engineer
- Copies of other required permits
- Site Safety Plan

If you have any questions please feel free to contact me at (303) 357-6820.

Thank you in advance for your consideration.

Sincerely,

Shauna Redican  
Permit Representative  
Antero Resources Appalachian Corporation

Enclosures

AMERICAN BRIDGE & CONSTRUCTION  
CORPORATION  
1625 17TH STREET  
DENVER, CO 80202

2013 JUN 24 PM 4:08

FILE

# DODDRIDGE COUNTY FLOODPLAIN DEVELOPMENT PERMIT APPLICATION

## SECTION 1: GENERAL PROVISIONS (APPLICANT TO READ AND SIGN)

1. No work may start until a permit is issued.
2. The permit may be revoked if any false statements are made herein.
3. If revoked, all work must cease until permit is re-issued.
4. Development shall not be used or occupied until a Certificate of Compliance is issued.
5. The permit will expire if no work is commenced within six months of issuance.
6. Applicant is hereby informed that other permits may be required to fulfill local, state, and federal requirements.
7. Applicant hereby gives consent to the Floodplain Administrator/Manager or his/her representative to make inspections to verify compliance.
8. **I, THE APPLICANT CERTIFY THAT ALL STATEMENTS HEREIN AND IN ATTACHMENTS TO THIS APPLICATION ARE, TO THE BEST OF MY KNOWLEDGE, TRUE AND ACCURATE.**

APPLICANT'S SIGNATURE



DATE June 18, 2013

## SECTION 2: PROPOSE DEVELOPMENT (TO BE COMPLETED BY APPLICANT).

**IF THE APPLICANT IS NOT A NATURAL PERSON, THE NAME, ADDRESS, AND TELEPHONE NUMBER OF A NATURAL PERSON WHO SHALL BE APPOINTED BY THE APPLICANT TO RECEIVE NOTICE PURSUANT TO ANY PROVISION OF THE CURRENT DODDRIDGE COUNTY FLOODPLAIN ORDINANCE.**

Antero Resources Appalachian Corporation - Shauna Redican, Permit Representative

APPLICANT'S NAME:

\_\_\_\_\_

ADDRESS: 1625 17th Street, Denver, CO 80202

TELEPHONE NUMBER: Contact Shauna Redican: 303-357-6820

**BUILDER'S NAME:** Antero Resources Appalachian Corporation

**ADDRESS:** 1625 17th Street, Denver, CO 80202

**TELEPHONE NUMBER:** (303) 357-7310

**ENGINEER'S NAME:** Navitus Engineering, Inc. - Cyrus S. Kump

**ADDRESS:** 151 Windy Hill Lane

**TELEPHONE NUMBER:** 888-662-4185

**PROJECT LOCATION:**

**NAME OF SURFACE OWNER/OWNERS (IF NOT THE APPLICANT)**

Dean R. and Martha A. Pennington

**ADDRESS OF SURFACE OWNER/OWNERS (IF NOT THE APPLICANT)**

Rt. 2, Box 207, West Union, WV 26456

**DISTRICT:** Grant

**DATE/FROM WHOM PROPERTY**

**PURCHASED:** N/A

**LAND BOOK DESCRIPTION:**

**DEED BOOK REFERENCE:** DB 275 Pg 051

**TAX MAP REFERENCE:** TM 20/ Pcl 1, TM 17/ Pcl 28, TM 16/ Pcl 21

**EXISTING BUILDINGS/USES OF PROPERTY:** None

**NAME OF AT LEAST ONE ADULT RESIDING IN EACH RESIDENCE LOCATED UPON THE SUBJECT PROPERTY** Dean R. & Martha A. Pennington

**ADDRESS OF AT LEAST ONE ADULT RESIDING IN EACH RESIDENCE LOCATED UPON THE SUBJECT PROPERTY** Rt. 2, Box 207, West Union, WV 26456

To avoid delay in processing the application, please provide enough information to easily identify the project location.

**DESCRIPTION OF WORK (CHECK ALL APPLICABLE BOXES)**

**A. STRUCTURAL DEVELOPMENT**

**ACTIVITY**

**STRUCTURAL TYPE**

- New Structure
- Addition
- Alteration
- Relocation
- Demolition
- Manufactured/Mobil Home

- Residential (1 – 4 Family)
- Residential (more than 4 Family)
- Non-residential (floodproofing)
- Combined Use (res. & com.)
- Replacement

**B. OTHER DEVELOPMENT ACTIVITIES:**

- Fill                     Mining             Drilling             Pipelining
- Grading
- Excavation (except for STRUCTURAL DEVELOPMENT checked above)
- Watercourse Altercation (including dredging and channel modification)
- Drainage Improvements (including culvert work)
- Road, Street, or Bridge Construction            \*Access Road Construction as shown on page 6 of attached Pearl Jean North Design
- Subdivision (including new expansion)
- Individual Water or Sewer System
- Other (please specify)

**C. STANDARD SITE PLAN OR SKETCH**

1. SUBMIT ALL STANDARD SITE PLANS, IF ANY HAVE BEEN PREPARED.
2. IF STANDARD SITE PLANS HAVE NOT BEEN PREPARED:  
SKETCH ON A SEPARATE 8 ½ X 11 INCH SHEET OF PAPER THE SHAPE AND LOCATION OF THE LOT. SHOW THE LOCATION OF THE INTENDED CONSTRUCTION OR LAND USE INDICATING BUILDING SETBACKS, SIZE & HEIGHT. IDENTIFY EXISTING BUILDINGS, STRUCTURES OR LAND USES ON THE PROPERTY.
3. SIGN AND DATE THE SKETCH.

**ACTUAL TOTAL CONSTRUCTION COSTS OF THE COMPLETE DEVELOPMENT IRRESPECTIVE OF WHETHER ALL OR ANY PART OF THE SUBJECT PROPOSED CONSTRUCTION PROJECT IS WITHIN THE FLOODPLAIN \$ 673,315.00**

\*See attached Floodplain Calculation Fee

**D. ADJACENT AND/OR AFFECTED LANDOWNER**

1. NAME AND ADDRESS OF ALL OWNERS OF SURFACE TRACTS ADJACENT TO THE AREA OF THE SURFACE TRACT (UP & DOWN STREAM) UPON WHICH THE PROPOSED ACTIVITY WILL OCCUR AND ALL OTHER SURFACE OWNERS UP & DOWN STREAM) WHO OWN PROPERTY THAT MAY BE AFFECTED BY FLOODING AS IS DEMONSTRATED BY A FLOODPLAIN STUDY OR SURVEY (IF ONE HAS BEEN COMPLETED).

NAME: N/A \_\_\_\_\_  
 ADDRESS: \_\_\_\_\_  
 \_\_\_\_\_

NAME: \_\_\_\_\_  
 ADDRESS: \_\_\_\_\_  
 \_\_\_\_\_

NAME: \_\_\_\_\_  
 ADDRESS: \_\_\_\_\_  
 \_\_\_\_\_

NAME: \_\_\_\_\_  
 ADDRESS: \_\_\_\_\_  
 \_\_\_\_\_

1. NAME AND ADDRESS OF AT LEAST ONE ADULT RESIDING IN EACH RESIDENCE LOCATED UPON ANY ADJACENT PROPERTY AT THE TIME THE FLOODPLAIN PERMIT APPLICATION IS FILED AND THE NAME AND ADDRESS OF AT LEAST ONE ADULT RESIDING IN ANY HOME ON ANY PROPERTY THAT MAY BE AFFECTED BY FLOODING AS IS DEMONSTRATED BY A FLOODPLAIN STUDY OR SURVEY.

NAME: N/A \_\_\_\_\_  
 ADDRESS: \_\_\_\_\_  
 \_\_\_\_\_

NAME: \_\_\_\_\_  
 ADDRESS: \_\_\_\_\_  
 \_\_\_\_\_

NAME: \_\_\_\_\_  
 ADDRESS: \_\_\_\_\_  
 \_\_\_\_\_

NAME: \_\_\_\_\_  
 ADDRESS: \_\_\_\_\_  
 \_\_\_\_\_

**E. CONFIRMATION FORM**

THE APPLICANT ACKNOWLEDGES, AGREES, AND CONFIRMS THAT HE/IT WILL PAY WITHIN 30 DAYS OF RECEIPT OF INVOICE BY THE COUNTY FOR ALL EXPENSES RELATIVE TO THE PERMIT APPLICATION PROCESS GREATER THAN THE REQUIRED DEPOSIT FOR EXPENSES INCLUDING:

- (A) PERSONAL SERVICE OF PROCESS BY THE DODDRIDGE COUNTY SHERIFF AT THE RATES PERMITTED BY LAW FOR SUCH SERVICE.
- (B) SERVICE BY CERTIFIED MAIL RETURN RECEIPT REQUESTED.
- (C) PUBLICATION.



- (D) COURT REPORTING SERVICES AT ANY HEARINGS REQUESTED BY THE APPLICANT.
- (E) CONSULTANTS AND/OR HEARING EXPERTS UTILIZED BY DODDRIDGE COUNTY FLOODPLAIN ADMINISTRATOR/MANAGER OR FLOODPLAIN APPEALS BOARD FOR REVIEW OF MATERIALS AND/OR TESTIMONY REGARDING THE EFFICACY OF GRANTING OR DENYING THE APPLICANT'S FLOODPLAIN PERMIT.

NAME (PRINT): Anthony Smith

SIGNATURE: [Signature] DATE: 6/24/13

After completing SECTION 2, APPLICANT should submit form to Floodplain Administrator/Manager or his/her representative for review.

**SECTION 3: FLOODPLAIN DETERMINATION (to be completed by Floodplain Administrator/Manager or his/her representative)**

**THE PROPOSED DEVELOPMENT:**

THE PROPOSED DEVELOPMENT IS LOCATED ON:

FIRM Panel: 145  
 Dated: 10/04/2011

Is **NOT** located in a Specific Flood Hazard Area (Notify applicant that the application review is complete and **NO FLOODPLAIN DEVELOPMENT PERMIT IS REQUIRED**).

Is located in Special Flood Hazard Area.  
 FIRM zone designation \_\_\_\_\_  
 100-Year flood elevation is: \_\_\_\_\_ NGVD (MSL)

Unavailable

The proposed development is located in a floodway.  
 BFBM Panel No. \_\_\_\_\_ Dated \_\_\_\_\_

See section 4 for additional instructions.

SIGNED Don Williams

DATE 06/24/2013

**SECTION 4: ADDITIONAL INFORMATION REQUIRED (To be completed by Floodplain Administrator/Manager or his/her representative)**

The applicant must submit the documents checked below before the application can be processed.

- A plan showing the location of all existing structures, water bodies, adjacent roads, lot dimensions and proposed development.
- Development plans, drawn to scale, and specifications, including where applicable: details for anchoring structures, storage tanks, proposed elevation of lowest floor, (including basement or crawl space), types of water resistant materials used below the first floor, details of flood proffing of utilities located below the first floor and details of enclosures below the first floor. Also \_\_\_\_\_  
\_\_\_\_\_
- Subdivision or other development plans (If the subdivision or development exceeds 50 lots or 5 acres, whichever is the lesser, the applicant must provide 100-year flood elevations if they are not otherwise available).
- Plans showing the extent of watercourse relocation and/or landform alterations.
- Top of new fill elevation \_\_\_\_\_ Ft. NGVD (MSL).  
For floodproofing structures applicant must attach certification from registered engineer or architect.
- Certification from a registered engineer that the proposed activity in a regulatory floodway will not result in any increase in the height of the 100-year flood. A copy of all data and calculations supporting this finding must also be submitted.
- Manufactured homes located in a floodplain area must have a West Virginia Contractor's License and a Manufactured Home Installation License as required by the Federal Emergency Management Agency (FEMA).

Other:

---

---

---

**SECTION 5: PERMIT DETERMINATION (To be completed by Floodplain Administrator/Manager or his/her representative)**

I have determined that the proposed activity (type is or is not) in conformance with provisions of the Floodplain Ordinance adopted by the County Commission of Doddridge County on May 21, 2013. The permit is issued subject to the conditions attached to and made part of this permit.

SIGNED *Dan Walling* DATE 06/24/2013

If the Floodplain Administrator/Manager found that the above was not in conformance with the provisions of the Doddridge County Floodplain Ordinance and/or denied that application, the applicant may complete an appealing process below.

APPEALS: Appealed to the County Commission of Doddridge County?  Yes  No  
Hearing Date: \_\_\_\_\_  
County Commission Decision - Approved  Yes  No

CONDITIONS: \_\_\_\_\_  
\_\_\_\_\_  
\_\_\_\_\_  
\_\_\_\_\_

**SECTION 6: AS-BUILT ELEVATIONS (To be submitted by APPLICANT before Certificate of Compliance is issued).**

The following information must be provided for project structures. This section must be completed by a registered professional engineer or a licensed land surveyor (or attach a certification to this application).

COMPLETE 1 OR 2 BELOW:

- 1 Actual (As-Built) Elevation of the top of the lowest floor (including basement or crawl space is \_\_\_\_\_ FT. NGVD (MSL)
- 2 Actual (As Built) elevation of floodproofing is \_\_\_\_\_ FT. NGVD (MSL)

**Note: Any work performed prior to submittal of the above information is at risk of the applicant.**

**SECTION 7: COMPLIANCE ACTION (To be completed by the Floodplain Administrator/Manager or his/her representative).**

The Floodplain Administrator/Manager or his/her representative will complete this section as applicable based on inspection of the project to ensure compliance with the Doddridge County Floodplain Ordinance.

**INSPECTIONS:**

DATE: \_\_\_\_\_ BY: \_\_\_\_\_  
DEFICIENCIES ?      Y/N

COMMENTS \_\_\_\_\_  
\_\_\_\_\_  
\_\_\_\_\_  
\_\_\_\_\_  
\_\_\_\_\_

**SECTION 8: CERTIFICATE OF COMPLIANCE (To be completed by Floodplain Administrator/Manager or his/her representative).**

Certificate of Compliance issued: DATE: \_\_\_\_\_ BY: \_\_\_\_\_

**CERTIFICATE OF COMPLIANCE  
FOR DEVELOPMENT IN SPECIAL FLOOD HAZARD AREA  
(OWNER MUST RETAIN)**

PERMIT NUMBER: #13-013

PERMIT DATE: 6/24/2013

PURPOSE -

CONSTRUCTION LOCATION: \_\_\_\_\_

OWNER'S ADDRESS: \_\_\_\_\_  
\_\_\_\_\_  
\_\_\_\_\_

**THE FOLLOWING MUST BE COMPLETED BY THE FLOODPLAIN  
ADMINISTRATOR/MANAGER OR HIS/HER AGENT.**

**COMPLIANCE IS HEREBY CERTIFIED WITH THE REQUIREMENT OF THE  
FLOODPLAIN ORDINANCE ADOPTED BY THE COUNTY COMMISSION OF  
DODDRIDGE COUNTY ON MAY 21, 2013.**

SIGNED  DATE 06/24/2013

**ANTERO RESOURCES APPALACHIAN CORPORATION**  
**SCHEDULE OF QUANTITIES**  
**PEARL JEAN NORTH**  
**CENTRALIZED FRESHWATER IMPOUNDMENT**

CLEARING & GRUBBING, EROSION & SEDIMENT CONTROLS				
	QUANTITY	UNIT		
MOBILIZATION	0.5	EA	\$16,000.00	\$8,000.00
CONSTRUCTION ENTRANCE	1.0	EA	\$4,033.30	\$4,033.30
CLEARING & GRUBBING (OPEN FIELD)	15.0	AC	\$2,200.00	\$33,000.00
CLEARING & GRUBBING (TREE REMOVAL)	5.0	AC	\$4,333.30	\$21,666.50
8" COMPOST FILTER SOCK	0.0	LF		\$0.00
12" COMPOST FILTER SOCK	3266.9	LF	\$4.30	\$14,047.67
18" COMPOST FILTER SOCK	661.3	LF	\$7.60	\$5,025.88
24" COMPOST FILTER SOCK	246.7	LF	\$9.80	\$2,417.66
32" COMPOST FILTER SOCK	581.9	LF	\$14.50	\$8,437.55
18" COMPOST FILTER SOCK DIVERSION	623.7	LF		\$0.00
SUPER SILT FENCE	0.0	LF	\$8.10	\$0.00
9" STRAW WATTLES	0.0	LF		\$0.00
<b>TOTAL</b>				<b>\$96,628.56</b>
SITE				
	QUANTITY	UNIT		
DRILL PAD EXCAVATION	0.0	CY		\$0.00
ACCESS ROADS EXCAVATION	34835.4	CY	\$3.50	\$121,923.90
TURNAROUND & STAGING PAD and/or CENTRALIZED IMPOUNDMENT EXCAVATION	46912.7	CY	\$3.50	\$164,194.45
TOPSOIL	8772.1	CY	\$3.30	\$28,947.93
DIVERSION DITCH	0.0	LF	\$2.00	\$0.00
ROADSIDE DITCH	3318.4	LF	\$3.70	\$12,278.08
<b>TOTAL</b>				<b>\$327,344.36</b>
SUMP(S) PER ANTERO RESOURCES STANDARD DETAIL				
	QUANTITY	UNIT		
INSTALL 102" x 78" x 44" PRE CAST SUMP - SEE ANTERO RESOURCES SUMP DETAIL	0.0	EA		\$0.00
VALVE BOX HDPE PIPE (MINIMUM 12" DIAMETER x 48" HEIGHT)	0.0	EA		\$0.00
4" PVC CONNECTIVE PIPE (ANTERO SUMP DRAIN DETAIL)	0.0	LF		\$0.00
<b>TOTAL</b>				<b>\$0.00</b>
AGGREGATE SURFACING - SPREADING, COMPACTION, and/or INSTALLATION				
	QUANTITY	UNIT		
DRILL PAD AASHTO #1 (8" THICK)	0.0	TON		\$0.00
DRILL PAD 1 1/2" or 3/4" CRUSHER RUN STONE (2" THICK)	0.0	TON		\$0.00
DRILL PAD GEOTEXTILE FABRIC (US 200)	0.0	SY		\$0.00
ACCESS ROADS 6" OR 4" MINUS CRUSHER RUN AGGREGATE (6" THICK)	2267.9	TON	\$9.40	\$21,318.26
ACCESS ROADS GEOTEXTILE FABRIC (US 200)	9071.4	SY	\$0.90	\$8,164.26
*INSTALL TENSAR TX190 GEOGRID or EQUIVALENT	0.0	SY	\$2.50	\$0.00
TURNAROUND & STAGING PAD 6" OR 4" MINUS CRUSHER RUN AGGREGATE (6" THICK)	1490.4	TON	\$2.60	\$3,875.04
TURNAROUND & STAGING PAD GEOTEXTILE FABRIC (US 200)	5961.6	SY	\$2.00	\$11,923.20
*INSTALL TENSAR TX190 GEOGRID or EQUIVALENT	0.0	SY		\$0.00
<b>TOTAL</b>				<b>\$45,280.76</b>

**ANTERO RESOURCES APPALACHIAN CORPORATION**  
**SCHEDULE OF QUANTITIES**  
**PEARL JEAN NORTH**  
**CENTRALIZED FRESHWATER IMPOUNDMENT**

<b>ROAD CULVERTS</b>				
	<b>QUANTITY</b>	<b>UNIT</b>		
15" HDPE	762.0	LF	\$24.30	\$18,516.60
18" HDPE	0.0	LF		\$0.00
24" HDPE	0.0	LF		\$0.00
30" HDPE	0.0	LF		\$0.00
36" HDPE	0.0	LF		\$0.00
42" HDPE	0.0	LF		\$0.00
48" HDPE	0.0	LF		\$0.00
60" HDPE	0.0	LF		\$0.00
R4 RIP RAP (INLETS/OUTLETS)	657.4	TON	\$9.00	\$5,916.60
AASHTO #1 STONE (DITCH CHECKS)	27.8	TON	\$48.30	\$1,342.74
DITCH LINING - (ACCESS ROAD) SYNTHETIC MATTING (TRM)	315.6	SY	\$3.40	\$1,073.08
DITCH LINING - (ACCESS ROAD)	0.0	SY		\$0.00
DITCH LINING - (ACCESS ROAD) R4 RIP-RAP	529.2	TON	\$21.70	\$11,483.64
<b>TOTAL</b>				<b>\$38,332.66</b>
<b>LINER SYSTEM*</b>				
	<b>QUANTITY</b>	<b>UNIT</b>		
60 MIL TEXTURED PRIMARY LINER	8544.1	SY		\$0.00
16 OZ. NON-WOVEN GEOTEXTILE FABRIC CUSHION	8544.1	SY		\$0.00
<b>TOTAL</b>				<b>\$0.00</b>
<b>*THE SQUARE YARDAGE FOR THE LINER SYSTEM DOES NOT ACCOUNT FOR MATERIAL OVERLAP AND WASTE.</b>				
<b>FENCING/GATES</b>				
	<b>QUANTITY</b>	<b>UNIT</b>		
4 FT WOVEN WIRE FARM FENCE w/MINIMUM 10 FT POST SPACING (WOODEN and/or "T" POST	1156.0	LF	\$16.80	\$19,420.80
16 FT DOUBLE GATE	1.0	EA	\$650.00	\$650.00
<b>TOTAL</b>				<b>\$20,070.80</b>
<b>SEEDING</b>				
	<b>QUANTITY</b>	<b>UNIT</b>		
SITE SEEDING (LIME, FERTILIZER, SEEDING, AND HYDRO-MULCH w/TACK (HYC-2 OR EQUAL))	17.2	AC	\$3,400.00	\$58,480.00
<b>TOTAL</b>				<b>\$58,480.00</b>
<b>UNFORESEEN SITE CONDITIONS</b>				
	<b>QUANTITY</b>	<b>UNIT</b>		
*ROCK CLAUSE - BLASTING	0.0	CY	\$5.20	\$0.00
*ROCK CLAUSE - HOE RAMMING	0.0	CY	\$75.80	\$0.00
*FRENCH DRAINS	0.0	FT	\$10.00	\$0.00
*PHASE 1 FENCING - STEEL CORRUGATED PANELS w/"T" POST (10 FT CENTERS) - WETLAND PROTECTION	0.0	LF	\$9.40	\$0.00
*PHASE 2 FENCING - SILT FENCE AND OR FILTER SOCK OUTSIDE OF PHASE 3 FENCING - WETLAND PROTECTION	0.0	LF	\$9.50	\$0.00
*PHASE 3 FENCING - ORANGE SAFETY FENCE w/"T" POST (10FT CENTERS) - WETLAND PROTECTION	0.0	LF	\$4.00	\$0.00
*SILT FENCE	0.0	LF	\$668.70	\$0.00
*TEMPORARY SEEDING	6.8	AC	\$1,900.00	\$12,920.00
*CONSTRUCTION STAKEOUT	0.0	HOUR	\$171.00	\$0.00
* JUTE MATTING - SLOPE MATTING	46411.0	SY	\$1.60	\$74,257.62
<b>TOTAL</b>				<b>\$87,177.62</b>
<b>GRAND TOTAL</b>				<b>\$673,314.75</b>



---

west virginia department of environmental protection

---

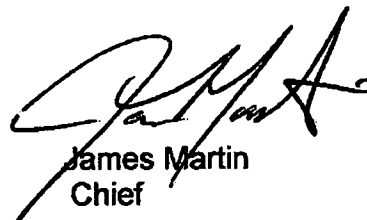
Office of Oil and Gas  
601 57<sup>th</sup> Street SE  
Charleston, WV 25304  
Telephone: (304) 926-0499  
Fax: (304) 926-0456

Earl Ray Tomblin, Governor  
Randy C. Huffman, Cabinet Secretary  
[www.dep.wv.gov](http://www.dep.wv.gov)

Date May 14, 2013  
**CERTIFICATE OF APPROVAL**  
**CENTRALIZED FRESHWATER IMPOUNDMENT**

This certificate of approval, number **017FWC00009**, issued to **Antero Resources Appalachian Corp for the Pearl Jean North Freshwater Centralized Impoundment**, is evidence of permission granted to construct a centralized freshwater impoundment pursuant to conditions described in W.Va Code §22-6A. The term of certificate of approval is for one year. The certificate of approval may be extended annually with the submission of an annual registration fee, provided the Office of Oil and Gas has on file an up-to-date inspection report, monitoring and emergency plan, maintenance plan, and no outstanding violations of certificate requirements exist. Construction of the impoundment will be located as described in the application. Design, construction, inspection and as-built certification will be the responsibility of, and under the supervision of, a professional engineer, registered in West Virginia.

Please be advised that notification to the landowner is required per W.Va Code §22-6A-10(h) within 7 days but no less than 2 days prior to commencement of construction. The Office of Oil and Gas as well as the oil and gas inspector must be notified. The filling of the impoundment with waters of the state will be subject to conditions of an approved Water Management Plan. Any deviation from conditions of the Water Management Plan will require prior approval from the Division of Water and Waste Management. Only freshwater may be stored in this impoundment. Addition of any wastewater will be in violation of the terms of this approval and may result in revocation of the certificate of approval. Any plans to enlarge, alter, repair, remove or abandon this structure will require a Certificate of Approval from the Office of Oil and Gas. An as built certification (IMP-3) must be submitted and received by the Office of Oil Gas prior to placing any fluids in this structure. Additional conditions as provide for in West Virginia Code §22-6A-9(h) are attached.



James Martin  
Chief

Promoting a healthy environment.



# Certificate of Approval

## CONDITIONS

West Virginia Code § 22-6A-9(h) allows the Office of Oil and Gas to place specific conditions upon this Certificate of Approval and have the same effect as law. Failure to adhere to the specified conditions may result in enforcement action.

---

### CONDITIONS

1. The impoundment shall be monitored continuously during the initial filling operation.
2. Impoundment will be inspected every two weeks for the life of the impoundment and within 24 hours of a rainfall of two inches or greater in a six hour period. The attached form shall be used to document all inspections performed on the structure.



# west virginia department of environmental protection



## Water Management Plan: Primary Water Sources



WMP-01175

API/ID Number: 017-FWC-00009

Operator:

Antero Resources

Pearl Jean North

### Important:

For each proposed primary water source (including source intakes for purchased water sources) identified in your water management plan, and summarized herein, DEP has made an evaluation concerning water availability over the specified date range. DEP's assessment is based on the following considerations:

- Statistical analysis of historical USGS stream gauge data (transferred to un-gauged locations as necessary);
- Identification of sensitive aquatic life (endangered species, mussels, etc.);
- Quantification of known existing demands on the water supply (Large Quantity Users);
- Minimum flows required by the Army Corps of Engineers; and
- Designated stream uses.

Based on these factors, DEP has provided, for each intake location (and origination point for purchased water), a reference gauge location and discharge flow reading which must be surpassed prior to withdrawals. Additionally, DEP has established a minimum passby flow at the withdrawal location which must also be surpassed prior to withdrawals. These thresholds are considered terms of the permit and are enforceable as such.

DEP is aware that some intake points will be used for multiple wells and well sites. In these cases, the thresholds set by the Water Management Plan are to be interpreted as total withdrawal limits for each location over the specified date range regardless of how many wells are supported by that intake.

For all purchased water intakes, determinations of water availability are made at the original source intake location. It is the responsibility of the Oil and Gas Operator, not the seller, to cease withdrawal of water from the seller when flows are less than the minimum gauge reading at the stream gauge referenced by the Water Management Plan in order to protect stream uses.

Note that the determinations made herein are based on the best available data, but it is impossible to predict water availability in the future. While the DEP has carefully established these minimum withdrawal thresholds, it remains the operator's responsibility to protect aquatic life at all times. Approval to withdrawal is contingent upon permission from the land owner. It is the responsibility of the operator to secure and maintain permission prior to any withdrawals.

The operator is reminded that 24-48 hours prior to withdrawing (or purchasing) water, DEP must be notified by email at [DEP.water.use@wv.gov](mailto:DEP.water.use@wv.gov).

APPROVED MAY 10 2013

### Source Summary

WMP 01175

API Number:

017-FWC-00009

Operator:

Antero Resources

Pearl Jean North

### Stream/River

\* Source **Ohio River @ Ben's Run Withdrawal Site**Owner: **Ben's Run Land Company  
Limited Partnership**

Start Date	End Date	Total Volume (gal)	Max. daily purchase (gal)	Intake Latitude:	Intake Longitude:
5/10/2013	5/10/2015			39.46593	-81.110781

 Regulated Stream? **Ohio River Min. Flow** Ref. Gauge ID: **9999999** **Ohio River Station: Willow Island Lock & Dam****Max. Pump rate (gpm): 3,360** **Min. Gauge Reading (cfs): 6,468.00** **Min. Passby (cfs)**DEP Comments: **Refer to the specified station on the National Weather Service's Ohio River forecast website: <http://www.erh.noaa.gov/ohrfc//flows.shtml>**\* Source **West Fork River @ JCP Withdrawal**Owner: **James & Brenda Raines**

Start Date	End Date	Total Volume (gal)	Max. daily purchase (gal)	Intake Latitude:	Intake Longitude:
5/10/2013	5/10/2015			39.320913	-80.337572

 Regulated Stream? **Stonewall Jackson Dam** Ref. Gauge ID: **3061000** **WEST FORK RIVER AT ENTERPRISE, WV****Max. Pump rate (gpm): 2,000** **Min. Gauge Reading (cfs): 175.00** **Min. Passby (cfs) 146.25**

DEP Comments:

\* Source **West Fork River @ McDonald Withdrawal**Owner: **David Shrieves**

Start Date	End Date	Total Volume (gal)	Max. daily purchase (gal)	Intake Latitude:	Intake Longitude:
5/10/2013	5/10/2015			39.16761	-80.45069

 Regulated Stream? **Stonewall Jackson Dam** Ref. Gauge ID: **3061000** **WEST FORK RIVER AT ENTERPRISE, WV****Max. Pump rate (gpm): 3,000** **Min. Gauge Reading (cfs): 175.00** **Min. Passby (cfs) 106.30**

DEP Comments:

● Source **West Fork River @ GAL Withdrawal**

Owner: **David Shrieves**

Start Date	End Date	Total Volume (gal)	Max. daily purchase (gal)	Intake Latitude:	Intake Longitude:
5/10/2013	5/10/2015			39.16422	-80.45173

Regulated Stream? **Stonewall Jackson Dam** Ref. Gauge ID: **3061000** **WEST FORK RIVER AT ENTERPRISE, WV**

**Max. Pump rate (gpm): 2,000** **Min. Gauge Reading (cfs): 175.00** **Min. Passby (cfs) 106.30**

DEP Comments:

● Source **Middle Island Creek @ Dawson Withdrawal**

Owner: **Gary D. and Rella A. Dawson**

Start Date	End Date	Total Volume (gal)	Max. daily purchase (gal)	Intake Latitude:	Intake Longitude:
5/10/2013	5/10/2015			39.379292	-80.867803

Regulated Stream? Ref. Gauge ID: **3114500** **MIDDLE ISLAND CREEK AT LITTLE, WV**

**Max. Pump rate (gpm): 3,000** **Min. Gauge Reading (cfs): 76.03** **Min. Passby (cfs) 28.83**

DEP Comments:

● Source **McElroy Creek @ Forest Withdrawal**

Owner: **Forest C. & Brenda L. Moore**

Start Date	End Date	Total Volume (gal)	Max. daily purchase (gal)	Intake Latitude:	Intake Longitude:
5/10/2013	5/10/2015			39.39675	-80.738197

Regulated Stream? Ref. Gauge ID: **3114500** **MIDDLE ISLAND CREEK AT LITTLE, WV**

**Max. Pump rate (gpm): 1,000** **Min. Gauge Reading (cfs): 74.77** **Min. Passby (cfs) 13.10**

DEP Comments:

Source **McElroy Creek @ Sweeney Withdrawal** Owner: **Bill Sweeney**

Start Date: 5/10/2013 End Date: 5/10/2015 Total Volume (gal): Max. daily purchase (gal): Intake Latitude: 39.398123 Intake Longitude: -80.656808

Regulated Stream? Ref. Gauge ID: 3114500 MIDDLE ISLAND CREEK AT LITTLE, WV

Max. Pump rate (gpm): 1,000 Min. Gauge Reading (cfs): 69.73 Min. Passby (cfs): 6.66

DEP Comments:

Source **Meathouse Fork @ Gagnon Withdrawal** Owner: **George L. Gagnon and Susan C. Gagnon**

Start Date: 5/10/2013 End Date: 5/10/2015 Total Volume (gal): Max. daily purchase (gal): Intake Latitude: 39.26054 Intake Longitude: -80.720998

Regulated Stream? Ref. Gauge ID: 3114500 MIDDLE ISLAND CREEK AT LITTLE, WV

Max. Pump rate (gpm): 1,000 Min. Gauge Reading (cfs): 71.96 Min. Passby (cfs): 13.10

DEP Comments:

Source **Meathouse Fork @ Whitehair Withdrawal** Owner: **Elton Whitehair**

Start Date: 5/10/2013 End Date: 5/10/2015 Total Volume (gal): Max. daily purchase (gal): Intake Latitude: 39.211317 Intake Longitude: -80.679592

Regulated Stream? Ref. Gauge ID: 3114500 MIDDLE ISLAND CREEK AT LITTLE, WV

Max. Pump rate (gpm): 1,000 Min. Gauge Reading (cfs): 69.73 Min. Passby (cfs): 7.28

DEP Comments:

● Source **Tom's Fork @ Erwin Withdrawal**

Owner: **John F. Erwin and Sandra E. Erwin**

Start Date	End Date	Total Volume (gal)	Max. daily purchase (gal)	Intake Latitude:	Intake Longitude:
5/10/2013	5/10/2015			39.174306	-80.702992

Regulated Stream? Ref. Gauge ID: 3114500 MIDDLE ISLAND CREEK AT LITTLE, WV

Max. Pump rate (gpm): **1,000** Min. Gauge Reading (cfs): **69.73** Min. Passby (cfs) **0.59**

DEP Comments:

● Source **Arnold Creek @ Davis Withdrawal**

Owner: **Jonathon Davis**

Start Date	End Date	Total Volume (gal)	Max. daily purchase (gal)	Intake Latitude:	Intake Longitude:
5/10/2013	5/10/2015			39.302006	-80.824561

Regulated Stream? Ref. Gauge ID: 3114500 MIDDLE ISLAND CREEK AT LITTLE, WV

Max. Pump rate (gpm): **1,000** Min. Gauge Reading (cfs): **69.73** Min. Passby (cfs) **3.08**

DEP Comments:

● Source **Buckeye Creek @ Powell Withdrawal**

Owner: **Dennis Powell**

Start Date	End Date	Total Volume (gal)	Max. daily purchase (gal)	Intake Latitude:	Intake Longitude:
5/10/2013	5/10/2015			39.277142	-80.690386

Regulated Stream? Ref. Gauge ID: 3114500 MIDDLE ISLAND CREEK AT LITTLE, WV

Max. Pump rate (gpm): **1,000** Min. Gauge Reading (cfs): **69.73** Min. Passby (cfs) **4.59**

DEP Comments:

Source **South Fork of Hughes River @ Knight Withdrawal**

Owner: **Tracy C. Knight & Stephanie C. Knight**

Start Date	End Date	Total Volume (gal)	Max. daily purchase (gal)	Intake Latitude:	Intake Longitude:
5/10/2013	5/10/2015			39.198369	-80.870969

Regulated Stream? Ref. Gauge ID: 3155220 SOUTH FORK HUGHES RIVER BELOW MACFARLAN, WA

Max. Pump rate (gpm): **3,000** Min. Gauge Reading (cfs): **39.80** Min. Passby (cfs) **1.95**

DEP Comments:

Source **North Fork of Hughes River @ Davis Withdrawal**

Owner: **Lewis P. Davis and Norma J. Davis**

Start Date	End Date	Total Volume (gal)	Max. daily purchase (gal)	Intake Latitude:	Intake Longitude:
5/10/2013	5/10/2015			39.322363	-80.936771

Regulated Stream? Ref. Gauge ID: 3155220 SOUTH FORK HUGHES RIVER BELOW MACFARLAN, WA

Max. Pump rate (gpm): **1,000** Min. Gauge Reading (cfs): **35.23** Min. Passby (cfs) **2.19**

DEP Comments:



### Source Summary

WMP: 01175

API Number:

017-FWC-00009

Operator:

Antero Resources

Pearl Jean North

### Purchased Water

● Source **Middle Island Creek @ Solo Construction** Owner: **Solo Construction, LLC**

Start Date	End Date	Total Volume (gal)	Max. daily purchase (gal)	Intake Latitude:	Intake Longitude:
5/10/2013	5/10/2015		1,000,000	39.399094	-81.185548

Regulated Stream? Ohio River Min. Flow Ref. Gauge ID: 9999999 Ohio River Station: Willow Island Lock & Dam

Max. Pump rate (gpm): Min. Gauge Reading (cfs): **6,468.00** Min. Passby (cfs)

DEP Comments: Elevation analysis indicates that this location has the same elevation as Middle Island Creek's pour point into the Ohio River. As such, it is deemed that water flow at this location is heavily influenced by the Ohio River.

● Source **Sun Valley Public Service District** Owner: **Sun Valley PSD**

Start Date	End Date	Total Volume (gal)	Max. daily purchase (gal)	Intake Latitude:	Intake Longitude:
5/10/2013	5/10/2015		200,000	-	-

Regulated Stream? Stonewall Jackson Dam Ref. Gauge ID: 3061000 WEST FORK RIVER AT ENTERPRISE, WV

Max. Pump rate (gpm): Min. Gauge Reading (cfs): **171.48** Min. Passby (cfs)

DEP Comments:

### Source Detail

V/MP- 01175

API/ID Number: 017-FWC-00009

Operator:

Antero Resources

Pearl Jean North

Source ID: 16065    Source Name: Middle Island Creek @ Solo Construction  
Solo Construction, LLC

Source Latitude: 39.399094  
Source Longitude: -81.185548

HUC-8 Code: 5030201

Drainage Area (sq. mi.): 25000    County: Pleasants

Anticipated withdrawal start date: 5/10/2013  
Anticipated withdrawal end date: 5/10/2015

- Endangered Species?     Mussel Stream?
- Trout Stream?             Tier 3?
- Regulated Stream?        Ohio River Min. Flow
- Proximate PSD?            City of St. Marys
- Gauged Stream?

Total Volume from Source (gal):

Max. Pump rate (gpm):

Max. Simultaneous Trucks:

Max. Truck pump rate (gpm)    0

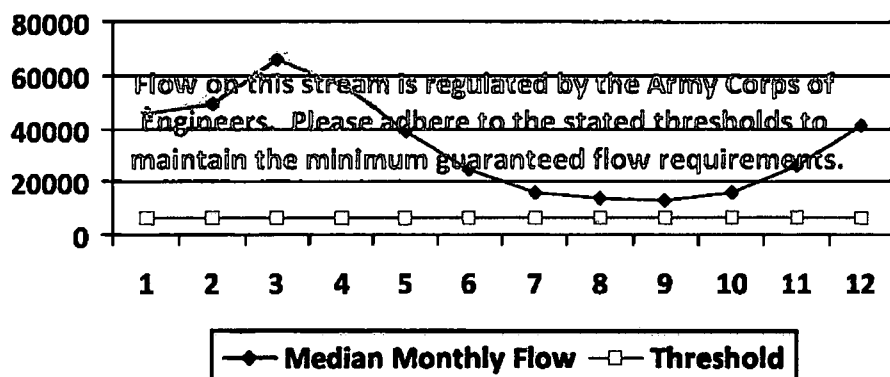
Reference Gaug    9999999    Ohio River Station: Willow Island Lock & Dam

Drainage Area (sq. mi.)    25,000.00

Gauge Threshold (cfs):    6468

Month	<u>Median monthly flow (cfs)</u>	<u>Threshold (+ pump)</u>	<u>Estimated Available water (cfs)</u>
1	45,700.00	-	-
2	49,200.00	-	-
3	65,700.00	-	-
4	56,100.00	-	-
5	38,700.00	-	-
6	24,300.00	-	-
7	16,000.00	-	-
8	13,400.00	-	-
9	12,800.00	-	-
10	15,500.00	-	-
11	26,300.00	-	-
12	41,300.00	-	-

### Water Availability Profile



### Water Availability Assessment of Location

Base Threshold (cfs): -

Upstream Demand (cfs): 0.00

Downstream Demand (cfs): 0.00

Pump rate (cfs):

Headwater Safety (cfs): 0.00

Ungauged Stream Safety (cfs): 0.00

---

Min. Gauge Reading (cfs): -

Passby at Location (cfs): -

"Threshold", as depicted in the chart above is meant only to indicate the calculated base threshold at the proposed withdrawal location. This value does not include the proposed pump rate or existing demand on the stream. Refer to the monthly breakdown above for a more complete estimation of water availability by month.

### Source Detail

WMP- 01175

API/ID Number: 017-FWC-00009

Operator:

Antero Resources

Pearl Jean North

Source ID: 16066    Source Name: Sun Valley Public Service District  
Sun Valley PSD

Source Latitude: -  
Source Longitude: -

HUC-8 Code: 5020002

Drainage Area (sq. mi.): 391.85    County: Harrison

Anticipated withdrawal start date: 5/10/2013

Anticipated withdrawal end date: 5/10/2015

- Endangered Species?     Mussel Stream?
- Trout Stream?             Tier 3?
- Regulated Stream?        Stonewall Jackson Dam
- Proximate PSD?
- Gauged Stream?

Total Volume from Source (gal):

Max. Pump rate (gpm):

Max. Simultaneous Trucks:

Max. Truck pump rate (gpm)

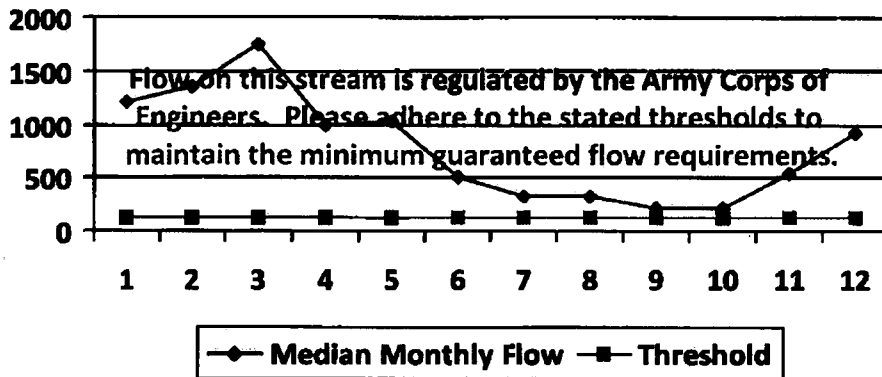
Reference Gaug    3061000    WEST FORK RIVER AT ENTERPRISE, WV

Drainage Area (sq. mi.)    759.00

Gauge Threshold (cfs):    234

Month	<u>Median monthly flow</u> (cfs)	<u>Threshold</u> (+ pump)	<u>Estimated Available</u> <u>water (cfs)</u>
1	1,200.75	-	-
2	1,351.92	-	-
3	1,741.33	-	-
4	995.89	-	-
5	1,022.23	-	-
6	512.21	-	-
7	331.86	-	-
8	316.87	-	-
9	220.48	-	-
10	216.17	-	-
11	542.45	-	-
12	926.12	-	-

### Water Availability Profile



### Water Availability Assessment of Location

Base Threshold (cfs): -

Upstream Demand (cfs): -

Downstream Demand (cfs): -

Pump rate (cfs): -

Headwater Safety (cfs): 0.00

Ungauged Stream Safety (cfs): 0.00

---

Min. Gauge Reading (cfs): -

Passby at Location (cfs): -

"Threshold", as depicted in the chart above is meant only to indicate the calculated base threshold at the proposed withdrawal location. This value does not include the proposed pump rate or existing demand on the stream. Refer to the monthly breakdown above for a more complete estimation of water availability by month.

### Source Detail

WRAP-01175

API/ID Number: 017-FWC-00009

Operator: Antero Resources

Pearl Jean North

Source ID: 16051    Source Name: Ohio River @ Ben's Run Withdrawal Site  
 Ben's Run Land Company Limited Partnership

Source Latitude: 39.46593  
 Source Longitude: -81.110781

HUC-8 Code: 5030201

Drainage Area (sq. mi.): 25000    County: Tyler

Anticipated withdrawal start date: 5/10/2013  
 Anticipated withdrawal end date: 5/10/2015

Total Volume from Source (gal):

- Endangered Species?     Mussel Stream?
- Trout Stream?     Tier 3?
- Regulated Stream?    Ohio River Min. Flow
- Proximate PSD?
- Gauged Stream?

Max. Pump rate (gpm): 3,360

Max. Simultaneous Trucks: 0

Max. Truck pump rate (gpm): 0

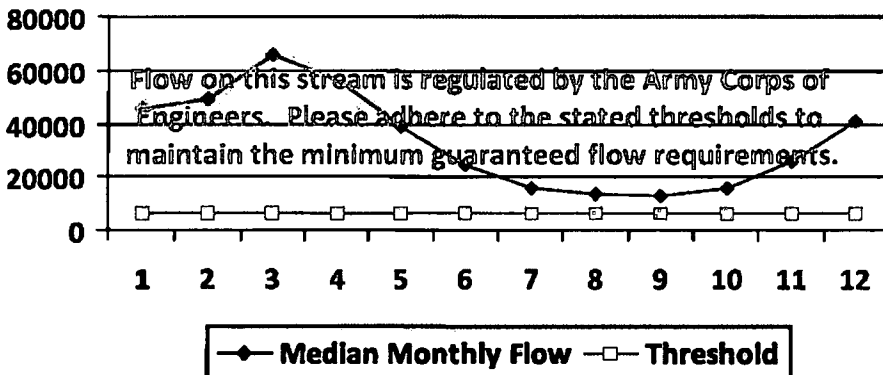
Reference Gaug: 9999999    Ohio River Station: Willow Island Lock & Dam

Drainage Area (sq. mi.): 25,000.00

Gauge Threshold (cfs): 6468

Month	Median monthly flow (cfs)	Threshold (+ pump)	Estimated Available water (cfs)
1	45,700.00	-	-
2	49,200.00	-	-
3	65,700.00	-	-
4	56,100.00	-	-
5	38,700.00	-	-
6	24,300.00	-	-
7	16,000.00	-	-
8	13,400.00	-	-
9	12,800.00	-	-
10	15,500.00	-	-
11	26,300.00	-	-
12	41,300.00	-	-

### Water Availability Profile



### Water Availability Assessment of Location

Base Threshold (cfs):	-
Upstream Demand (cfs):	0.00
Downstream Demand (cfs):	0.00
Pump rate (cfs):	7.49
Headwater Safety (cfs):	0.00
Ungauged Stream Safety (cfs):	0.00
Min. Gauge Reading (cfs):	-
Passby at Location (cfs):	-

"Threshold", as depicted in the chart above is meant only to indicate the calculated base threshold at the proposed withdrawal location. This value does not include the proposed pump rate or existing demand on the stream. Refer to the monthly breakdown above for a more complete estimation of water availability by month.

**Source Detail**

WMP- 01175

API/ID Number: 017-FWC-00009

Operator:

Antero Resources

Pearl Jean North

Source ID: 16052    Source Name: West Fork River @ JCP Withdrawal  
James & Brenda Raines

Source Latitude: 39.320913

Source Longitude: -80.337572

HUC-8 Code: 5020002

Drainage Area (sq. mi.): 532.2    County: Harrison

Anticipated withdrawal start date: 5/10/2013

Anticipated withdrawal end date: 5/10/2015

- Endangered Species?     Mussel Stream?
- Trout Stream?             Tier 3?
- Regulated Stream?        Stonewall Jackson Dam
- Proximate PSD?
- Gauged Stream?

Total Volume from Source (gal):

Max. Pump rate (gpm): 2,000

Max. Simultaneous Trucks: 0

Max. Truck pump rate (gpm) 0

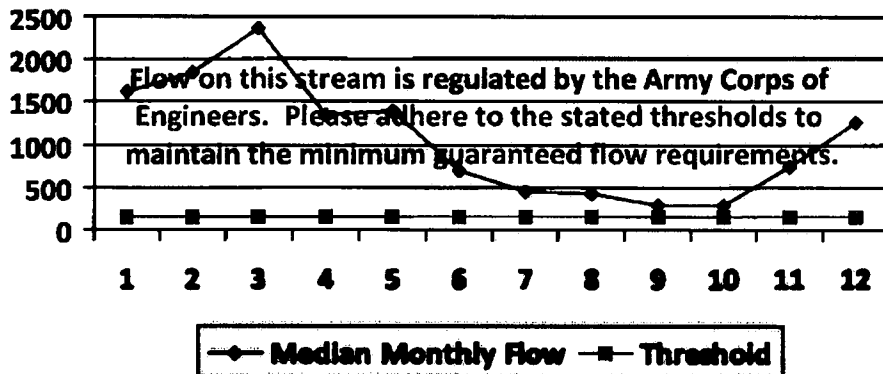
Reference Gaug 3061000 WEST FORK RIVER AT ENTERPRISE, WV

Drainage Area (sq. mi.) 759.00

Gauge Threshold (cfs): 234

Month	Median monthly flow (cfs)	Threshold (+ pump)	Estimated Available water (cfs)
1	1,630.82	+	+
2	1,836.14	-	-
3	2,365.03	-	-
4	1,352.59	.	.
5	1,388.37	-	-
6	695.67	-	-
7	450.73	-	-
8	430.37	-	-
9	299.45	-	-
10	293.59	-	-
11	736.74	-	-
12	1,257.84	-	-

**Water Availability Profile**



**Water Availability Assessment of Location**

Base Threshold (cfs):	-
Upstream Demand (cfs):	24.29
Downstream Demand (cfs):	0.00
Pump rate (cfs):	4.46
Headwater Safety (cfs):	0.00
Ungauged Stream Safety (cfs):	0.00
Min. Gauge Reading (cfs):	-
Passby at Location (cfs):	-

"Threshold", as depicted in the chart above is meant only to indicate the calculated base threshold at the proposed withdrawal location. This value does not include the proposed pump rate or existing demand on the stream. Refer to the monthly breakdown above for a more complete estimation of water availability by month.

### Source Detail

WMP- 01175

API/ID Number: 017-FWC-00009

Operator:

Antero Resources

Pearl Jean North

Source ID: 16053    Source Name: West Fork River @ McDonald Withdrawal  
David Shrieves

Source Latitude: 39.16761  
Source Longitude: -80.45069

HUC-8 Code: 5020002

Drainage Area (sq. mi.): 314.91    County: Harrison

Anticipated withdrawal start date: 5/10/2013

Anticipated withdrawal end date: 5/10/2015

- Endangered Species?     Mussel Stream?
- Trout Stream?     Tier 3?
- Regulated Stream?    Stonewall Jackson Dam
- Proximate PSD?
- Gauged Stream?

Total Volume from Source (gal):

Max. Pump rate (gpm): 3,000

Max. Simultaneous Trucks: 0

Max. Truck pump rate (gpm): 0

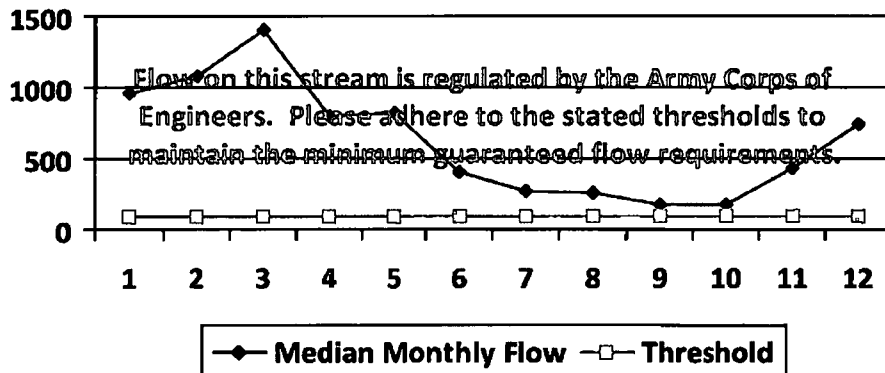
Reference Gaug: 3061000    WEST FORK RIVER AT ENTERPRISE, WV

Drainage Area (sq. mi.): 759.00

Gauge Threshold (cfs): 234

Month	Median monthly flow (cfs)	Threshold (+ pump)	Estimated Available water (cfs)
1	964.98	-	-
2	1,086.47	-	-
3	1,399.42	-	-
4	800.34	-	-
5	821.52	-	-
6	411.64	-	-
7	266.70	-	-
8	254.66	-	-
9	177.19	-	-
10	172.72	-	-
11	435.94	-	-
12	744.28	-	-

### Water Availability Profile



### Water Availability Assessment of Location

Base Threshold (cfs):	-
Upstream Demand (cfs):	24.29
Downstream Demand (cfs):	0.00
Pump rate (cfs):	6.68
Headwater Safety (cfs):	24.27
Ungauged Stream Safety (cfs):	0.00
<hr/>	
Min. Gauge Reading (cfs):	-
Passby at Location (cfs):	-

"Threshold", as depicted in the chart above is meant only to indicate the calculated base threshold at the proposed withdrawal location. This value does not include the proposed pump rate or existing demand on the stream. Refer to the monthly breakdown above for a more complete estimation of water availability by month.

### Source Detail

WMP-01175

API/ID Number: 017-FWC-00009

Operator:

Antero Resources

Pearl Jean North

Source ID: 16054    Source Name: West Fork River @ GAL Withdrawal  
David Shrieves

Source Latitude: 39.16422  
Source Longitude: -80.45173

HUC-8 Code: 5020002

Drainage Area (sq. mi.): 313.67    County: Harrison

Anticipated withdrawal start date: 5/10/2013

Anticipated withdrawal end date: 5/10/2015

- Endangered Species?     Mussel Stream?
- Trout Stream?             Tier 3?
- Regulated Stream?        Stonewall Jackson Dam
- Proximate PSD?
- Gauged Stream?

Total Volume from Source (gal):

Max. Pump rate (gpm): 2,000

Max. Simultaneous Trucks: 0

Max. Truck pump rate (gpm): 0

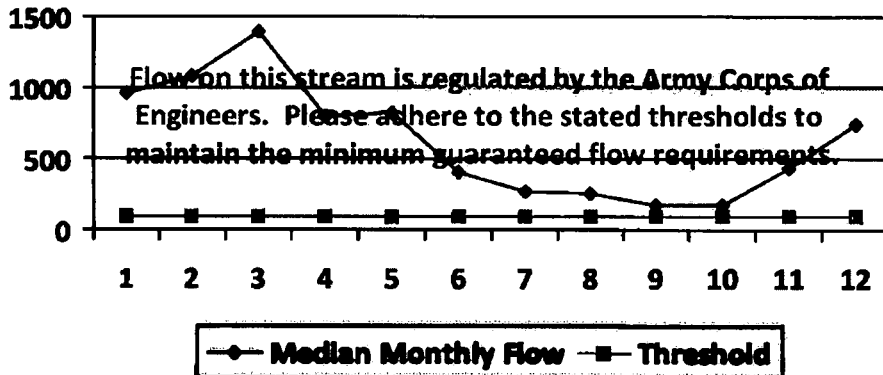
Reference Gaug    3061000    WEST FORK RIVER AT ENTERPRISE, WV

Drainage Area (sq. mi.)    759.00

Gauge Threshold (cfs): 234

Month	<u>Median monthly flow</u> (cfs)	<u>Threshold</u> (+ pump)	<u>Estimated Available</u> <u>water</u> (cfs)
1	961.18	-	-
2	1,082.19	-	-
3	1,393.91	-	-
4	797.19	-	-
5	818.28	-	-
6	410.02	-	-
7	265.65	-	-
8	253.65	-	-
9	176.49	-	-
10	173.04	-	-
11	434.22	-	-
12	741.35	-	-

### Water Availability Profile



### Water Availability Assessment of Location

Base Threshold (cfs):	-
Upstream Demand (cfs):	24.29
Downstream Demand (cfs):	0.00
Pump rate (cfs):	4.46
Headwater Safety (cfs):	24.18
Ungauged Stream Safety (cfs):	0.00
<hr/>	
Min. Gauge Reading (cfs):	-
Passby at Location (cfs):	-

"Threshold", as depicted in the chart above is meant only to indicate the calculated base threshold at the proposed withdrawal location. This value does not include the proposed pump rate or existing demand on the stream. Refer to the monthly breakdown above for a more complete estimation of water availability by month.

**Source Detail**

WMP-01175

API/ID Number: 017-FWC-00009

Operator:

Antero Resources

Pearl Jean North

Source ID: 16055    Source Name: Middle Island Creek @ Dawson Withdrawal  
Gary D. and Rella A. Dawson

Source Latitude: 39.379292  
Source Longitude: -80.867803

HUC-8 Code: 5030201

Drainage Area (sq. mi.): 181.34    County: Tyler

Anticipated withdrawal start date: 5/10/2013  
Anticipated withdrawal end date: 5/10/2015

- Endangered Species?     Mussel Stream?
- Trout Stream?             Tier 3?
- Regulated Stream?
- Proximate PSD?
- Gauged Stream?

Total Volume from Source (gal):

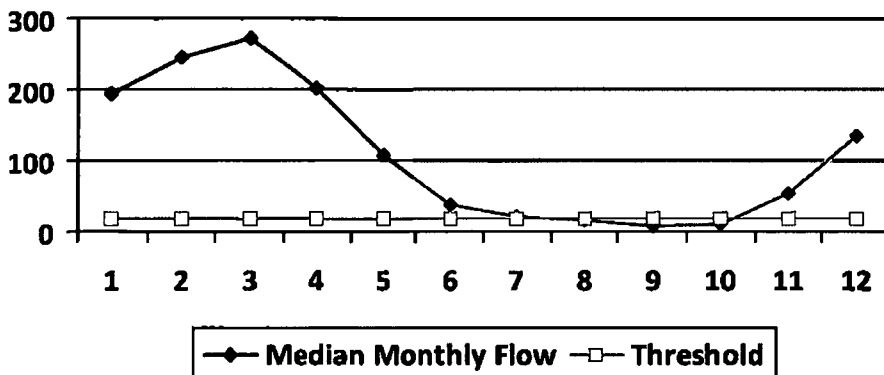
Max. Pump rate (gpm): 3,000  
Max. Simultaneous Trucks: 0  
Max. Truck pump rate (gpm): 0

Reference Gaug: 3114500    MIDDLE ISLAND CREEK AT LITTLE, WV

Drainage Area (sq. mi.): 458.00    Gauge Threshold (cfs): 45

Month	Median monthly flow (cfs)	Threshold (+ pump)	Estimated Available water (cfs)
1	194.47	42.06	152.68
2	244.62	42.06	202.83
3	273.72	42.06	231.93
4	203.26	42.06	161.47
5	107.22	42.06	65.43
6	37.44	42.06	-4.35
7	21.19	42.06	-20.60
8	17.45	42.06	-24.34
9	8.94	42.06	-32.85
10	11.23	42.06	-30.56
11	54.82	42.06	13.04
12	133.96	42.06	92.17

**Water Availability Profile**



**Water Availability Assessment of Location**

Base Threshold (cfs): 17.82  
 Upstream Demand (cfs): 13.10  
 Downstream Demand (cfs): 6.55  
 Pump rate (cfs): 6.68  
 Headwater Safety (cfs): 4.45  
 Ungauged Stream Safety (cfs): 0.00

---

Min. Gauge Reading (cfs): 76.03  
 Passby at Location (cfs): 28.82

"Threshold", as depicted in the chart above is meant only to indicate the calculated base threshold at the proposed withdrawal location. This value does not include the proposed pump rate or existing demand on the stream. Refer to the monthly breakdown above for a more complete estimation of water availability by month.



**Source Detail**

WMP- 01175

API/ID Number: 017-FWC-00009

Operator:

Antero Resources

Pearl Jean North

Source ID: 16056    Source Name: McElroy Creek @ Forest Withdrawal  
Forest C. & Brenda L. Moore

Source Latitude: 39.39675  
Source Longitude: -80.738197

HUC-8 Code: 5030201

Drainage Area (sq. mi.): 88.85    County: Tyler

Anticipated withdrawal start date: 5/10/2013

Anticipated withdrawal end date: 5/10/2015

- Endangered Species?     Mussel Stream?
- Trout Stream?             Tier 3?
- Regulated Stream?
- Proximate PSD?
- Gauged Stream?

Total Volume from Source (gal):

Max. Pump rate (gpm): 1,000

Max. Simultaneous Trucks: 0

Max. Truck pump rate (gpm): 0

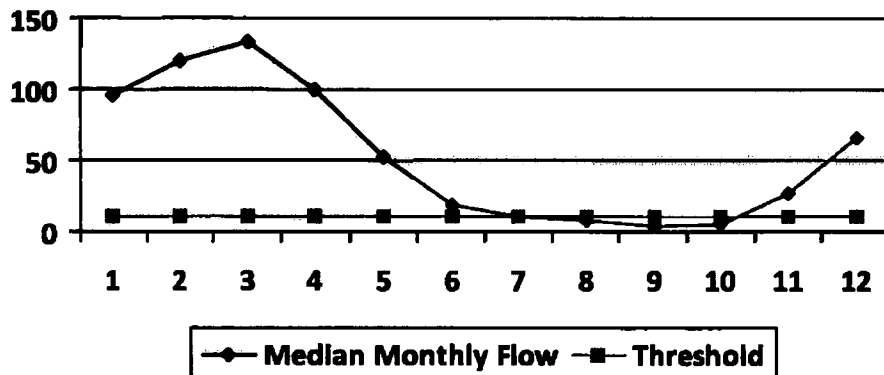
Reference Gaug: 3114500    MIDDLE ISLAND CREEK AT LITTLE, WV

Drainage Area (sq. mi.): 458.00

Gauge Threshold (cfs): 45

Month	Median monthly flow (cfs)	Threshold (+ pump)	Estimated Available water (cfs)
1	95.28	19.78	75.68
2	119.86	19.78	100.25
3	134.11	19.78	114.51
4	99.59	19.78	79.99
5	52.54	19.78	32.93
6	18.35	19.78	-1.26
7	10.38	19.78	-9.22
8	8.55	19.78	-11.05
9	4.38	19.78	-15.23
10	5.50	19.78	-14.10
11	26.86	19.78	7.26
12	65.63	19.78	46.03

**Water Availability Profile**



**Water Availability Assessment of Location**

Base Threshold (cfs):	8.73
Upstream Demand (cfs):	4.46
Downstream Demand (cfs):	0.00
Pump rate (cfs):	2.23
Headwater Safety (cfs):	2.18
Ungauged Stream Safety (cfs):	2.18
Min. Gauge Reading (cfs):	<b>74.19</b>
Passby at Location (cfs):	<b>13.09</b>

"Threshold", as depicted in the chart above is meant only to indicate the calculated base threshold at the proposed withdrawal location. This value does not include the proposed pump rate or existing demand on the stream. Refer to the monthly breakdown above for a more complete estimation of water availability by month.

### Source Detail

WMP- 01175

API/ID Number: 017-FWC-00009

Operator:

Antero Resources

Pearl Jean North

Source ID: 16057    Source Name: McElroy Creek @ Sweeney Withdrawal  
Bill Sweeney

Source Latitude: 39.398123  
Source Longitude: -80.656808

HUC-8 Code: 5030201

Drainage Area (sq. mi.): 45.16    County: Doddridge

Anticipated withdrawal start date: 5/10/2013

Anticipated withdrawal end date: 5/10/2015

Endangered Species?     Mussel Stream?

Trout Stream?     Tier 3?

Total Volume from Source (gal):

Regulated Stream?

Max. Pump rate (gpm): 1,000

Proximate PSD?

Max. Simultaneous Trucks: 0

Gauged Stream?

Max. Truck pump rate (gpm): 0

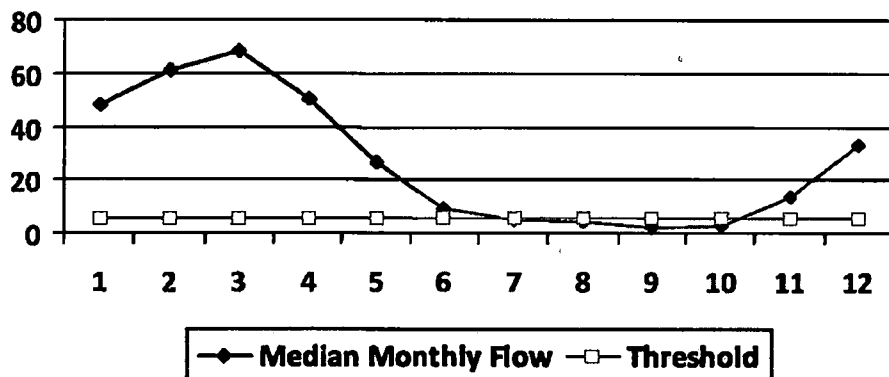
Reference Gaug: 3114500    MIDDLE ISLAND CREEK AT LITTLE, WV

Drainage Area (sq. ml.): 458.00

Gauge Threshold (cfs): 45

Month	Median monthly flow (cfs)	Threshold (+ pump)	Estimated Available water (cfs)
1	48.43	8.88	39.93
2	60.92	8.88	52.42
3	68.17	8.88	59.67
4	50.62	8.88	42.12
5	26.70	8.88	18.21
6	9.32	8.88	0.83
7	5.28	8.88	-3.22
8	4.34	8.88	-4.15
9	2.23	8.88	-6.27
10	2.80	8.88	-5.70
11	13.65	8.88	5.16
12	33.36	8.88	24.86

### Water Availability Profile



### Water Availability Assessment of Location

Base Threshold (cfs):	4.44
Upstream Demand (cfs):	0.00
Downstream Demand (cfs):	0.00
Pump rate (cfs):	2.23
Headwater Safety (cfs):	1.11
Ungauged Stream Safety (cfs):	1.11
Min. Gauge Reading (cfs):	69.73
Passby at Location (cfs):	6.66

"Threshold", as depicted in the chart above is meant only to indicate the calculated base threshold at the proposed withdrawal location. This value does not include the proposed pump rate or existing demand on the stream. Refer to the monthly breakdown above for a more complete estimation of water availability by month.

### Source Detail

WMP- 01175

API/ID Number: 017-FWC-00009

Operator: Antero Resources

Pearl Jean North

Source ID: 16058    Source Name: Meathouse Fork @ Gagnon Withdrawal  
George L. Gagnon and Susan C. Gagnon

Source Latitude: 39.26054  
Source Longitude: -80.720998

HUC-8 Code: 5030201

Drainage Area (sq. mi.): 60.6    County: Doddridge

Anticipated withdrawal start date: 5/10/2013

Anticipated withdrawal end date: 5/10/2015

Total Volume from Source (gal):

Max. Pump rate (gpm): 1,000

Max. Simultaneous Trucks: 0

Max. Truck pump rate (gpm): 0

- Endangered Species?     Mussel Stream?
- Trout Stream?             Tier 3?
- Regulated Stream?
- Proximate PSD?
- Gauged Stream?

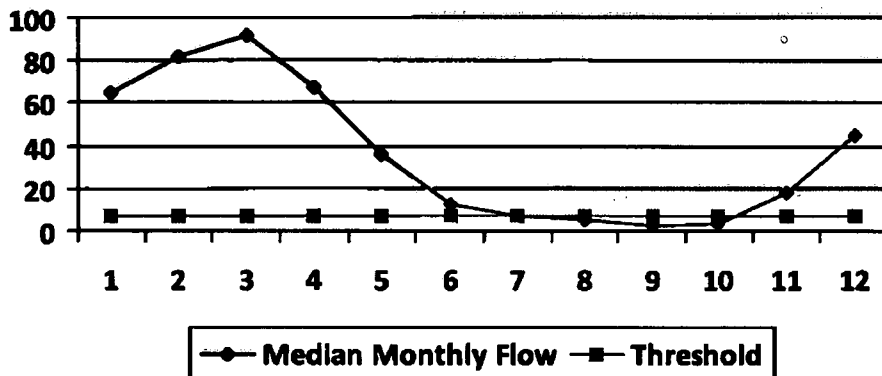
Reference Gaug    3114500    MIDDLE ISLAND CREEK AT LITTLE, WV

Drainage Area (sq. mi.)    458.00

Gauge Threshold (cfs): 45

Month	<u>Median monthly flow</u> (cfs)	<u>Threshold</u> (+ pump)	<u>Estimated Available</u> water (cfs)
1	64.99	13.39	51.70
2	81.75	13.39	68.46
3	91.47	13.39	78.19
4	67.93	13.39	54.64
5	35.83	13.39	22.55
6	12.51	13.39	-0.77
7	7.08	13.39	-6.20
8	5.83	13.39	-7.45
9	2.99	13.39	-10.30
10	3.75	13.39	-9.53
11	18.32	13.39	5.04
12	44.76	13.39	31.48

### Water Availability Profile



### Water Availability Assessment of Location

Base Threshold (cfs):	5.95
Upstream Demand (cfs):	2.23
Downstream Demand (cfs):	2.81
Pump rate (cfs):	2.23
Headwater Safety (cfs):	1.49
Ungauged Stream Safety (cfs):	1.49
<hr/>	
Mfn. Gauge Reading (cfs):	<b>71.96</b>
Passby at Location (cfs):	<b>11.74</b>

"Threshold", as depicted in the chart above is meant only to indicate the calculated base threshold at the proposed withdrawal location. This value does not include the proposed pump rate or existing demand on the stream. Refer to the monthly breakdown above for a more complete estimation of water availability by month.

### Source Detail

WMP-01175

AFI/ID Number: 017-FWC-00009

Operator:

Antero Resources

Pearl Jean North

Source ID: 16059    Source Name: Meathouse Fork @ Whitehair Withdrawal  
Elton Whitehair

Source Latitude: 39.211317

Source Longitude: -80.679592

HUC-8 Code: 5030201

Drainage Area (sq. mi.): 30.37    County: Doddridge

Anticipated withdrawal start date: 5/10/2013

Anticipated withdrawal end date: 5/10/2015

- Endangered Species?     Mussel Stream?
- Trout Stream?     Tier 3?
- Regulated Stream?
- Proximate PSD?
- Gauged Stream?

Total Volume from Source (gal):

Max. Pump rate (gpm): 1,000

Max. Simultaneous Trucks: 0

Max. Truck pump rate (gpm): 0

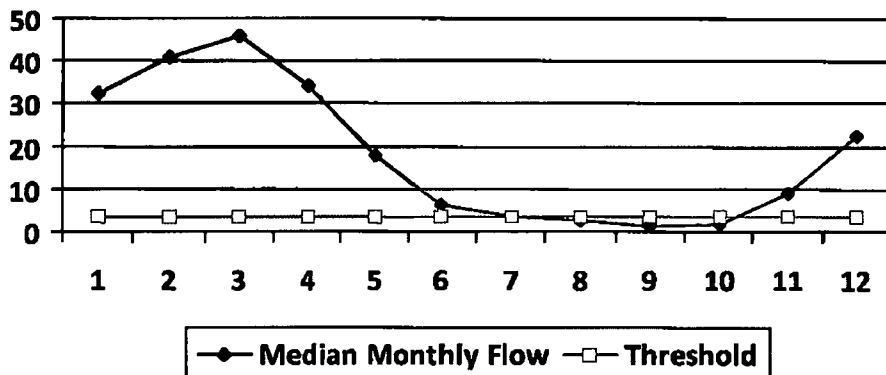
Reference Gaug: 3114500    MIDDLE ISLAND CREEK AT LITTLE, WV

Drainage Area (sq. mi.): 458.00

Gauge Threshold (cfs): 45

Month	<u>Median monthly flow (cfs)</u>	<u>Threshold (+ pump)</u>	<u>Estimated Available water (cfs)</u>
1	32.57	6.70	26.15
2	40.97	6.70	34.55
3	45.84	6.70	39.42
4	34.04	6.70	27.62
5	17.96	6.70	11.54
6	6.27	6.70	-0.15
7	3.55	6.70	-2.87
8	2.92	6.70	-3.50
9	1.50	6.70	-4.92
10	1.88	6.70	-4.54
11	9.18	6.70	2.76
12	22.43	6.70	16.01

### Water Availability Profile



### Water Availability Assessment of Location

Base Threshold (cfs):	2.98
Upstream Demand (cfs):	0.00
Downstream Demand (cfs):	2.81
Pump rate (cfs):	2.23
Headwater Safety (cfs):	0.75
Ungauged Stream Safety (cfs):	0.75
<hr/>	
Min. Gauge Reading (cfs):	<b>69.73</b>
Passby at Location (cfs):	<b>7.29</b>

"Threshold", as depicted in the chart above is meant only to indicate the calculated base threshold at the proposed withdrawal location. This value does not include the proposed pump rate or existing demand on the stream. Refer to the monthly breakdown above for a more complete estimation of water availability by month.

### Source Detail

WMP- 01175

API/iD Number: 017-FWC-00009

Operator:

Antero Resources

Pearl Jean North

Source ID: 16060    Source Name Tom's Fork @ Erwin Withdrawal  
John F. Erwin and Sandra E. Erwin

Source Latitude: 39.174306

Source Longitude: -80.702992

HUC-8 Code: 5030201

Drainage Area (sq. mi.): 4.01    County: Doddridge

Anticipated withdrawal start date: 5/10/2013

Anticipated withdrawal end date: 5/10/2015

Total Volume from Source (gal):

Max. Pump rate (gpm): 1,000

Max. Simultaneous Trucks: 0

Max. Truck pump rate (gpm) 0

- Endangered Species?     Mussel Stream?
- Trout Stream?             Tier 3?
- Regulated Stream?
- Proximate PSD?
- Gauged Stream?

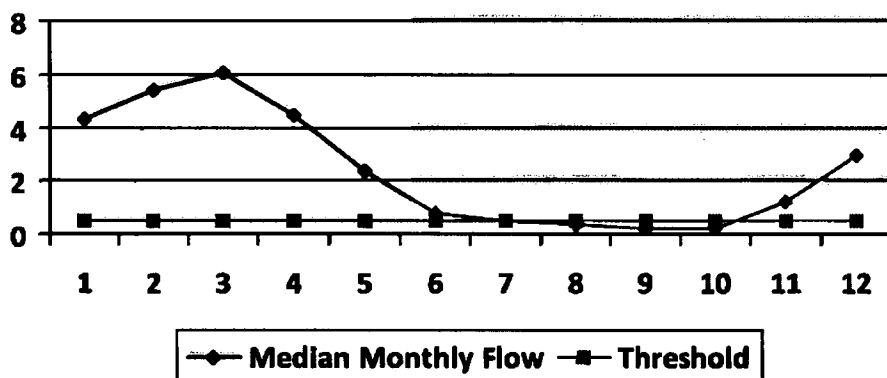
Reference Gaug 3114500    MIDDLE ISLAND CREEK AT LITTLE, WV

Drainage Area (sq. mi.) 458.00

Gauge Threshold (cfs): 45

Month	<u>Median monthly flow</u> (cfs)	<u>Threshold</u> (+ pump)	<u>Estimated Available</u> water (cfs)
1	4.30	2.82	1.88
2	5.41	2.82	2.98
3	6.05	2.82	3.63
4	4.49	2.82	2.07
5	2.37	2.82	-0.05
6	0.83	2.82	-1.60
7	0.47	2.82	-1.96
8	0.39	2.82	-2.04
9	0.20	2.82	-2.23
10	0.25	2.82	-2.18
11	1.21	2.82	-1.21
12	2.96	2.82	0.54

### Water Availability Profile



### Water Availability Assessment of Location

Base Threshold (cfs):	0.39
Upstream Demand (cfs):	0.00
Downstream Demand (cfs):	0.00
Pump rate (cfs):	2.23
Headwater Safety (cfs):	0.10
Ungauged Stream Safety (cfs):	0.10
<hr/>	
Min. Gauge Reading (cfs):	69.73
Passby at Location (cfs):	0.59

"Threshold", as depicted in the chart above is meant only to indicate the calculated base threshold at the proposed withdrawal location. This value does not include the proposed pump rate or existing demand on the stream. Refer to the monthly breakdown above for a more complete estimation of water availability by month.

### Source Detail

WMP- 01175

AP#/ID Number: 017-FWC-00009

Operator:

Antero Resources

Pearl Jean North

Source ID: 16061    Source Name: Arnold Creek @ Davis Withdrawal  
Jonathon Davis

Source Latitude: 39.302006

Source Longitude: -80.824561

HUC-8 Code: 5030201

Drainage Area (sq. mi.): 20.83    County: Doddridge

Anticipated withdrawal start date: 5/10/2013

Anticipated withdrawal end date: 5/10/2015

- Endangered Species?     Mussel Stream?
- Trout Stream?     Tier 3?
- Regulated Stream?
- Proximate PSD?
- Gauged Stream?

Total Volume from Source (gal):

Max. Pump rate (gpm): 1,000

Max. Simultaneous Trucks: 0

Max. Truck pump rate (gpm): 0

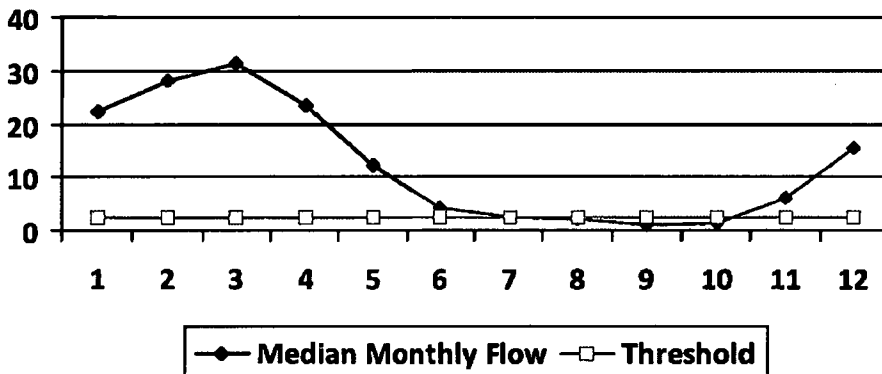
Reference Gaug: 3114500    MIDDLE ISLAND CREEK AT LITTLE, WV

Drainage Area (sq. mi.): 458.00

Gauge Threshold (cfs): 45

Month	<u>Median monthly flow (cfs)</u>	<u>Threshold (+ pump)</u>	<u>Estimated Available water (cfs)</u>
1	22.34	5.30	17.29
2	28.10	5.30	23.05
3	31.44	5.30	26.39
4	23.35	5.30	18.30
5	12.32	5.30	7.26
6	4.30	5.30	-0.75
7	2.43	5.30	-2.62
8	2.00	5.30	-3.05
9	1.03	5.30	-4.03
10	1.29	5.30	-3.76
11	6.30	5.30	1.25
12	15.39	5.30	10.34

### Water Availability Profile



### Water Availability Assessment of Location

Base Threshold (cfs):	2.05
Upstream Demand (cfs):	0.00
Downstream Demand (cfs):	0.00
Pump rate (cfs):	2.23
Headwater Safety (cfs):	0.51
Ungauged Stream Safety (cfs):	0.51
<hr/>	
Min. Gauge Reading (cfs):	69.73
Passby at Location (cfs):	3.07

"Threshold", as depicted in the chart above is meant only to indicate the calculated base threshold at the proposed withdrawal location. This value does not include the proposed pump rate or existing demand on the stream. Refer to the monthly breakdown above for a more complete estimation of water availability by month.

### Source Detail

WMP-01175

API/ID Number: 017-FWC-00009

Operator:

Antero Resources

Pearl Jean North

Source ID: 16062    Source Name: Buckeye Creek @ Powell Withdrawal  
Dennis Powell

Source Latitude: 39.277142  
Source Longitude: -80.690386

HUC-8 Code: 5030201

Drainage Area (sq. mi.): 31.15    County: Doddridge

Anticipated withdrawal start date: 5/10/2013

Anticipated withdrawal end date: 5/10/2015

- Endangered Species?     Mussel Stream?
- Trout Stream?             Tier 3?
- Regulated Stream?
- Proximate PSD?
- Gauged Stream?

Total Volume from Source (gal):

Max. Pump rate (gpm): 1,000

Max. Simultaneous Truck: 0

Max. Truck pump rate (gpm): 0

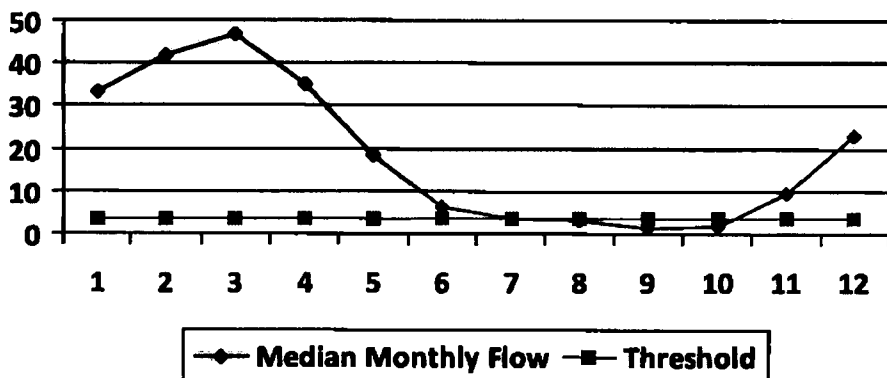
Reference Gaug: 3114500    MIDDLE ISLAND CREEK AT LITTLE, WV

Drainage Area (sq. mi.): 458.00

Gauge Threshold (cfs): 45

Month	<u>Median monthly flow</u> (cfs)	<u>Threshold</u> <u>(+ pump)</u>	<u>Estimated Available</u> <u>water (cfs)</u>
1	33.41	6.82	26.95
2	42.02	6.82	35.56
3	47.02	6.82	40.56
4	34.92	6.82	28.46
5	18.42	6.82	11.96
6	6.43	6.82	-0.03
7	3.64	6.82	-2.82
8	3.00	6.82	-3.46
9	1.53	6.82	-4.92
10	1.93	6.82	-4.53
11	9.42	6.82	2.96
12	23.01	6.82	16.55

### Water Availability Profile



### Water Availability Assessment of Location

Base Threshold (cfs):	3.06
Upstream Demand (cfs):	0.00
Downstream Demand (cfs):	0.00
Pump rate (cfs):	2.23
Headwater Safety (cfs):	0.77
Ungauged Stream Safety (cfs):	0.77
<hr/>	
Mln. Gauge Reading (cfs):	69.73
Passby at Location (cfs):	4.59

"Threshold", as depicted in the chart above is meant only to indicate the calculated base threshold at the proposed withdrawal location. This value does not include the proposed pump rate or existing demand on the stream. Refer to the monthly breakdown above for a more complete estimation of water availability by month.

### Source Detail

WMP 01175

API/ID Number: 017-FWC-00009

Operator:

Antero Resources

Pearl Jean North

Source ID: 16063    Source Name: South Fork of Hughes River @ Knight Withdrawal  
 Tracy C. Knight & Stephanie C. Knight

Source Latitude: 39.198369  
 Source Longitude: -80.870969

HUC-8 Code: 5030203

Drainage Area (sq. mi.): 16.26    County: Ritchie

Anticipated withdrawal start date: 5/10/2013

Anticipated withdrawal end date: 5/10/2015

Endangered Species?     Mussel Stream?

Trout Stream?     Tier 3?

Regulated Stream?

Proximate PSD?

Gauged Stream?

Total Volume from Source (gal):

Max. Pump rate (gpm): 3,000

Max. Simultaneous Trucks: 0

Max. Truck pump rate (gpm): 0

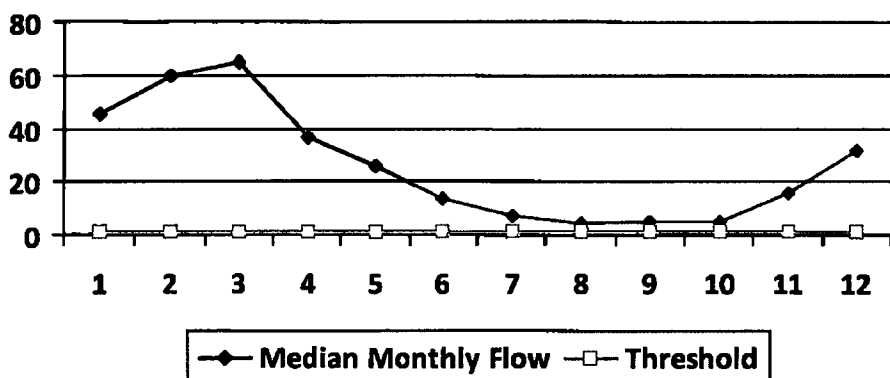
Reference Gaug: 3155220    SOUTH FORK HUGHES RIVER BELOW MACFARLAN, WV

Drainage Area (sq. mi.): 229.00

Gauge Threshold (cfs): 22

Month	Median monthly flow (cfs)	Threshold (+ pump)	Estimated Available water (cfs)
1	45.67	14.26	31.44
2	59.55	14.26	45.31
3	65.21	14.26	50.97
4	36.87	14.26	22.63
5	25.86	14.26	11.63
6	13.90	14.26	-0.33
7	6.89	14.26	-7.34
8	3.98	14.26	-10.25
9	4.79	14.26	-9.45
10	5.20	14.26	-9.04
11	15.54	14.26	1.30
12	32.06	14.26	17.82

### Water Availability Profile



### Water Availability Assessment of Location

Base Threshold (cfs):	1.56
Upstream Demand (cfs):	5.62
Downstream Demand (cfs):	0.00
Pump rate (cfs):	6.68
Headwater Safety (cfs):	0.39
Ungauged Stream Safety (cfs):	0.00
Min. Gauge Reading (cfs):	39.80
Passby at Location (cfs):	1.95

"Threshold", as depicted in the chart above is meant only to indicate the calculated base threshold at the proposed withdrawal location. This value does not include the proposed pump rate or existing demand on the stream. Refer to the monthly breakdown above for a more complete estimation of water availability by month.



**Source Detail**

WMP-01175

API/ID Number: 017-FWC-00009

Operator:

Antero Resources

Pearl Jean North

Source ID: 16064    Source Name: North Fork of Hughes River @ Davis Withdrawal  
Lewis P. Davis and Norma J. Davis

Source Latitude: 39.322363  
Source Longitude: -80.936771

HUC-8 Code: 5030203

Drainage Area (sq. mi.): 15.18    County: Ritchie

Anticipated withdrawal start date: 5/10/2013

Anticipated withdrawal end date: 5/10/2015

- Endangered Species?     Mussel Stream?
- Trout Stream?             Tier 3?
- Regulated Stream?
- Proximate PSD?
- Gauged Stream?

Total Volume from Source (gal):

Max. Pump rate (gpm): 1,000

Max. Simultaneous Trucks: 0

Max. Truck pump rate (gpm): 0

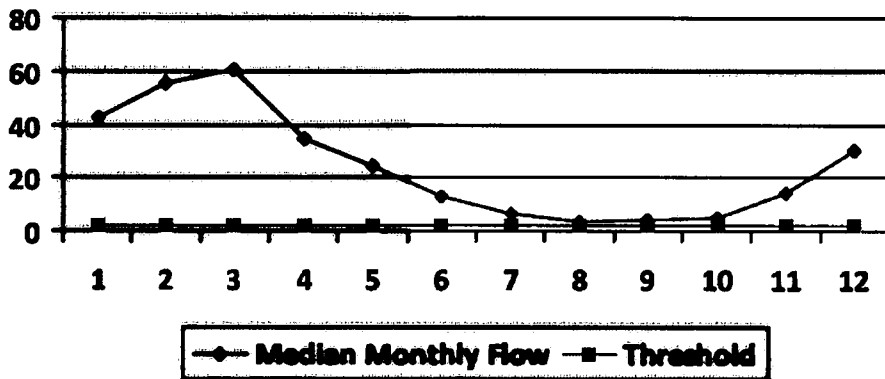
Reference Gaug: 3155220    SOUTH FORK HUGHES RIVER BELOW MACFARLAN, WV

Drainage Area (sq. mi.): 229.00

Gauge Threshold (cfs): 22

Month	Median monthly flow (cfs)	Threshold (+ pump)	Estimated Available water (cfs)
1	42.64	4.42	38.36
2	<b>55.59</b>	4.42	51.32
3	60.88	4.42	56.60
4	<b>34.42</b>	4.42	30.14
5	24.15	4.42	19.87
6	<b>12.98</b>	4.42	8.70
7	6.44	4.42	2.16
8	<b>3.72</b>	4.42	-0.56
9	4.47	4.42	0.19
10	4.85	4.42	0.57
11	14.50	4.42	10.23
12	29.93	4.42	25.65

**Water Availability Profile**



**Water Availability Assessment of Location**

Base Threshold (cfs):	1.46
Upstream Demand (cfs):	0.00
Downstream Demand (cfs):	0.00
Pump rate (cfs):	2.23
Headwater Safety (cfs):	0.36
Ungauged Stream Safety (cfs):	0.36
<b>Min. Gauge Reading (cfs):</b>	<b>35.23</b>
<b>Passby at Location (cfs):</b>	<b>2.19</b>

"Threshold", as depicted in the chart above is meant only to indicate the calculated base threshold at the proposed withdrawal location. This value does not include the proposed pump rate or existing demand on the stream. Refer to the monthly breakdown above for a more complete estimation of water availability by month.

# west virginia department of environmental protection



## Water Management Plan: Secondary Water Sources



WMP-01175

API/ID Number 017-FWC-00009

Operator:

Antero Resources

Pearl Jean North

### Important:

For each proposed secondary water source identified in your water management plan (i.e., groundwater well, lake/reservoir, recycled frac water, multi-site impoundment, out-of-state source), DEP makes no estimation of the availability of water. These sources may prove to be unsuitable water supplies. Please review the following notes:

- For groundwater supply wells, DEP recommends that the operator contact the local health department prior to drilling any new well; and reminds the operator that all drinking water wells within 1,500 feet of a water supply well shall be flow- and quality-tested by the operator at the request of the drinking well owner prior to operation of the water supply well.
- For each proposed multi-site impoundment water source identified in your water management plan (if applicable), DEP will review the withdrawal limits established in the referenced Water Management Plan for current suitability and provide to the operator these limits for each identified intake. Note that withdrawal limits may be modified as necessary based on changing demands upon that water supply.

### Lake/Reservoir

Source ID: 16067	Source Name	City of Salem Reservoir (Lower Dog Run)	Source start date:	5/10/2013	
		Public Water Provider	Source end date:	5/10/2015	
Source Lat:	39.28834	Source Long:	-80.54966	County	Harrison
Max. Daily Purchase (gal)	1,000,000	Total Volume from Source (gal):			

DEP Comments:

## Pearl Jean North

**Important:**

For each proposed secondary water source identified in your water management plan (i.e., groundwater well, lake/reservoir, recycled frac water, multi-site impoundment, out-of-state source), DEP makes no estimation of the availability of water. These sources may prove to be unsuitable water supplies. Please review the following notes:

- For groundwater supply wells, DEP recommends that the operator contact the local health department prior to drilling any new well; and reminds the operator that all drinking water wells within 1,500 feet of a water supply well shall be flow- and quality-tested by the operator at the request of the drinking well owner prior to operation of the water supply well.

- For each proposed multi-site impoundment water source identified in your water management plan (if applicable), DEP will review the withdrawal limits established in the referenced Water Management Plan for current suitability and provide to the operator these limits for each identified intake. Note that withdrawal limits may be modified as necessary based on changing demands upon that water supply.

Source ID: 16068	Source Name	Pennsboro Lake		Source start date:	5/10/2013
				Source end date:	5/10/2015
	Source Lat:	39.281689	Source Long:	-80.925526	County
					Ritchie
	Max. Daily Purchase (gal)			Total Volume from Source (gal):	
DEP Comments:					

Source ID: 16069	Source Name	Powers Lake (Wilderness Water Park Dam)		Source start date:	5/10/2013
		Private Owner		Source end date:	5/10/2015
	Source Lat:	39.255752	Source Long:	-80.463262	County
					Harrison
	Max. Daily Purchase (gal)			Total Volume from Source (gal):	
DEP Comments:					

---

WMP- 01175

API/ID Number 017-FWC-00009

Operator:

Antero Resources

Pearl Jean North

---

**Important:**

For each proposed secondary water source identified in your water management plan (i.e., groundwater well, lake/reservoir, recycled frac water, multi-site impoundment, out-of-state source), DEP makes no estimation of the availability of water. These sources may prove to be unsuitable water supplies. Please review the following notes:

- For groundwater supply wells, DEP recommends that the operator contact the local health department prior to drilling any new well; and reminds the operator that all drinking water wells within 1,500 feet of a water supply well shall be flow- and quality-tested by the operator at the request of the drinking well owner prior to operation of the water supply well.

- For each proposed multi-site impoundment water source identified in your water management plan (if applicable), DEP will review the withdrawal limits established in the referenced Water Management Plan for current suitability and provide to the operator these limits for each identified intake. Note that withdrawal limits may be modified as necessary based on changing demands upon that water supply.

---

Source ID:	16070	Source Name	Powers Lake Two		Source start date:	5/10/2013	
					Source end date:	5/10/2015	
		Source Lat:	39.247604	Source Long:	-80.466642	County	Harrison
		Max. Dally Purchase (gal)		Total Volume from Source (gal):			

DEP Comments:

---

WMP-01175

API/ID Number 017-FWC-00009

Operator:

Antero Resources

Pearl Jean North

---

**Important:**

For each proposed secondary water source identified in your water management plan (i.e., groundwater well, lake/reservoir, recycled frac water, multi-site impoundment, out-of-state source), DEP makes no estimation of the availability of water. These sources may prove to be unsuitable water supplies. Please review the following notes:

- For groundwater supply wells, DEP recommends that the operator contact the local health department prior to drilling any new well; and reminds the operator that all drinking water wells within 1,500 feet of a water supply well shall be flow- and quality-tested by the operator at the request of the drinking well owner prior to operation of the water supply well.

- For each proposed multi-site impoundment water source identified in your water management plan (if applicable), DEP will review the withdrawal limits established in the referenced Water Management Plan for current suitability and provide to the operator these limits for each identified intake. Note that withdrawal limits may be modified as necessary based on changing demands upon that water supply.

---

**Other**

Source ID: 16071 Source Name Poth Lake (Landowner Pond) Source start date: 5/10/2013  
Private Owner Source end date: 5/10/2015  
Source Lat: 39.221306 Source Long: -80.463028 County Harrison  
Max. Daily Purchase (gal) Total Volume from Source (gal):

DEP Comments:

---

Source ID: 16072 Source Name Williamson Pond (Landowner Pond) Source start date: 5/10/2013  
Source end date: 5/10/2015  
Source Lat: 39.19924 Source Long: -80.886161 County Ritchie  
Max. Daily Purchase (gal) Total Volume from Source (gal):

DEP Comments:

---

## Pearl Jean North

**Important:**

For each proposed secondary water source identified in your water management plan (i.e., groundwater well, lake/reservoir, recycled frac water, multi-site impoundment, out-of-state source), DEP makes no estimation of the availability of water. These sources may prove to be unsuitable water supplies. Please review the following notes:

- For groundwater supply wells, DEP recommends that the operator contact the local health department prior to drilling any new well; and reminds the operator that all drinking water wells within 1,500 feet of a water supply well shall be flow- and quality-tested by the operator at the request of the drinking well owner prior to operation of the water supply well.

- For each proposed multi-site impoundment water source identified in your water management plan (if applicable), DEP will review the withdrawal limits established in the referenced Water Management Plan for current suitability and provide to the operator these limits for each identified intake. Note that withdrawal limits may be modified as necessary based on changing demands upon that water supply.

Source ID: 16073	Source Name	Eddy Pond (Landowner Pond)		Source start date:	5/10/2013
				Source end date:	5/10/2015
	Source Lat:	39.19924	Source Long:	-80.886161	County
					Ritchie
	Max. Daily Purchase (gal)			Total Volume from Source (gal):	
DEP Comments:					

Source ID: 16074	Source Name	Hog Lick Quarry Industrial Facility		Source start date:	5/10/2013
				Source end date:	5/10/2015
	Source Lat:	39.419272	Source Long:	-80.217941	County
					Marion
	Max. Daily Purchase (gal)	1,000,000		Total Volume from Source (gal):	
DEP Comments:					

---

WMP-01175

API/ID Number 017-FWC-00009

Operator:

Antero Resources

Pearl Jean North

---

**Important:**

For each proposed secondary water source identified in your water management plan (i.e., groundwater well, lake/reservoir, recycled frac water, multi-site impoundment, out-of-state source), DEP makes no estimation of the availability of water. These sources may prove to be unsuitable water supplies. Please review the following notes:

- For groundwater supply wells, DEP recommends that the operator contact the local health department prior to drilling any new well; and reminds the operator that all drinking water wells within 1,500 feet of a water supply well shall be flow- and quality-tested by the operator at the request of the drinking well owner prior to operation of the water supply well.

- For each proposed multi-site impoundment water source identified in your water management plan (if applicable), DEP will review the withdrawal limits established in the referenced Water Management Plan for current suitability and provide to the operator these limits for each identified intake. Note that withdrawal limits may be modified as necessary based on changing demands upon that water supply.

---

Source ID:	16075	Source Name	Glade Fork Mine Industrial Facility	Source start date:	5/10/2013	
				Source end date:	5/10/2015	
	Source Lat:	38.965767	Source Long:	-80.299313	County	Upshur
	Max. Daily Purchase (gal)	1,000,000	Total Volume from Source (gal):			

DEP Comments:



west virginia department of environmental protection  
 601 57th Street SE  
 Charleston, WV 25304-2345

**WATER MANAGEMENT PLAN/  
 WATER ADDENDUM**  
**Centralized Impoundments and Pits**  
 Office of Oil and Gas  
 Phone: (304) 928-0450

DEP Office Use only	
Date Received by Oil & Gas:	
Administratively Complete - Oil & Gas: <input type="checkbox"/> Yes <input type="checkbox"/> No	
Date Received by Water Use:	
Complete - Water Use: <input checked="" type="checkbox"/> Yes <input type="checkbox"/> No <b>SH</b>	

**Section I - Operator Information**

Identifier (assigned by Oil & Gas): 012-FWC-0009  
 Modification?

Operator Name: <b>Antero Resources Appalachian Corporation</b>	
Operator ID: <b>494488557</b>	*Registered in the Frac Water Reporting Website? Yes <input checked="" type="checkbox"/> No <input type="checkbox"/>
Mailing Address: <b>1625 17th Street Denver CO 80202</b>	Contact Name/Title (Water Resources Manager): <b>Amanda Fernley/ Environmental and Regulatory Analyst</b>
Contact Phone: <b>(303) 357- 6736</b>	Contact Email: <b>afernley@anteroresources.com</b>

\*If no, the operator will be required to register with the WVDEP Water Use Section; contact [dep.water.use@wv.gov](mailto:dep.water.use@wv.gov)

**Section II - Impoundment/Pit Overview**

Impoundment/Pit Name: <b>Pearl Jean North</b>			
<input checked="" type="checkbox"/> Centralized Impoundment (Freshwater)	Location (decimal degrees, NAD 83)		
	Latitude: <b>39.288155</b>	Longitude: <b>-80.674637</b>	County: <b>Doddridge</b>
<input type="checkbox"/> Centralized Waste Pit	Landowner name and address: <b>Dean R. &amp; Martha A. Pennington Rt. 2, Box 207, West Union, WV 26456</b>		
			Phone:

**Section III - Source Water Overview (check all that apply)**

<input checked="" type="checkbox"/> Streams/Rivers	<input checked="" type="checkbox"/> Lakes/Reservoirs/Pond	<input type="checkbox"/> Ground Water	<input checked="" type="checkbox"/> Purchased Water (PSD)
<input checked="" type="checkbox"/> Purchased Water (Private)	<input type="checkbox"/> Recycled Frac Water	Other (describe):	
Total impoundment/pit capacity (gal): <b>4271723</b>			<b>APR 12 2013</b>

Department of Environmental Protection



**Section III(a) - Surface Water Source (to be completed for each surface water withdrawal location, print additional pages as necessary)**

Source Name: Ohio River at Bens Run Withdrawal		
Location (decimal degrees, NAD 83)		
Latitude: 39.465930	Longitude: -81.110781	County: Tyler
Landowner name and address: Bens Run Land Company Limited Partnership 1105 Schrock Road, Suite 602 Columbus, OH 43229		Phone:
Obtained Landowner Permission? Yes <input checked="" type="checkbox"/> No <input type="checkbox"/>		

**Proposed Withdrawal Details**

Start Date:	End Date:	Total Withdrawal from Source (gal):	Max. Pump Rate (gpm): 3360 gpm
No. of Pump Trucks: N/A	Max. Pump Rate per Truck (gpm): N/A	No. Trucks Simultaneously Pumping: N/A	

**Determination that sufficient flow is available downstream from proposed intake point**

Allow passby to be calculated by the DEP (Preferred)? Yes <input checked="" type="checkbox"/> No <input type="checkbox"/> (If no, advance written authorization by DEP is required. Attach authorization and details.)
---

**Aquatic Life Protection**

<p><b>Describe Entrainment and Impingement Prevention Plan:</b></p> <p>Fish screens will be installed on the water withdrawal intake hoses to prevent losses of resident fresh water fish with a minimum fork length of 5 mm (approx. 1 inch). The sizing of the fish screens will also afford protection of mussels. The water withdrawal hoses will be installed a minimum of 300 mm (12 in) above the bottom of the watercourse to prevent entrainment of sediment and aquatic organisms associated with the streambed.</p>
<p><b>Describe Invasive Species Transfer Prevention Plan:</b></p> <p>Water withdrawal trucks and intake hoses will be disinfected on a routine basis. Withdrawal trucks will be blown out at the conclusion of each day. In addition, individual trucking companies will be assigned to a specific withdrawal point to prevent the transfer of aquatic life between surface water sources.</p>

**Stream details**

<b>DEP Office Use Only</b>			
Contact Recreation <input type="checkbox"/>	Aquatic Life-Trout Water <input type="checkbox"/>	Aquatic Life-Warm Water <input type="checkbox"/>	Drinking Water Supply <input type="checkbox"/>
Industrial <input type="checkbox"/>	Agriculture <input type="checkbox"/>	Irrigation <input type="checkbox"/>	Reference Gauge:
Gauged Stream : <input type="checkbox"/>	Stream Final Code:	Regulated by:	
Trout? <input type="checkbox"/>	Sensitive Aquatic Species? <input type="checkbox"/>	Tier 3 Stream? <input type="checkbox"/>	Within 1 mile upstream of a PSD? Yes <input type="checkbox"/> No <input type="checkbox"/>
Mussels? <input type="checkbox"/>	Upstream Drainage Area?		

**Section III(a) - Surface Water Source (to be completed for each surface water withdrawal location, print additional pages as necessary)**

Source Name: <b>West Fork River at JCP Withdrawal</b>		
Location (decimal degrees, NAD 83)		
Latitude: <b>39.3209139</b>	Longitude: <b>-80.3375722</b>	County: <b>Harrison</b>
Landowner name and address: <b>James &amp; Brenda Raines PO Box 446, Lumberport WV 26386; Clarence Mutschelknaus 107 E. Main St, Salem WV 26426; Patrick Deem, Jr. 623 Rivendell Dr, Bridgeport WV 26330</b>		Phone: <b>James Raines (304) 641- 9594</b>
Obtained Landowner Permission?    Yes <input checked="" type="checkbox"/> No <input type="checkbox"/>		

**Proposed Withdrawal Details**

Start Date:	End Date:	Total Withdrawal from Source (gal):	Max. Pump Rate (gpm): <b>2000 gpm</b>
No. of Pump Trucks: <b>N/A</b>	Max. Pump Rate per Truck (gpm): <b>N/A</b>	No. Trucks Simultaneously Pumping: <b>N/A</b>	

**Determination that sufficient flow is available downstream from proposed intake point**

Allow passby to be calculated by the DEP (Preferred)?    Yes <input type="checkbox"/> No <input type="checkbox"/>
(If no, advance written authorization by DEP is required. Attach authorization and details.)

**Aquatic Life Protection**

Describe Entrainment and Impingement Prevention Plan: Fish screens will be installed on the water withdrawal intake hoses to prevent losses of resident fresh water fish with a minimum fork length of 5 mm (approx. 1 inch). The sizing of the fish screens will also afford protection of mussels. The water withdrawal hoses will be installed a minimum of 300 mm (12 in) above the bottom of the watercourse to prevent entrainment of sediment and aquatic organisms associated with the streambed.
Describe Invasive Species Transfer Prevention Plan: Water withdrawal trucks and intake hoses will be disinfected on a routine basis. Withdrawal trucks will be blown out at the conclusion of each day. In addition, individual trucking companies will be assigned to a specific withdrawal point to prevent the transfer of aquatic life between surface water sources.

**Stream details**

DEP Office Use Only			
Contact Recreation <input type="checkbox"/>	Aquatic Life-Trout Water <input type="checkbox"/>	Aquatic Life-Warm Water <input type="checkbox"/>	Drinking Water Supply <input checked="" type="checkbox"/> <b>12 2013</b>
Industrial <input type="checkbox"/>	Agriculture <input type="checkbox"/>	Irrigation <input type="checkbox"/>	Reference Gauge: <input type="checkbox"/>
Gauged Stream : <input type="checkbox"/>	Stream Final Code:	Regulated by: <b>Department of Environmental Protection</b>	
Trout? <input type="checkbox"/>	Sensitive Aquatic Species? <input type="checkbox"/>	Tier 3 Stream? <input type="checkbox"/>	Within 1 mile upstream of a PSD? Yes <input type="checkbox"/> No <input type="checkbox"/>
Mussels? <input type="checkbox"/>	Upstream Drainage Area?		

**RECEIVED**  
**Office of Oil and Gas**  
**Department of Environmental Protection**

**Section III(a) - Surface Water Source (to be completed for each surface water withdrawal location, print additional pages as necessary)**

Source Name: <b>West Fork River at McDonald</b>		
Location (decimal degrees, NAD 83)		
Latitude: 39.16761	Longitude: 80.45069	County: Harrison
Landowner name and address: <b>William M McDonald RR2 Box 215A, Jane lew, WV, 26378</b>		Phone: 304-677-5944
Obtained Landowner Permission? Yes <input checked="" type="checkbox"/> No <input type="checkbox"/>		

**Proposed Withdrawal Details**

Start Date:	End Date:	Total Withdrawal from Source (gal):	Max. Pump Rate (gpm): 3000
No. of Pump Trucks: N/A	Max. Pump Rate per Truck (gpm): N/A	No. Trucks Simultaneously Pumping: N/A	

**Determination that sufficient flow is available downstream from proposed intake point**

Allow passby to be calculated by the DEP (Preferred)? Yes <input checked="" type="checkbox"/> No <input type="checkbox"/> (If no, advance written authorization by DEP is required. Attach authorization and details.)
---

**Aquatic Life Protection**

<b>Describe Entrainment and Impingement Prevention Plan:</b> Fish screens will be installed on the water withdrawal intake hoses to prevent losses of resident fresh water fish with a minimum fork length of 5 mm (approx. 1 inch). The sizing of the fish screens will also afford protection of mussels. The water withdrawal hoses will be installed a minimum of 300 mm (12 in) above the bottom of the watercourse to prevent entrainment of sediment and aquatic organisms associated with the streambed.
<b>Describe Invasive Species Transfer Prevention Plan:</b> Water withdrawal trucks and intake hoses will be disinfected on a routine basis. Withdrawal trucks will be blown out at the conclusion of each day. In addition, individual trucking companies will be assigned to a specific withdrawal point to prevent the transfer of aquatic life between the withdrawal locations.

**Stream details**

<b>DEP Office Use Only</b>			
Contact Recreation <input type="checkbox"/>	Aquatic Life-Trout Water <input type="checkbox"/>	Aquatic Life-Warm Water <input type="checkbox"/>	Drinking Water Supply <input type="checkbox"/>
Industrial <input type="checkbox"/>	Agriculture <input type="checkbox"/>	Irrigation <input type="checkbox"/>	Reference Gauge <input type="checkbox"/>
Gauged Stream <input type="checkbox"/>	Stream Final Code:	Regulated by:	
Trout? <input type="checkbox"/>	Sensitive Aquatic Species? <input type="checkbox"/>	Tier 3 Stream? <input type="checkbox"/>	Within 1 mile upstream of a PSD? Yes <input type="checkbox"/> No <input checked="" type="checkbox"/>
Mussels? <input type="checkbox"/>	Upstream Drainage Area?		

**RECEIVED**  
**Office of Oil and Gas**  
APR 19 2013  
WV Department of  
Environmental Protection

**Section III(a) - Surface Water Source (to be completed for each surface water withdrawal location, print additional pages as necessary)**

Source Name: <b>West Fork River at GAL Withdrawal</b>		
Location (decimal degrees, NAD 83)		
Latitude: 39.16422	Longitude: -80.45173	County: Harrison
Landowner name and address: <b>David Shrieves PO Box 215Z Jane Lew WV 26378</b>		Phone: 304-745-3546
Obtained Landowner Permission? Yes <input checked="" type="checkbox"/> No <input type="checkbox"/>		

**Proposed Withdrawal Details**

Start Date:	End Date:	Total Withdrawal from Source (gal):	Max. Pump Rate (gpm): <b>2000 gpm</b>
No. of Pump Trucks: <b>N/A</b>	Max. Pump Rate per Truck (gpm): <b>N/A</b>	No. Trucks Simultaneously Pumping: <b>N/A</b>	

**Determination that sufficient flow is available downstream from proposed intake point**

Allow passby to be calculated by the DEP (Preferred)? Yes <input type="checkbox"/> No <input type="checkbox"/> (If no, advance written authorization by DEP is required. Attach authorization and details.)
--

**Aquatic Life Protection**

<p><b>Describe Entrainment and Impingement Prevention Plan:</b> Fish screens will be installed on the water withdrawal intake hoses to prevent losses of resident fresh water fish with a minimum fork length of 5 mm (approx. 1 inch). The sizing of the fish screens will also afford protection of mussels. The water withdrawal hoses will be installed a minimum of 300 mm (12 in) above the bottom of the watercourse to prevent entrainment of sediment and aquatic organisms associated with the streambed.</p> <p><b>Describe Invasive Species Transfer Prevention Plan:</b> Water withdrawal trucks and intake hoses will be disinfected on a routine basis. Withdrawal trucks will be blown out at the conclusion of each day. In addition, individual trucking companies will be assigned to a specific withdrawal point to prevent the transfer of aquatic life between surface water sources.</p>
---

**Stream details**

<b>DEP Office Use Only</b>			
Contact Recreation <input type="checkbox"/>	Aquatic Life-Trout Water <input type="checkbox"/>	Aquatic Life-Warm Water <input type="checkbox"/>	Drinking Water Supply <input type="checkbox"/>
Industrial <input type="checkbox"/>	Agriculture <input type="checkbox"/>	Irrigation <input type="checkbox"/>	Reference Gauge <input type="checkbox"/>
Gauged Stream: <input type="checkbox"/>	Stream Final Code:	Regulated by:	
Trout? <input type="checkbox"/>	Sensitive Aquatic Species? <input type="checkbox"/>	Tier 3 Stream? <input type="checkbox"/>	Within 1 mile of PSD? Yes <input type="checkbox"/> No <input type="checkbox"/>
Mussels? <input type="checkbox"/>	Upstream Drainage Area?		

**RECEIVED**  
**Office of Oil and Gas**  
**APR 12 2013**  
**WV Department of Environmental Protection**

**Section III(a) - Surface Water Source (to be completed for each surface water withdrawal location, print additional pages as necessary)**

Source Name: <b>Middle Island Creek at Dawson Withdrawal</b>			
Location (decimal degrees, NAD 83)			
Latitude: <b>39.379292</b>	Longitude: <b>-80.867803</b>	County: <b>Tyler</b>	
Landowner name and address: <b>Gary D Dawson and Rella A Dawson HC 69, Box 31A, Alma, West Virginia, 26320</b>		Phone: <b>(304)-758-0160</b>	
Obtained Landowner Permission? Yes <input checked="" type="checkbox"/> No <input type="checkbox"/>			

**Proposed Withdrawal Details**

Start Date:	End Date:	Total Withdrawal from Source (gal):	Max. Pump Rate (gpm): <b>3000</b>
No. of Pump Trucks: <b>N/A</b>	Max. Pump Rate per Truck (gpm): <b>N/A</b>	No. Trucks Simultaneously Pumping: <b>N/A</b>	

**Determination that sufficient flow is available downstream from proposed intake point**

Allow passby to be calculated by the DEP (Preferred)? Yes <input checked="" type="checkbox"/> No <input type="checkbox"/>
(If no, advance written authorization by DEP is required. Attach authorization and details.)

**Aquatic Life Protection**

Describe Entrainment and Impingement Prevention Plan: Fish screens will be installed on the water withdrawal intake hoses to prevent losses of resident fresh water fish with a minimum fork length of 5 mm (approx. 1 inch). The sizing of the fish screens will also afford protection of mussels. The water withdrawal hoses will be installed a minimum of 300 mm (12 in) above the bottom of the watercourse to prevent entrainment of sediment and aquatic organisms associated with the streambed.
Describe Invasive Species Transfer Prevention Plan: Water withdrawal trucks and intake hoses will be disinfected on a routine basis. Withdrawal trucks will be blown out at the conclusion of each day. In addition, individual trucking companies will be assigned to a specific withdrawal point to prevent the transfer of aquatic life between surface water sources.

**Stream details**

<b>DEP Office Use Only</b>			
Contact Recreation <input checked="" type="checkbox"/>	Aquatic Life-Trout Water <input type="checkbox"/>	Aquatic Life-Warm Water <input type="checkbox"/>	Drinking Water Supply <input type="checkbox"/>
Industrial <input type="checkbox"/>	Agriculture <input type="checkbox"/>	Irrigation <input type="checkbox"/>	Reference Gauge: <input type="checkbox"/>
Gauged Stream <input type="checkbox"/>	Stream Final Code:	Regulated by:	
Trout? <input type="checkbox"/>	Sensitive Aquatic Species? <input type="checkbox"/>	Tier 3 Stream? <input type="checkbox"/>	Within 1 mile upstream of a PSD? Yes <input type="checkbox"/> No <input type="checkbox"/>
Mussels? <input type="checkbox"/>	Upstream Drainage Area:		

**RECEIVED**  
**Water and Gas**  
**APR 12 2013**  
**Department of Environmental Protection**

**Section III(a) - Surface Water Source (to be completed for each surface water withdrawal location, print additional pages as necessary)**

Source Name: <b>McElroy Creek at Forest Withdrawal</b>		
Location (decimal degrees, NAD 83)		
Latitude: <b>39.39675</b>	Longitude: <b>80.738197</b>	County: <b>Tyler</b>
Landowner name and address: <b>Forest C. Moore, Jr. and Brenda L. Moore HC 67 Box 157 West Union, WV 26456</b>		Phone: <b>(304) 758-5127</b>
Obtained Landowner Permission? Yes <input checked="" type="checkbox"/> No <input type="checkbox"/>		

**Proposed Withdrawal Details**

Start Date:	End Date:	Total Withdrawal from Source (gal):	Max. Pump Rate (gpm): <b>1000 gpm</b>
No. of Pump Trucks: <b>N/A</b>	Max. Pump Rate per Truck (gpm): <b>N/A</b>	No. Trucks Simultaneously Pumping: <b>N/A</b>	

**Determination that sufficient flow is available downstream from proposed intake point**

Allow passby to be calculated by the DEP (Preferred)? Yes <input checked="" type="checkbox"/> No <input type="checkbox"/> (If no, advance written authorization by DEP is required. Attach authorization and details.)
---

**Aquatic Life Protection**

<p><b>Describe Entrainment and Impingement Prevention Plan:</b> Fish screens will be installed on the water withdrawal intake hoses to prevent losses of resident fresh water fish with a minimum fork length of 5 mm (approx. 1 inch). The sizing of the fish screens will also afford protection of mussels. The water withdrawal hoses will be installed a minimum of 300 mm (12 in) above the bottom of the watercourse to prevent entrainment of sediment and aquatic organisms associated with the streambed.</p>
<p><b>Describe Invasive Species Transfer Prevention Plan:</b> Water withdrawal trucks and intake hoses will be disinfected on a routine basis. Withdrawal trucks will be blown out at the conclusion of each day. In addition, individual trucking companies will be assigned to a specific withdrawal point to prevent the transfer of aquatic life between surface water sources.</p>

**Stream details**

<b>DEP Office Use Only</b>			
Contact Recreation <input type="checkbox"/>	Aquatic Life-Trout Water <input type="checkbox"/>	Aquatic Life-Warm Water <input type="checkbox"/>	Drinking Water Supply <input type="checkbox"/>
Industrial <input type="checkbox"/>	Agriculture <input type="checkbox"/>	Irrigation <input type="checkbox"/>	Reference Gauge: <input type="checkbox"/>
Gauged Stream? <input type="checkbox"/>	Stream Final Code:	Regulated by:	
Trout? <input type="checkbox"/>	Sensitive Aquatic Species? <input type="checkbox"/>	Tier 3 Stream? <input type="checkbox"/>	Within 1 mile upstream of PSD? Yes <input type="checkbox"/>
Mussels? <input type="checkbox"/>	Upstream Drainage Area?		

**RECEIVED**  
**Office of Oil and Gas**

**Apr 12 2013**

**Department of Environmental Protection**  
Page | 5

**Section III(a) - Surface Water Source (to be completed for each surface water withdrawal location, print additional pages as necessary)**

Source Name: <b>McElroy Creek at Sweeney Withdrawal</b>		
Location (decimal degrees, NAD 83)		
Latitude: 39.398123	Longitude: -80.656808	County: Doddridge
Landowner name and address: <b>Bill Sweeney PO Box 126 Mannington, WV 26582</b>		Phone: 304-986-1432
Obtained Landowner Permission? Yes <input checked="" type="checkbox"/> No <input type="checkbox"/>		

**Proposed Withdrawal Details**

Start Date:	End Date:	Total Withdrawal from Source (gal):	Max. Pump Rate (gpm): 1000 gpm
No. of Pump Trucks: N/A	Max. Pump Rate per Truck (gpm): N/A	No. Trucks Simultaneously Pumping: N/A	

**Determination that sufficient flow is available downstream from proposed intake point**

Allow passby to be calculated by the DEP (Preferred)? Yes <input checked="" type="checkbox"/> No <input type="checkbox"/> (If no, advance written authorization by DEP is required. Attach authorization and details.)
---

**Aquatic Life Protection**

<p><b>Describe Entrainment and Impingement Prevention Plan:</b> Fish screens will be installed on the water withdrawal intake hoses to prevent losses of resident fresh water fish with a minimum fork length of 5 mm (approx. 1 inch). The sizing of the fish screens will also afford protection of mussels. The water withdrawal hoses will be installed a minimum of 300 mm (12 in) above the bottom of the watercourse to prevent entrainment of sediment and aquatic organisms associated with the streambed.</p>
<p><b>Describe Invasive Species Transfer Prevention Plan:</b> Water withdrawal trucks and intake hoses will be disinfected on a routine basis. Withdrawal trucks will be blown out at the conclusion of each day. In addition, individual trucking companies will be assigned to a specific withdrawal point to prevent the transfer of aquatic life between surface water sources.</p>

**Stream details**

<b>DEP Office Use Only</b>			
Contact Recreation <input type="checkbox"/>	Aquatic Life-Trout Water <input type="checkbox"/>	Aquatic Life-Warm Water <input type="checkbox"/>	Drinking Water Supply <input type="checkbox"/>
Industrial <input type="checkbox"/>	Agriculture <input type="checkbox"/>	Irrigation <input type="checkbox"/>	Reference Gauge <input type="checkbox"/>
Gauged Stream <input type="checkbox"/>	Stream Final Code:	Regulated by:	
Trout? <input type="checkbox"/>	Sensitive Aquatic Species? <input type="checkbox"/>	Tier 3 Stream? <input type="checkbox"/>	Withdrawal upstream of a PSD? Yes <input type="checkbox"/> No <input type="checkbox"/>
Mussels? <input type="checkbox"/>	Upstream Drainage Area?		

**RECEIVED**  
**Office of Oil and Gas**  
**APR 12 2013**  
**Department of Environmental Protection**

**Section III(a) - Surface Water Source (to be completed for each surface water withdrawal location, print additional pages as necessary)**

Source Name: <b>Meathouse Fork at Gagnon Withdrawal</b>			
Location (decimal degrees, NAD 83)			
Latitude: 39.260540	Longitude: -80.720998	County: Doddridge	
Landowner name and address: <b>George L. Gagnon and Susan C. Gagnon Rt.1 Box 312, West Union, West Virginia</b>		Phone: 304-709-4029	
Obtained Landowner Permission? Yes <input checked="" type="checkbox"/> No <input type="checkbox"/>			

**Proposed Withdrawal Details**

Start Date:	End Date:	Total Withdrawal from Source (gal):	Max. Pump Rate (gpm): <b>1000</b>
No. of Pump Trucks: <b>N/A</b>	Max. Pump Rate per Truck (gpm): <b>N/A</b>	No. Trucks Simultaneously Pumping: <b>N/A</b>	

**Determination that sufficient flow is available downstream from proposed intake point**

Allow passby to be calculated by the DEP (Preferred)? Yes <input checked="" type="checkbox"/> No <input type="checkbox"/> (If no, advance written authorization by DEP is required. Attach authorization and details.)
---

**Aquatic Life Protection**

<p><b>Describe Entrainment and Impingement Prevention Plan:</b> Fish screens will be installed on the water withdrawal intake hoses to prevent losses of resident fresh water fish with a minimum fork length of 5 mm (approx. 1 inch). The sizing of the fish screens will also afford protection of mussels. The water withdrawal hoses will be installed a minimum of 300 mm (12 in) above the bottom of the watercourse to prevent entrainment of sediment and aquatic organisms associated with the streambed.</p>
<p><b>Describe Invasive Species Transfer Prevention Plan:</b> Water withdrawal trucks and intake hoses will be disinfected on a routine basis. Withdrawal trucks will be blown out at the conclusion of each day. In addition, individual trucking companies will be assigned to a specific withdrawal point to prevent the transfer of aquatic life between surface water sources.</p>

**Stream details**

<b>DEP Office Use Only</b>			
Contact Recreation <input type="checkbox"/>	Aquatic Life-Trout Water <input type="checkbox"/>	Aquatic Life-Warm Water <input type="checkbox"/>	Drinking Water Supply <input type="checkbox"/>
Industrial <input type="checkbox"/>	Agriculture <input type="checkbox"/>	Irrigation <input type="checkbox"/>	Reference Gauge: <input type="checkbox"/>
Gauged Stream: <input type="checkbox"/>	Stream Final Code:	Regulated by:	
Trout? <input type="checkbox"/>	Sensitive Aquatic Species? <input type="checkbox"/>	Tier 3 Stream? <input type="checkbox"/>	Within 1 mile of... Yes <input type="checkbox"/>
Mussels? <input type="checkbox"/>	Upstream Drainage Area?		

**RECEIVED**  
**Office of Oil and Gas**  
**APR 12 2013**  
**Department of Environmental Protection**



**Section III(a) - Surface Water Source (to be completed for each surface water withdrawal location, print additional pages as necessary)**

Source Name: <b>Meathouse Creek at Whitehair Withdrawal</b>		
Location (decimal degrees, NAD 83)		
Latitude: 39.211317	Longitude: -80.679592	County: Doddridge
Landowner name and address: <b>Elton Whitehair 3108 Meathouse Fork Road New Milton WV 26411</b>		Phone: 304-873-1351
Obtained Landowner Permission? Yes <input checked="" type="checkbox"/> No <input type="checkbox"/>		

**Proposed Withdrawal Details**

Start Date:	End Date:	Total Withdrawal from Source (gal):	Max. Pump Rate (gpm): 1000
No. of Pump Trucks: N/A	Max. Pump Rate per Truck (gpm): N/A	No. Trucks Simultaneously Pumping: N/A	

**Determination that sufficient flow is available downstream from proposed intake point**

Allow passby to be calculated by the DEP (Preferred)? Yes <input checked="" type="checkbox"/> No <input type="checkbox"/> (If no, advance written authorization by DEP is required. Attach authorization and details.)
---

**Aquatic Life Protection**

<p><b>Describe Entrainment and Impingement Prevention Plan:</b> Fish screens will be installed on the water withdrawal intake hoses to prevent losses of resident fresh water fish with a minimum fork length of 5 mm (approx. 1 inch). The sizing of the fish screens will also afford protection of mussels. The water withdrawal hoses will be installed a minimum of 300 mm (12 in) above the bottom of the watercourse to prevent entrainment of sediment and aquatic organisms associated with the streambed.</p>
<p><b>Describe Invasive Species Transfer Prevention Plan:</b> Water withdrawal trucks and intake hoses will be disinfected on a routine basis. Withdrawal trucks will be blown out at the conclusion of each day. In addition, individual trucking companies will be assigned to a specific withdrawal point to prevent the transfer of aquatic life between surface water sources.</p>

**Stream details**

<b>DEP Office Use Only</b>			
Contact Recreation <input type="checkbox"/>	Aquatic Life-Trout Water <input type="checkbox"/>	Aquatic Life-Warm Water <input type="checkbox"/>	Drinking Water Supply <input type="checkbox"/>
Industrial <input type="checkbox"/>	Agriculture <input type="checkbox"/>	Irrigation <input type="checkbox"/>	Reference Gauge: <input type="checkbox"/>
Gauged Stream <input type="checkbox"/>	Stream Final Code:	Regulated by:	
Trout? <input type="checkbox"/>	Sensitive Aquatic Species? <input type="checkbox"/>	Tier 3 Stream? <input type="checkbox"/>	Within 1 mile upstream of a PSD? Yes <input type="checkbox"/> No <input type="checkbox"/>
Mussels? <input type="checkbox"/>	Upstream Drainage Area?		

**RECEIVED**  
**Office of Oil and Gas**  
**APR 12 2013**  
**Department of Environmental Protection**

**Section III(a) - Surface Water Source (to be completed for each surface water withdrawal location, print additional pages as necessary)**

Source Name: Tom's Fork at Erwin		
Location (decimal degrees, NAD 83)		
Latitude: 39.174306	Longitude: -80.702992	County: Doddridge
Landowner name and address: John F. Erwin and Sandra E. Erwin 12222 WV Rt. 18 South, New Milton, WV 26411		Phone: (304) 873-1885
Obtained Landowner Permission? Yes <input checked="" type="checkbox"/> No <input type="checkbox"/>		

**Proposed Withdrawal Details**

Start Date:	End Date:	Total Withdrawal from Source (gal):	Max. Pump Rate (gpm): 1000 gpm
No. of Pump Trucks: N/A	Max. Pump Rate per Truck (gpm): N/A	No. Trucks Simultaneously Pumping: N/A	

**Determination that sufficient flow is available downstream from proposed intake point**

Allow passby to be calculated by the DEP (Preferred)? Yes <input type="checkbox"/> No <input type="checkbox"/>
(If no, advance written authorization by DEP is required. Attach authorization and details.)

**Aquatic Life Protection**

<p><b>Describe Entrainment and Impingement Prevention Plan:</b></p> <p>Fish screens will be installed on the water withdrawal intake hoses to prevent losses of resident fresh water fish with a minimum fork length of 5 mm (approx. 1 inch). The sizing of the fish screens will also afford protection of mussels. The water withdrawal hoses will be installed a minimum of 300 mm (12 in) above the bottom of the watercourse to prevent entrainment of sediment and aquatic organisms associated with the streambed.</p>
<p><b>Describe Invasive Species Transfer Prevention Plan:</b></p> <p>Water withdrawal trucks and intake hoses will be disinfected on a routine basis. Withdrawal trucks will be blown out at the conclusion of each day. In addition, individual trucking companies will be assigned to a specific withdrawal point to prevent the transfer of aquatic life between surface water sources.</p>

**Stream details**

<b>DEP Office Use Only</b>			
Contact Recreation <input type="checkbox"/>	Aquatic Life-Trout Water <input type="checkbox"/>	Aquatic Life-Warm Water <input type="checkbox"/>	Drinking Water Supply <input type="checkbox"/>
Industrial <input type="checkbox"/>	Agriculture <input type="checkbox"/>	Irrigation <input type="checkbox"/>	Reference Gauge: <input type="checkbox"/>
Gauged Stream? <input type="checkbox"/>	Stream Final Code:	Regulated by:	
Trout? <input type="checkbox"/>	Sensitive Aquatic Species? <input type="checkbox"/>	Tier 3 Stream? <input type="checkbox"/>	Withdrawal upstream of a PSD? Yes <input type="checkbox"/> No <input type="checkbox"/>
Mussels? <input type="checkbox"/>	Upstream Drainage Area?		

**RECEIVED**  
**Department of Oil and Gas**  
**Department of Environmental Protection**  
**APR 12 2015**

**Section III(a) - Surface Water Source (to be completed for each surface water withdrawal location, print additional pages as necessary)**

Source Name: <b>Arnold Creek at Davis Withdrawal</b>			
Location (decimal degrees, NAD 83)			
Latitude: <b>39.300625</b>	Longitude: <b>-80.823622</b>	County: <b>Doddridge</b>	
Landowner name and address: <b>Jonathan Davis Rt. 1 Box 271 West Union WV 26456</b>		Phone: <b>(304)873-1916</b>	
Obtained Landowner Permission? Yes <input checked="" type="checkbox"/> No <input type="checkbox"/>			

**Proposed Withdrawal Details**

Start Date:	End Date:	Total Withdrawal from Source (gal):	Max. Pump Rate (gpm): <b>1000 gpm</b>
No. of Pump Trucks: <b>N/A</b>	Max. Pump Rate per Truck (gpm): <b>N/A</b>	No. Trucks Simultaneously Pumping: <b>N/A</b>	

**Determination that sufficient flow is available downstream from proposed intake point**

Allow passby to be calculated by the DEP (Preferred)? Yes <input checked="" type="checkbox"/> No <input type="checkbox"/> (If no, advance written authorization by DEP is required. Attach authorization and details.)
---

**Aquatic Life Protection**

<p><b>Describe Entrainment and Impingement Prevention Plan:</b></p> <p>Fish screens will be installed on the water withdrawal intake hoses to prevent losses of resident fresh water fish with a minimum fork length of 5 mm (approx. 1 inch). The sizing of the fish screens will also afford protection of mussels. The water withdrawal hoses will be installed a minimum of 300 mm (12 in) above the bottom of the watercourse to prevent entrainment of sediment and aquatic organisms associated with the streambed.</p>
<p><b>Describe Invasive Species Transfer Prevention Plan:</b></p> <p>Water withdrawal trucks and intake hoses will be disinfected on a routine basis. Withdrawal trucks will be blown out at the conclusion of each day. In addition, individual trucking companies will be assigned to a specific withdrawal point to prevent the transfer of aquatic life between the withdrawal locations.</p>

**Stream details**

<b>DEP Office Use Only</b>			
Contact Recreation <input type="checkbox"/>	Aquatic Life-Trout Water <input type="checkbox"/>	Aquatic Life-Warm Water <input type="checkbox"/>	Drinking Water Supply <input type="checkbox"/>
Industrial <input type="checkbox"/>	Agriculture <input type="checkbox"/>	Irrigation <input type="checkbox"/>	Reference Gauge:
Gauged Stream <input type="checkbox"/>	Stream Final Code	Regulated by:	
Trout? <input type="checkbox"/>	Sensitive Aquatic Species? <input type="checkbox"/>	Tier 3 Stream? <input type="checkbox"/>	Within 1 mile upstream of PSD? Yes <input type="checkbox"/>
Mussels? <input type="checkbox"/>	Upstream Drainage Area?		

**RECEIVED**  
**Office of Oil and Gas**  
**APR 12 2013**  
 WV Department of  
 Environmental Protection  
 Page | 9

**Section III(a) - Surface Water Source (to be completed for each surface water withdrawal location, print additional pages as necessary)**

Source Name: <b>Buckeye Creek at Powell Withdrawal</b>		
Location (decimal degrees, NAD 83)		
Latitude: <b>39.277142</b>	Longitude: <b>-80.690386</b>	County: <b>Doddridge</b>
Landowner name and address: <b>Dennis Powell Grant District Doddridge county, WV</b>		Phone:
Obtained Landowner Permission? Yes <input checked="" type="checkbox"/> No <input type="checkbox"/>		

**Proposed Withdrawal Details**

Start Date:	End Date:	Total Withdrawal from Source (gal):	Max. Pump Rate (gpm): <b>1000</b>
No. of Pump Trucks: <b>N/A</b>	Max. Pump Rate per Truck (gpm): <b>N/A</b>	No. Trucks Simultaneously Pumping: <b>N/A</b>	

**Determination that sufficient flow is available downstream from proposed intake point**

Allow passby to be calculated by the DEP (Preferred)? Yes <input checked="" type="checkbox"/> No <input type="checkbox"/> (If no, advance written authorization by DEP is required. Attach authorization and details.)
---

**Aquatic Life Protection**

Describe Entrainment and Impingement Prevention Plan: Fish screens will be installed on the water withdrawal intake hoses to prevent losses of resident fresh water fish with a minimum fork length of 5 mm (approx. 1 inch). The sizing of the fish screens will also afford protection of mussels. The water withdrawal hoses will be installed a minimum of 300 mm (12 in) above the bottom of the watercourse to prevent entrainment of sediment and aquatic organisms associated with the streambed.
Describe Invasive Species Transfer Prevention Plan: Water withdrawal trucks and intake hoses will be disinfected on a routine basis. Withdrawal trucks will be blown out at the conclusion of each day. In addition, individual trucking companies will be assigned to a specific withdrawal point to prevent the transfer of aquatic life between surface water sources.

**Stream details**

DEP Office Use Only			
Contact Recreation <input type="checkbox"/>	Aquatic Life-Trout Water <input type="checkbox"/>	Aquatic Life-Warm Water <input type="checkbox"/>	Drinking Water Supply <input type="checkbox"/>
Industrial <input type="checkbox"/>	Agriculture <input type="checkbox"/>	Irrigation <input type="checkbox"/>	Reference Gauge: <input type="checkbox"/>
Gauged Stream : <input type="checkbox"/>	Stream Final Code:	Regulated by:	
Trout? <input type="checkbox"/>	Sensitive Aquatic Species? <input type="checkbox"/>	Tier 3 Stream? <input type="checkbox"/>	Will this withdrawal be downstream of a PSD? Yes <input type="checkbox"/> No <input type="checkbox"/>
Mussels? <input type="checkbox"/>	Upstream Drainage		

**RECEIVED**  
**Office of Oil and Gas**  
**APR 1 2008**  
**WV Department of Environmental Protection**

**Section III(a) - Surface Water Source (to be completed for each surface water withdrawal location, print additional pages as necessary)**

Source Name: <b>South Fork at Knight Withdrawal</b>		
Location (decimal degrees, NAD 83)		
Latitude: 39.198369	Longitude: -80.870969	County: Ritchie
Landowner name and address: <b>Tracy C. Knight and Stephanie C. Knight P.O. Box 138 Pullman, WV 26421</b>		Phone: 304-349-2121
Obtained Landowner Permission? Yes <input checked="" type="checkbox"/> No <input type="checkbox"/>		

**Proposed Withdrawal Details**

Start Date:	End Date:	Total Withdrawal from Source (gal):	Max. Pump Rate (gpm): <b>3000 gpm</b>
No. of Pump Trucks: <b>N/A</b>	Max. Pump Rate per Truck (gpm): <b>N/A</b>	No. Trucks Simultaneously Pumping: <b>N/A</b>	

**Determination that sufficient flow is available downstream from proposed intake point**

Allow passby to be calculated by the DEP (Preferred)? Yes <input checked="" type="checkbox"/> No <input type="checkbox"/> (If no, advance written authorization by DEP is required. Attach authorization and details.)
---

**Aquatic Life Protection**

<p><b>Describe Entrainment and Impingement Prevention Plan:</b></p> <p>Fish screens will be installed on the water withdrawal intake hoses to prevent losses of resident fresh water fish with a minimum fork length of 5 mm (approx. 1 inch). The sizing of the fish screens will also afford protection of mussels. The water withdrawal hoses will be installed a minimum of 300 mm (12 in) above the bottom of the watercourse to prevent entrainment of sediment and aquatic organisms associated with the streambed.</p>
<p><b>Describe Invasive Species Transfer Prevention Plan:</b></p> <p>Water withdrawal trucks and intake hoses will be disinfected on a routine basis. Withdrawal trucks will be blown out at the conclusion of each day. In addition, individual trucking companies will be assigned to a specific withdrawal point to prevent the transfer of aquatic life between the withdrawal locations.</p>

**Stream details**

<b>DEP Office Use Only</b>			
Contact Recreation <input type="checkbox"/>	Aquatic Life-Trout Water <input type="checkbox"/>	Aquatic Life-Warm Water <input type="checkbox"/>	Reference Gauge <input type="checkbox"/>
Industrial <input type="checkbox"/>	Agriculture <input type="checkbox"/>	Irrigation <input type="checkbox"/>	
Gauged Stream: <input type="checkbox"/>	Stream Final Code:	Regulated by:	
Trout? <input type="checkbox"/>	Sensitive Aquatic Species? <input type="checkbox"/>	Tier 3 Stream? <input type="checkbox"/>	Within 1 mile up stream from PSD? Yes <input type="checkbox"/>
Mussels? <input type="checkbox"/>	Upstream Drainage Area? <input type="checkbox"/>		

**RECEIVED**  
**Office of Oil and Gas**  
**APR 12 2016**  
**Department of Environmental Protection**

**Section III(a) - Surface Water Source (to be completed for each surface water withdrawal location, print additional pages as necessary)**

Source Name: North Fork Hughes at Davis Withdrawal			
Location (decimal degrees, NAD 83)			
Latitude: 39.322363	Longitude: -80.936771	County: Ritchie	
Landowner name and address: Lewis P. Davis and Norma J. Davis 4146 Mountain Dr., Pennsboro, WV 26415		Phone: 304-659-2249	
Obtained Landowner Permission? Yes <input checked="" type="checkbox"/> No <input type="checkbox"/>			

**Proposed Withdrawal Details**

Start Date:	End Date:	Total Withdrawal from Source (gal):	Max. Pump Rate (gpm): 1000
No. of Pump Trucks: N/A	Max. Pump Rate per Truck (gpm): N/A	No. Trucks Simultaneously Pumping: N/A	

**Determination that sufficient flow is available downstream from proposed intake point**

Allow passby to be calculated by the DEP (Preferred)? Yes <input checked="" type="checkbox"/> No <input type="checkbox"/> (If no, advance written authorization by DEP is required. Attach authorization and details.)
---

**Aquatic Life Protection**

<p><b>Describe Entrainment and Impingement Prevention Plan:</b></p> <p>Fish screens will be installed on the water withdrawal intake hoses to prevent losses of resident fresh water fish with a minimum fork length of 5 mm (approx. 1 inch). The sizing of the fish screens will also afford protection of mussels. The water withdrawal hoses will be installed a minimum of 300 mm (12 in) above the bottom of the watercourse to prevent entrainment of sediment and aquatic organisms associated with the streambed.</p>
<p><b>Describe Invasive Species Transfer Prevention Plan:</b></p> <p>Water withdrawal trucks and intake hoses will be disinfected on a routine basis. Withdrawal trucks will be blown out at the conclusion of each day. In addition, individual trucking companies will be assigned to a specific withdrawal point to prevent the transfer of aquatic life between surface water sources.</p>

**Stream details**

DEP Office Use Only			
Contact: Recreation <input type="checkbox"/>	Aquatic Life-Trout Water <input type="checkbox"/>	Aquatic Life-Warm Water <input type="checkbox"/>	Drinking Water Supply <input type="checkbox"/>
Industrial <input type="checkbox"/>	Agriculture <input type="checkbox"/>	Irrigation <input type="checkbox"/>	Reference Gauge: <input type="checkbox"/>
Gauged Stream : <input type="checkbox"/>	Stream Final Code:	Regulated by:	
Trout? <input type="checkbox"/>	Sensitive Aquatic Species? <input type="checkbox"/>	Tier 3 Stream? <input type="checkbox"/>	Within 1000 ft upstream of a PSD? Yes <input type="checkbox"/> No <input type="checkbox"/>
Mussels? <input type="checkbox"/>	Upstream Drainage Area		

**RECEIVED**  
**Office of Oil and Gas**  
**APP 1/2/2013**  
**Department of Environmental Protection**

**Section III(b) - Ground Water Source (to be completed for each groundwater withdrawal location, print additional pages as necessary)**

Well Permit # (if applicable):		Well name:	
Location (decimal degrees, NAD 83)			
Latitude:	Longitude:	County:	
Aquifer: (if known)			
Landowner name and address:		Phone:	
Obtained Landowner Permission? Yes <input type="checkbox"/> No <input type="checkbox"/>		<input type="checkbox"/> *New well (Drill date: _____) <input type="checkbox"/> Existing well	

\*If drilling a new well, please submit well logs to DEP's Water Use Section; Wells must be drilled and plugged in accordance with DHHR regulations

Total Depth:	Type of Casing:	Casing Diameter:	Screen Interval:	Screen Size:
Static Water Elevation:	Top of Casing Elevation:	Surface Elevation:	Type of Well Cap:	
Withdrawal Details				
				Max. Pump Rate (gpm):

**Analysis of potential groundwater impacts**

Static Water Level Prior to Test: _____ feet below grade
Drawdown (Water Level/Elevation During Pump Test): _____ feet
Duration of Pump Test: _____ hours
Gallons Per Minute During Pump Test: _____ gpm
Time to Return to Static Water Level After Pump Test: _____ hours

**RECEIVED**  
**Office of Oil and Gas**  
 APR 12 2013  
**WV Department of**  
**Environmental Protection**

**Section III(c) - Purchased Water Source (to be completed for each water supplier, print additional pages as necessary)**

Supplier Name and Contact Information: The City of Salem 229 West Main Street Salem WV 26428			
Location(decimal degrees, NAD 83)			
Latitude: 39.28593	Longitude: -80.54605	County: Harrison	
Public Water Provider <input checked="" type="checkbox"/>	Waste Water Treatment Plant <input type="checkbox"/>	Industrial (intake locations must be provided) <input type="checkbox"/>	
Commercial Supplier (intake locations must be provided) <input type="checkbox"/>		Private (intake locations must be provided) <input type="checkbox"/>	
Purchase Details			
Start Date:	End Date:	Total Purchase from Source (gal):	Max. daily purchase (gal): 1000000
Supplier intake details:			

**Section III(d) - Lake/Reservoir Water Source (to be completed for each lake/reservoir)**

Lake/Reservoir Name: Poth Lake			
Location (decimal degrees, NAD 83)			
Latitude: 39.21945	Longitude -80.886161	County: Harrison	
Landowner name and address: Kevin J. Poth, RR1 Box 199, Lost Creek, West Virginia 26385-9742			
Permission to withdraw obtained from owner: Yes <input checked="" type="checkbox"/> No <input type="checkbox"/>		Minimum release (cfs): N/A	
Withdrawal Details			
Start Date:	End Date:	Total Withdrawal from Source (gal):	Max. Pump Rate (gpm): 1000

**RECEIVED**  
**Office of Oil and Gas**  
APR 17 2013  
**WV Department of Environmental Protection**



**Section III(c) - Purchased Water Source (to be completed for each water supplier, print additional pages as necessary)**

Supplier Name and Contact Information:			
Location(decimal degrees, NAD 83)			
Latitude:	Longitude:	County:	
Public Water Provider <input type="checkbox"/>	Waste Water Treatment Plant <input type="checkbox"/>	Industrial (intake locations must be provided) <input type="checkbox"/>	
Commercial Supplier (intake locations must be provided) <input type="checkbox"/>		Private (intake locations must be provided) <input type="checkbox"/>	
Purchase Details			
Start Date:	End Date:	Total Purchase from Source (gal):	Max. daily purchase (gal):
Supplier intake details:			

**Section III(d) - Lake/Reservoir Water Source (to be completed for each lake/reservoir)**

Lake/Reservoir Name: City of Pennsboro Lake		
Location (decimal degrees, NAD 83)		
Latitude: 39.28347	Longitude -80.92477	County: Ritchie
Landowner name and address: Nancy J. 422 Main Street Pennsboro, WV 26415		
Permission to withdraw obtained from owner: Yes <input checked="" type="checkbox"/> No <input type="checkbox"/>	Minimum release (cfs): N/A	
Withdrawal Details		
Start Date:	End Date:	Total Withdrawal from Source (gal): Max. Pump Rate (gpm):

RECEIVED  
Office of Oil and Gas  
APR 12 2013  
157 Department of  
Environmental Protection

**Section III(c) - Purchased Water Source (to be completed for each water supplier, print additional pages as necessary)**

Supplier Name and Contact Information:			
Location(decimal degrees, NAD 83)			
Latitude:	Longitude:	County:	
Public Water Provider <input type="checkbox"/>	Waste Water Treatment Plant <input type="checkbox"/>	Industrial (intake locations must be provided) <input type="checkbox"/>	
Commercial Supplier (intake locations must be provided) <input type="checkbox"/>		Private (intake locations must be provided) <input type="checkbox"/>	
Purchase Details			
Start Date:	End Date:	Total Purchase from Source (gal):	Max. daily purchase (gal):
Supplier intake details:			

**Section III(d) - Lake/Reservoir Water Source (to be completed for each lake/reservoir)**

Lake/Reservoir Name: Powers Lake			
Location (decimal degrees, NAD 83)			
Latitude:	Longitude	County:	
39.25575	-80.463262	Harrison	
Landowner name and address:			
Nancy J. Powers RR-4 Box 854 Salem West Virginia 26426-8915			
Permission to withdraw obtained from owner: Yes <input checked="" type="checkbox"/> No <input type="checkbox"/>		Minimum release (cfs): N/A	
Withdrawal Details			
Start Date:	End Date:	Total Withdrawal from Source (gal):	Max. Pump Rate (gpm):
			1000

**RECEIVED**  
Office of Oil and Gas  
APR 12 2013  
Department of Environmental Protection

**Section III(c) - Purchased Water Source (to be completed for each water supplier, print additional pages as necessary)**

Supplier Name and Contact Information:			
Location(decimal degrees, NAD 83)			
Latitude:	Longitude:	County:	
Public Water Provider <input type="checkbox"/>	Waste Water Treatment Plant <input type="checkbox"/>	Industrial (intake locations must be provided) <input type="checkbox"/>	
Commercial Supplier (intake locations must be provided) <input type="checkbox"/>		Private (intake locations must be provided) <input type="checkbox"/>	
Purchase Details			
Start Date:	End Date:	Total Purchase from Source (gal):	Max. daily purchase (gal):
Supplier intake details:			

**Section III(d) - Lake/Reservoir Water Source (to be completed for each lake/reservoir)**

Lake/Reservoir Name: Powers Lake Two			
Location (decimal degrees, NAD 83)			
Latitude: 39.2476045	Longitude: -80.4666424	County: Harrison	
Landowner name and address: Nancy J. Powers RR-4 Box 854 Salem West Virginia 26426-8915			
Permission to withdraw obtained from owner: Yes <input checked="" type="checkbox"/> No <input type="checkbox"/>		Minimum release (cfs): N/A	
Withdrawal Details			
Start Date:	End Date:	Total Withdrawal from Source (gal):	Max. Pump Rate (gpm): 4000

**RECEIVED**  
Office of Oil and Gas  
APR 12 2007  
WV Department of  
Environmental Protection

**Section III(c) - Purchased Water Source (to be completed for each water supplier, print additional pages as necessary)**

Supplier Name and Contact Information:			
Location(decimal degrees, NAD 83)			
Latitude:		Longitude:	County:
Public Water Provider <input type="checkbox"/>	Waste Water Treatment Plant <input type="checkbox"/>	Industrial (intake locations must be provided) <input type="checkbox"/>	
Commercial Supplier (intake locations must be provided) <input type="checkbox"/>		Private (intake locations must be provided) <input type="checkbox"/>	
Purchase Details			
Start Date:	End Date:	Total Purchase from Source (gal):	Max. daily purchase (gal):
Supplier intake details:			

**Section III(d) - Lake/Reservoir Water Source (to be completed for each lake/reservoir)**

Lake/Reservoir Name: Williamson Pond		
Location (decimal degrees, NAD 83)		
Latitude: 39.199379	Longitude: -80.884347	County: Ritchie
Landowner name and address: Andrew and Yolanda Williamson 783 4-Mile Creek Road Branchland, WV 25506		
Permission to withdraw obtained from owner: Yes <input checked="" type="checkbox"/> No <input type="checkbox"/>	Minimum release (cfs): N/A	
Withdrawal Details		
Start Date:	End Date:	Total Withdrawal from Source (gal):
		Max. Pump Rate (gpm):

**RECEIVED**  
**Office of Oil and Gas**  
**APR 12 2013**  
**WV Department of Environmental Protection**

**Section III(c) - Purchased Water Source (to be completed for each water supplier, print additional pages as necessary)**

Supplier Name and Contact Information:			
Location(decimal degrees, NAD 83)			
Latitude:	Longitude:	County:	
<input type="checkbox"/> Public Water Provider	<input type="checkbox"/> Waste Water Treatment Plant	<input type="checkbox"/> Industrial (Intake locations must be provided)	
<input type="checkbox"/> Commercial Supplier (intake locations must be provided)		<input type="checkbox"/> Private (intake locations must be provided)	
Purchase Details			
Start Date:	End Date:	Total Purchase from Source (gal):	Max. daily purchase (gal):
Supplier intake details:			

**Section III(d) - Lake/Reservoir Water Source (to be completed for each lake/reservoir)**

Lake/Reservoir Name: Eddy Pad Pond			
Location (decimal degrees, NAD 83)			
Latitude: 39.3352604	Longitude: -80.9275531	County: Ritchie	
Landowner name and address: Annie B Haymond 4884 Mountain Dr, Pennsboro, WV 26415			
Permission to withdraw obtained from owner: Yes <input checked="" type="checkbox"/> No <input type="checkbox"/>		Minimum release (cfs): N/A	
Withdrawal Details			
Start Date:	End Date:	Total Withdrawal from Source (gal):	Max. Pump Rate (gpm):

**RECEIVED**  
**Office of Oil and Gas**  
**APR 2 2013**  
**Department of Environmental Protection**

**Section III(c) - Purchased Water Source (to be completed for each water supplier, print additional pages as necessary)**

Supplier Name and Contact Information: Hog Lick Quarry Arthur J. Rockwell PO Box 970 Bridgeport, WV 26330			
Location(decimal degrees, NAD 83)			
Latitude: 39.4192725	Longitude: -80.2179413	County: Marion County	
Public Water Provider <input type="checkbox"/>	Waste Water Treatment Plant <input type="checkbox"/>	Industrial (intake locations must be provided) <input type="checkbox"/>	
Commercial Supplier (intake locations must be provided) <input type="checkbox"/>		Private (intake locations must be provided) <input checked="" type="checkbox"/>	
Purchase Details			
Start Date:	End Date:	Total Purchase from Source (gal):	Max. daily purchase (gal): 1000000
Supplier intake details:			

**Section III(d) - Lake/Reservoir Water Source (to be completed for each lake/reservoir)**

Lake/Reservoir Name:			
Location (decimal degrees, NAD 83)			
Latitude:	Longitude	County:	
Landowner name and address:			
Permission to withdraw obtained from owner: Yes <input type="checkbox"/> No <input type="checkbox"/>		Minimum release (cfs):	
Withdrawal Details			
Start Date:	End Date:	Total Withdrawal from Source (gal):	Max. Pump Rate (gpm):

**RECEIVED**  
 Office of Oil and Gas  
 APR 19 2013  
 Department of  
 Environmental Protection

**Section III(c) - Purchased Water Source (to be completed for each water supplier, print additional pages as necessary)**

Supplier Name and Contact Information: Glade Fork Mine Larry Alderman Rt. 3 Box 312-3 Buckannon, WV 26201			
Location(decimal degrees, NAD 83)			
Latitude: 38.9657673	Longitude: -80.2993132	County: Upshur	
Public Water Provider <input type="checkbox"/>	Waste Water Treatment Plant <input type="checkbox"/>	Industrial (intake locations must be provided) <input type="checkbox"/>	
Commercial Supplier (intake locations must be provided) <input type="checkbox"/>		Private (intake locations must be provided) <input checked="" type="checkbox"/>	
Purchase Details			
Start Date:	End Date:	Total Purchase from Source (gal):	Max. daily purchase (gal): 1000000
Supplier intake details:			

**Section III(d) - Lake/Reservoir Water Source (to be completed for each lake/reservoir)**

Lake/Reservoir Name:			
Location (decimal degrees, NAD 83)			
Latitude:	Longitude	County:	
Landowner name and address:			
Permission to withdraw obtained from owner: Yes <input type="checkbox"/> No <input type="checkbox"/>	Minimum release (cfs):		
Withdrawal Details			
Start Date:	End Date:	Total Withdrawal from Source (gal):	Max. Pump Rate (gpm):

**RECEIVED**  
**Office of Oil and Gas**  
APR 12 2013  
**Department of Environmental Protection**

**Section III(c) - Purchased Water Source (to be completed for each water supplier, print additional pages as necessary)**

Supplier Name and Contact Information: Mr. Clifford E. Smith Solo Construction, LLC PO Box 544 St. Marys, WV 26170			
Location(decimal degrees, NAD 83)			
Latitude: 39.399094	Longitude: -81.185548	County: Pleasants	
Public Water Provider <input type="checkbox"/>	Waste Water Treatment Plant <input type="checkbox"/>	Industrial (intake locations must be provided) <input checked="" type="checkbox"/>	
Commercial Supplier (intake locations must be provided) <input type="checkbox"/>		Private (intake locations must be provided) <input type="checkbox"/>	
Purchase Details			
Start Date:	End Date:	Total Purchase from Source (gal):	Max. daily purchase (gal): 1000000
Supplier intake details: Middle Island Creek - 39.399094 -81.185548			

**Section III(d) - Lake/Reservoir Water Source (to be completed for each lake/reservoir)**

Lake/Reservoir Name:		
Location (decimal degrees, NAD 83)		
Latitude:	Longitude	County:
Landowner name and address:		
Permission to withdraw obtained from owner: Yes <input type="checkbox"/> No <input type="checkbox"/>	Minimum release (cfs):	
Withdrawal Details		
Start Date:	End Date:	Total Withdrawal from Source (gal):
		Max. Pump Rate (gpm):

**RECEIVED**  
**Office of Oil and Gas**  
**APR 12 2013**  
**Department of Environmental Protection**



**Section III(c) - Purchased Water Source (to be completed for each water supplier, print additional pages as necessary)**

Supplier Name and Contact Information: Sun Valley Withdrawal Jeff Sperry, 234 Power Road Salem, WV, 26426			
Location(decimal degrees, NAD 83)			
Latitude: 39.290626	Longitude: -80.518586	County: Harrison	
Public Water Provider <input checked="" type="checkbox"/>	Waste Water Treatment Plant <input type="checkbox"/>	Industrial (intake locations must be provided) <input type="checkbox"/>	
Commercial Supplier (intake locations must be provided) <input type="checkbox"/>		Private (intake locations must be provided) <input type="checkbox"/>	
Purchase Details			
Start Date:	End Date:	Total Purchase from Source (gal):	Max. daily purchase (gal): 200,000
Supplier intake details:			

**Section III(d) - Lake/Reservoir Water Source (to be completed for each lake/reservoir)**

Lake/Reservoir Name:			
Location (decimal degrees, NAD 83)			
Latitude:	Longitude	County:	
Landowner name and address:			
Permission to withdraw obtained from owner: Yes <input type="checkbox"/> No <input type="checkbox"/>		Minimum release (cfs):	
Withdrawal Details			
Start Date:	End Date:	Total Withdrawal from Source (gal):	Max. Pump Rate (gpm):

**RECEIVED**  
**Office of Oil and Gas**  
**APR 12 2013**  
**Department of Environmental Protection**

**Section III(f) - Recycled Frac Water (to be completed for each source, print additional pages as necessary)**

API # of Previous Well (or other descriptor):	Total volume from source (gal):
Date of Water Transfer	
Start Date:	End Date:

API # of Previous Well (or other descriptor):	Total volume from source (gal):
Date of Water Transfer	
Start Date:	End Date:

API # of Previous Well (or other descriptor):	Total volume from source (gal):
Date of Water Transfer	
Start Date:	End Date:

API # of Previous Well (or other descriptor):	Total volume from source (gal):
Date of Water Transfer	
Start Date:	End Date:

API # of Previous Well (or other descriptor):	Total volume from source (gal):
Date of Water Transfer	
Start Date:	End Date:

**RECEIVED**  
**Office of Oil and Gas**

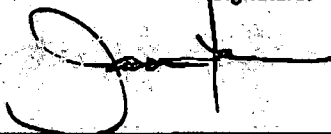
**APR 12 2013**

**WV Department of  
Environmental Protection**

**Section VI - Operator Comments**

--

**Section VII - Plan Reviewed By**

DEP Office Use only		
API# 017-FWC-00009		
Name: Jason Harmon	Signature: 	Date: 5/10/13
Comments		

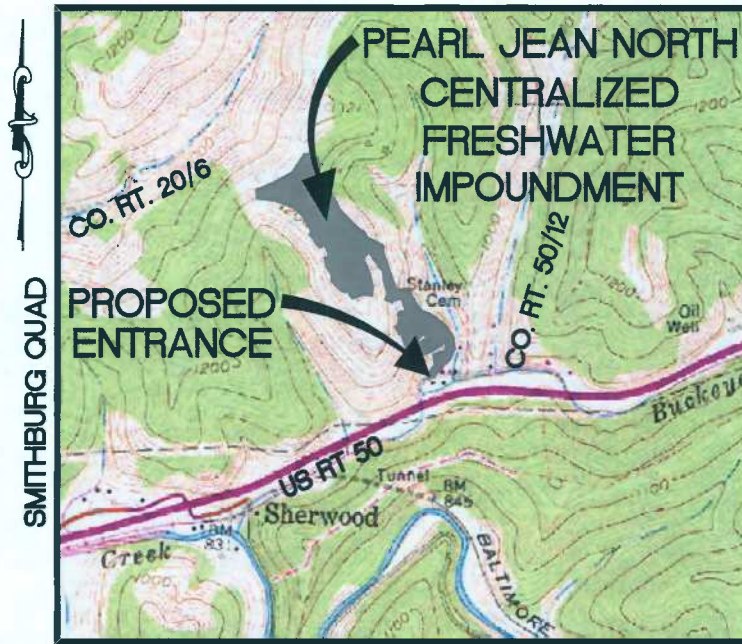
**RECEIVED**  
**Office of Oil and Gas**

APR 12 2013

WV Department of  
Environmental Protection

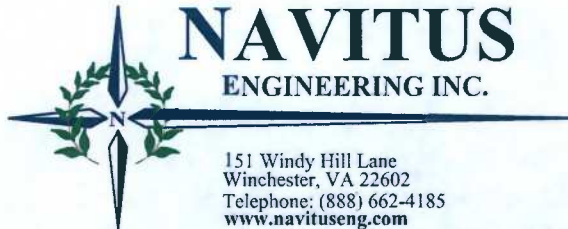
**MAINTENANCE, MONITORING, AND  
EMERGENCY ACTION PLAN  
PEARL JEAN NORTH  
CENTRALIZED FRESHWATER IMPOUNDMENT**

ID# \_\_\_\_\_



VICINITY MAP

1" = 2,000'



Prepared For:

Engineering ◀ Survey ◀ Environmental ◀ GIS



981 East Washington Avenue  
Ellenboro, WV 26346  
(304) 869-3405

Contacts:

Aaron Kunzler, Construction Supervisor  
(405) 227-8344  
Anthony Smith, Field Engineer  
(304) 673-6196  
David Patsy, Land Agent  
(304) 476-6090  
Chris Brown, Water Resources  
(304) 877-8233



Designed By:  
Navitus Engineering, Inc.

Project Manager:  
Cyrus Kump, PE  
[ckump@navituseng.com](mailto:ckump@navituseng.com)

Surface Owner(s):  
Dean R. & Martha A. Pennington

Tax Parcel:  
Map 16 Parcel 21, Map 17 Parcel 28

Location:  
Grant District, Doddridge County,  
West Virginia

Date: April 3, 2013

FN# ANT018

# **TABLE OF CONTENTS**

<b>INTRODUCTION.....</b>	<b>2</b>
Road Map.....	3
Site Plan.....	4
<b>PART I - MONITORING PLAN AND INSPECTION SCHEDULE.....</b>	<b>5</b>
Section A – Normal Conditions:.....	5
Section B – Dangerous Conditions:.....	6
Section C – Standby Alert:.....	7
<b>PART II- EMERGENCY ACTION AND EVACUATION PLAN.....</b>	<b>9</b>
Section A - Notification of Agencies:.....	9
<b>PART III- POST EVACUATION/ROAD CLOSURE PLAN.....</b>	<b>10</b>
Section A - Should No Failure Occur:.....	10
<b>PART IV - ADMINISTRATION AND RECORD KEEPING.....</b>	<b>11</b>
Section A - Distribution:.....	11
Section B – Maintenance Plan:.....	12
Section C – Inspection Record.....	13
<b>PART V – HAZARD EVALUATION AND BREACH CALCULATIONS.....</b>	<b>14</b>
Section A - Introduction.....	14
<b>A.1. Background.....</b>	<b>14</b>
Section B - Hydrologic and Hydraulic Analysis.....	16
<b>B.1. General.....</b>	<b>16</b>
<b>B.2. Base Map.....</b>	<b>16</b>
<b>B.3. Hydrologic Analysis.....</b>	<b>16</b>
<b>B.4. Hydraulic Analysis.....</b>	<b>17</b>
<b>B.5. Results.....</b>	<b>17</b>
Section C - Results.....	18
<b>C.1. 100 year/24 hour Design Storm Routing.....</b>	<b>18</b>
<b>C.2. 100 year/24 hour Design Storm Routing with Breach.....</b>	<b>18</b>
<b>C.3. Summary of Results.....</b>	<b>18</b>
<b>C.4. Reach Length Analysis.....</b>	<b>18</b>
<b>PART VI – EVACUATION PLAN AND PROCEDURES.....</b>	<b>19</b>
Section A – Evacuation Plan.....	19
Section B – Road Closure Procedures.....	19
<b>APPENDICES.....</b>	<b>20</b>
Appendix A - Site Maps.....	20
Appendix B - Residence and Neighboring Property Survey.....	21
Appendix C- Road Closure and Detour Plans.....	22

## **Site Plan**



## **PART I - MONITORING PLAN AND INSPECTION SCHEDULE**

### **Section A – Normal Conditions:**

During initial filling of the impoundment, visual inspection of the surrounding embankment slopes will be performed by field personnel for every 2 feet of depth increase or every 3 hours of time lapse until the impoundment is full to storage depth, providing 2 feet of freeboard. Once the impoundment is full it will be visually observed by field personnel once every 12 hours for the first week of operation. Following the first week of operation normal inspection frequency shall follow the requirements of W. Va Code §35-4-21 and consist of inspections at a minimum of once every two weeks under normal weather conditions.

<i><b>Action</b></i>	<i><b>Responsibility</b></i>	
	Primary Person	Alternate Person
1. Inspect biweekly (once every other week) as appropriate to the condition of the impoundment. If a serious problem is found proceed immediately to Section B or C as appropriate. Inspections shall include the following:	Eli Wagoner PH: 304-622-3842 Cell: 304-476-9770	Chris Brown PH: 304-622-3842 Cell: 304-877-8233
<ul style="list-style-type: none"> <li>• Inspect the condition of the exposed / visible geo-membrane liner for deterioration and potential weakening.</li> </ul>	Eli Wagoner PH: 304-622-3842 Cell: 304-476-9770	Chris Brown PH: 304-622-3842 Cell: 304-877-8233
<ul style="list-style-type: none"> <li>• Verify the water level is consistent with the scheduled input and withdrawal of water.</li> </ul>	Dusty Wood PH: 304-622-3842 Cell: 817-771-1436	Chris Brown PH: 304-622-3842 Cell: 304-877-8233
<ul style="list-style-type: none"> <li>• Verify embankments show no signs of movement or instability.</li> </ul>	Eli Wagoner PH: 304-622-3842 Cell: 304-476-9770	Dusty Wood PH: 304-622-3842 Cell: 817-771-1436
<ul style="list-style-type: none"> <li>• Remove debris (tree branches, leaves, trash, etc.) from the impoundment area.</li> </ul>	Eli Wagoner PH: 304-622-3842 Cell: 304-476-9770	Dusty Wood PH: 304-622-3842 Cell: 817-771-1436
<ul style="list-style-type: none"> <li>• Verify the integrity of the security fence and gate.</li> </ul>	Eli Wagoner PH: 304-622-3842 Cell: 304-476-9770	Chris Brown PH: 304-622-3842 Cell: 304-877-8233
<ul style="list-style-type: none"> <li>• Inspect the inflow and outflow pumping systems for degradation to the geomembrane liner and / or berm.</li> </ul>	Chris Brown PH: 304-622-3842 Cell: 304-877-8233	Eli Wagoner PH: 304-622-3842 Cell: 304-476-9770
<ul style="list-style-type: none"> <li>• Look for signs of erosion along the entire face of the berm.</li> </ul>	Eli Wagoner PH: 304-622-3842 Cell: 304-476-9770	Dusty Wood PH: 304-622-3842 Cell: 817-771-1436
<ul style="list-style-type: none"> <li>• Check for potential seeps or piping through the berm.</li> </ul>	Eli Wagoner PH: 304-622-3842 Cell: 304-476-9770	Dusty Wood PH: 304-622-3842 Cell: 817-771-1436
<ul style="list-style-type: none"> <li>• Other:</li> </ul>	Aaron T Kunzler Cell: 405-227-8344	Chris Brown PH: 304-622-3842 Cell: 304-877-8233



## **Section B – Dangerous Conditions:**

The following monitoring and inspection schedule will be used for heavy or extended rainfall, flash flood warnings, earthquake, snow-melt, or serious new problems found under normal conditions such as slips, sinkholes, or piping. Inspection will occur within 24 hours of a heavy rain event, defined as two (2) inches of rain or more in a six (6) hour period. If a problem is observed which could lead to failure, proceed immediately to Section C.

Occurrence of an earthquake of sufficient magnitude to cause structural damage to buildings or property in the general area of the impoundment shall be considered an "adverse condition". Damage from an earthquake may be internal to the impoundment and problems may not appear for days or weeks after the event. The impoundment shall be inspected immediately after the quake and daily for several weeks thereafter. Attention should be directed to looking for cracks, slips, new wet or seepage areas and leakage, both on the face of the berm and in the natural ground areas downstream.

If possible, the impoundment water level shall be decreased prior to forecast extended rainfall or immediately after concerns are observed.

<i><b>Action</b></i>	<i><b>Responsibility</b></i>	
	<b>Primary Person</b>	<b>Alternate Person</b>
1. Adverse conditions inspections shall be performed daily or more often as necessary and shall include the following:	Eli Wagoner PH: 304-622-3842 Cell: 304-476-9770	Chris Brown PH: 304-622-3842 Cell: 304-877-8233
<ul style="list-style-type: none"> <li>Inspect the condition of the exposed / visible geo-membrane liner for deterioration and potential weakening.</li> </ul>	Eli Wagoner PH: 304-622-3842 Cell: 304-476-9770	Chris Brown PH: 304-622-3842 Cell: 304-877-8233
<ul style="list-style-type: none"> <li>Verify the water level is consistent with the scheduled input and withdrawal of water.</li> </ul>	Eli Wagoner PH: 304-622-3842 Cell: 304-476-9770	Dusty Wood PH: 304-622-3842 Cell: 817-771-1436
<ul style="list-style-type: none"> <li>Verify embankments show no signs of movement or instability.</li> </ul>	Aaron T Kunzler Cell: 405-227-8344	Eli Wagoner PH: 304-622-3842 Cell: 304-476-9770
<ul style="list-style-type: none"> <li>Remove debris (tree branches, leaves, trash, etc.) from the impoundment area.</li> </ul>	Aaron T Kunzler Cell: 405-227-8344	Eli Wagoner PH: 304-622-3842 Cell: 304-476-9770
<ul style="list-style-type: none"> <li>Verify the integrity of the security fence and gate.</li> </ul>	Eli Wagoner PH: 304-622-3842 Cell: 304-476-9770	Chris Brown PH: 304-622-3842 Cell: 304-877-8233
<ul style="list-style-type: none"> <li>Inspect the integrity of surface berms and surface runoff water to ensure no uncontrolled or excessive erosion.</li> </ul>	Eli Wagoner PH: 304-622-3842 Cell: 304-476-9770	Chris Brown PH: 304-622-3842 Cell: 304-877-8233
<ul style="list-style-type: none"> <li>Inspect surface berms and up gradient drainage, ensure no surface water flow into impoundment.</li> </ul>	Eli Wagoner PH: 304-622-3842 Cell: 304-476-9770	Chris Brown PH: 304-622-3842 Cell: 304-877-8233
<ul style="list-style-type: none"> <li>Inspect the inflow and outflow pumping systems for degradation to the geomembrane liner and / or berm.</li> </ul>	Dusty Wood PH: 304-622-3842 Cell: 817-771-1436	Eli Wagoner PH: 304-622-3842 Cell: 304-476-9770
<ul style="list-style-type: none"> <li>Look for signs of erosion along the entire face of the berm.</li> </ul>	Eli Wagoner PH: 304-622-3842 Cell: 304-476-9770	Chris Brown PH: 304-622-3842 Cell: 304-877-8233
<ul style="list-style-type: none"> <li>Check for potential seeps or piping through the berm.</li> </ul>	Eli Wagoner PH: 304-622-3842 Cell: 304-476-9770	Chris Brown PH: 304-622-3842 Cell: 304-877-8233
2. If problem is observed which could lead to failure, proceed immediately to Section C	Eli Wagoner PH: 304-622-3842 Cell: 304-476-9770	Dusty Wood PH: 304-622-3842 Cell: 817-771-1436

**Section C – Standby Alert:**

The following procedure will be used when the condition of impoundment has deteriorated and has been determined to be threatening to the integrity of structure, or the water surface rises to the predetermined critical level of 1 foot above freeboard elevations.

If possible, the impoundment water level shall be decreased as soon as possible after standby alert concerns are observed. The impoundment shall be drawn down to freeboard elevations.

<i>Action</i>	<i>Responsibility</i>	
	Primary Person	Alternate Person
1. Constant surveillance; decrease impoundment or pit volume, if possible.	Dusty Wood PH: 304-622-3842 Cell: 817-771-1436	Eli Wagoner PH: 304-622-3842 Cell: 304-476-9770
• Monitor the surface elevation of the water and the 2 foot of freeboard.	Dusty Wood PH: 304-622-3842 Cell: 817-771-1436	Eli Wagoner PH: 304-622-3842 Cell: 304-476-9770
• Inspect the condition of the exposed / visible geo-membrane liner for deterioration and potential weakening	Dusty Wood PH: 304-622-3842 Cell: 817-771-1436	Eli Wagoner PH: 304-622-3842 Cell: 304-476-9770
• Look for signs of erosion along the entire face of the berm.	Eli Wagoner PH: 304-622-3842 Cell: 304-476-9770	Chris Brown PH: 304-622-3842 Cell: 304-877-8233
• Inspect the inflow and outflow pumping systems for degradation to the geomembrane liner and / or berm.	Dusty Wood PH: 304-622-3842 Cell: 817-771-1436	Eli Wagoner PH: 304-622-3842 Cell: 304-476-9770
• Check for potential seeps or piping through the berm.	Eli Wagoner PH: 304-622-3842 Cell: 304-476-9770	Dusty Wood PH: 304-622-3842 Cell: 817-771-1436
2. Alert potential affect parties of the danger.	Eli Wagoner PH: 304-622-3842 Cell: 304-476-9770	Chris Brown PH: 304-622-3842 Cell: 304-877-8233

Notify agencies according to checklist in the following tables:

<b>AGENCIES TO BE NOTIFIED</b>		
<u>Check</u>	<u>When Completed</u>	<u>Phone</u>
___	Local 911	911
___	WVDEP Office of Oil and Gas	304-926-0450
___	Local Oil and Gas Inspector - Douglas Newlon	304-932-8049
___	Spill Reporting Number (if waste impoundment release)	1-800-642-3074
___	Doddridge County Office of Emergency Services (OES)	1-800-873-1391

## AGENCY NOTIFICATION CHECKLIST

### Check When Completed

- Identify yourself
- Refer to the Impoundments as the Pearl Jean North Centralized Freshwater Impoundment
- State WVDEP Oil and Gas Impoundment ID # \_\_\_\_\_.
- Advise the person that you are calling as required by the emergency action plan.
- State the condition of the impoundment.
- State that a standby alert has been declared.
- Advise the person contacted of any requested assistance or action.
- Describe the conditions that warranted the standby alert.
- Describe the immediate danger and risks to surrounding people and property.
- Describe the immediate actions being conducted to avert further danger.
- Answer any questions.
- Document the time and with whom you speak at the notified agencies (Name / title)

**If failure of the structure is deemed to be imminent, immediately begin notification and evaluation procedures, as described in Part II, Emergency and Evacuation Plan**

## **PART II- EMERGENCY ACTION AND EVACUATION PLAN**

### **Section A - Notification of Agencies:**

Notify the following agencies of an evacuation notice if not already on-site.

<b>AGENCIES TO BE NOTIFIED</b>		
<u>Check When Completed</u>		<u>Phone</u>
<input type="checkbox"/>	Local 911	911
<input type="checkbox"/>	WVDEP Office of Oil and Gas	304-926-0450
<input type="checkbox"/>	Local Oil and Gas Inspector - Douglas Newlon	304-932-8049
<input type="checkbox"/>	Spill Reporting Number (if waste impoundment release)	1-800-642-3074
<input type="checkbox"/>	Doddridge County Office of Emergency Services (OES)	1-800-873-1391

### **Section B – Emergency Evacuation**

Working with emergency response personnel and any available company representatives, begin emergency notification of potentially affected surrounding people, residences and businesses, with the objective of moving all people out of harm's way.

Based on Hazard Evaluation and survey, contact the people and organizations on downstream of impoundment that may be impacted by a failure. Inform them of the potential for impending danger and assist them with evacuation to a safe location, if needed.

## **PART III- POST EVACUATION/ROAD CLOSURE PLAN**

### **Section A - Should No Failure Occur:**

#### ACTION

1. Notify agencies according on checklist below to cancel evacuation order (if not already onsite).

<b>AGENCIES TO BE NOTIFIED</b>		
<u>Check When Completed</u>		<u>Phone</u>
_____	Local 911	911
_____	WVDEP Office of Oil and Gas	304-926-0450
_____	Local Oil and Gas Inspector - Douglas Newlon	304-932-8049
_____	Spill Reporting Number (if waste impoundment release)	1-304-842-1550
_____	West Virginia Department of Highways, County Supervisor	1-304-842-1550
_____	Doddridge County Office of Emergency Services (OES)	1-800-873-1391

2. Inform affected parties that the emergency has past and it is safe to return.
3. Immediately begin any efforts to stabilize the structure and/or reduce water volume. An engineering analysis and evaluation will begin to determine root cause of problems and corrective actions.

**See Appendix C for Road Closure and Detour Plans.**

## **PART IV - ADMINISTRATION AND RECORD KEEPING**

Antero Resources will distribute copies of the Monitoring and Emergency Plan for the Pearl Jean North Centralized Freshwater Impoundment within fifteen days (15) after receipt of the WVDEP Office of Oil and Gas approval to the persons named in the distribution list below.

*The undersigned states that he/she will distribute a copy of the Monitoring and Emergency Plan for the Pearl Jean North Centralized Freshwater Impoundment within fifteen days of the WVDEP Office of Oil and Gas approval to the persons named in the Section A – Distribution List below.*

<b>Name</b> (Amanda Fernley)	<b>Title</b>	<b>Date</b>
------------------------------	--------------	-------------

### **Section A - Distribution:**

Names and Addresses of all persons or agencies retaining a copy of this plan:

<b>NAME</b>	<b>COMPLETE MAILING ADDRESS</b>
Gene Smith Regulatory Compliance Manager 304-926-0452 ext. 1652	DEP Division of Oil and Gas 601 57 <sup>th</sup> Street, SE Charleston, WV 25304-2345
Douglas Newlon Local Oil and Gas Inspector 304-932-8049, 304-573-5834	DEP Division of Oil and Gas 4060 Dutchman Road Macfarlan, WV 26248
Shirley Williams 304-873-2631 Fax: 304-873-1840	Doddridge County Commission 118 East Court Street West Union, WV 26456
W.C. Underwood Jr. Doddridge County Sheriff 304-873-1944	Doddridge County Sheriff PO Box 219 West Union, WV 26456
Greg Phillips County Supervisor 304-842-1550	West Virginia Department of Highways I-79 & Meadowbrook Road Clarksburg, WV 26302-2570
Chris Brown Water Resources 304-877-8233	Antero Resources 175-D Elk Creek Road Mt. Clare, WV 26408
Eli Wagoner, PE Environmental 304-476-9770	Antero Resources 175-D Elk Creek Road Mt. Clare, WV 26408
Pat Heaster Director 304-873-1391	Doddridge County Office of Emergency Services 118 E. Court St. Room 102 West Union, WV 26415

**Section B – Maintenance Plan:**

**MAINTENANCE PLAN FOR \_\_\_\_\_ Impoundment ID# \_\_\_\_\_ 20\_\_**

Type of Maintenance	JAN	FEB	MAR	APR	MAY	JUN	JUL	AUG	SEP	OCT	NOV	DEC
Monitoring Plan Inspection	X	X	X	X	X	X	X	X	X	X	X	X
Bi-weekly Facility Inspection	X	X	X	X	X	X	X	X	X	X	X	X
Monthly Inspection Certification Submitted to Office of Oil and Gas	X	X	X	X	X	X	X	X	X	X	X	X
Embankment												
Mow Embankment					X		X		X			
Repair Erosion Gullies			X*	X*	X*	X*	X*	X*	X*	X*	X*	
Revegetate Bare Areas				X			X			X		
Clean Embankment Outlet Pipe			X*	X*	X*	X*	X*	X*	X*	X*	X*	
Repair All Animal Burrows			X*	X*	X*	X*	X*	X*	X*	X*	X*	
Remove Trees/Brush				X			X			X		
Inspect perimeter fencing, ensure access is restricted	X	X	X	X	X	X	X	X	X	X	X	X
Access Gate with Emergency Lifeline	X	X	X	X	X	X	X	X	X	X	X	X

**Comments:**

\* After inspection repair/replace as needed

---



---



---





## **PART V - HAZARD EVALUATION AND BREACH CALCULATIONS**

### **Section A - Introduction**

#### **A.1. Background**

Navitus Engineering, Inc. (Navitus) has performed this Impoundment Breach Analysis for the Pearl Jean North Centralized Freshwater Impoundment as requested by Antero Resources Appalachian Corporation (Antero). In order to construct and operate the facility, a Certificate of Approval for the Centralized Impoundment is required to be obtained through the West Virginia Department of Environmental Protection (WVDEP) Office of Oil and Gas. The centralized impoundment application requires that the proposed impoundment be analyzed in order to determine if a potential impoundment breach would cause serious damage to property, inhabited structures, or roads. Per WVDEP nomenclature, the facility will be referred to as a centralized freshwater impoundment since there is no potential for waste materials to be present. The breach study was completed in accordance with the WVDEP Division of Water Resources, Title 47 Series 34, Dam Safety Rule, dated June 1, 2009. The WVDEP Division of Water Resources Dam Safety Rule suggests the centralized freshwater impoundment is not classified as a dam. A Hydrologic and Hydraulic analysis was performed for the 100-year/24-hour design storm. The downstream reach length was established as the point at which the design storm breach water surface elevation (WSE) is attenuated to have less than 1 foot of impact when compared to the design storm WSE.

The proposed impoundment is located in Doddridge County, West Virginia about 3.4 miles east of Smithburg, West Virginia along the north side of US Rte. 50. The centralized freshwater impoundment is located on a ridgeline and has no contributing offsite drainage area. US Rte. 50 is located about 2200 feet south of the proposed centralized freshwater impoundment. A site location map depicting the proposed impoundment location in relation to US Rte. 50, Buckeye Run and all associated tributaries is provided in Appendix A.

To qualify for the WVDEP Oil and Gas Certification of Approval, the Centralized Impoundment structure shall satisfy the WVDEP Dam Safety requirements. WVDEP Dam Safety definition of an impoundment is as follows:

- An embankment height of 25 feet above natural streambed at the downstream toe to the impoundment crest and impound 15 or more acre-feet of water volume; or
- An embankment rise of 6 feet from natural streambed or at downstream toe to embankment crest and impound 50 or more acre-feet.

Based on the WVDEP Dam Safety Rule, the impoundment height is defined as the vertical height from natural streambed at downstream toe to crest of impoundment. The proposed Pearl

Jean North Centralized Freshwater Impoundment is partially incised; therefore the maximum impoundment height of 48.0 feet was measured from the existing ground to impoundment crest.

The impoundment is located along a ridgeline and has a west breach scenario. The impoundment height was measured utilizing the crest elevation to the existing grade elevation with 24 inch toe bench/key in. The west breach impoundment height is 12.0 feet measured from crest elevation of 1220 to existing ground minus key in elevation equal to 1208.

The total impoundment storage volume is approximately 16.28 acre-feet at the crest elevation, the incised volume below the existing grade level is 3.08 acre-feet. No discharge or outlet structures are proposed for the impoundment. The maximum operating water surface elevation (WSE) of the impoundment is 1218, which will provide 2 feet of freeboard. As such, the impoundment appears to be non-jurisdictional under the Dam Safety Rule (WV Code 47-CSR34).

## **Section B - Hydrologic and Hydraulic Analysis**

### **B.1. General**

A hydrologic and hydraulic analysis was prepared to determine if a potential impoundment breach would inundate existing structures or roadways. For this study, two separate scenarios were analyzed:

1. The 100-year/24-hour storm event without impoundment breach
2. The 100-year/24-hour event with impoundment breach

### **B.2. Base Map**

The Site Maps (Appendix A) depict the topography used for the breach study. Topography was derived from aerial mapped 2-foot interval topography by Blue Mountain Aerial Mapping in March 2012 and 10-foot interval topography converted from 3 meter West Virginia GIS Technical Center DEM data. Stream locations were mapped by GAI Consultants. This topographic information and stream data were utilized for the base mapping.

### **B.3. Hydrologic Analysis**

The hydrologic analysis utilized USDA soil surveys for computation of drainage shed curve numbers, aerial topography and 3 meter West Virginia GIS Technical Center DEM to determine the drainage area(s) and time of concentration path(s). The peak 100-year discharge within the inundation area was determined through TR-55 SCS methodology. Time of concentration paths were calculated utilizing the SCS lag method. The hydrologic calculations for the drainage area were performed using HEC-HMS. The breach was modeled within HEC-HMS utilizing a reservoir and dam breach scenario. The breach utilized a specific time trigger, with the time set at the peak hour found at the downstream junction of Buckeye Run. With the peak times matching, this created the worst case scenario for downstream drainage sheds. The breach width and development time were modeled using Froelich's Dam Break Predictor Equations. The calculated peak flows for the upstream sections to downstream sections are found in the *Miscellaneous Attachments and Design Computations*. The table below is a summary of the drainage computations for the breach flows.

<b>Stream</b>	<b>Computed Flow (cfs)</b>	<b>Average Breach Width (ft)</b>	<b>Time of Failure (hrs)</b>
West Breach	984.2	33.9	0.21

The proposed Pearl Jean North Centralized Freshwater Impoundment will be constructed by a combination of excavation and the construction of fill embankments. The proposed fill embankments will be constructed on the east and west sides of the facility. The impoundment height of the west side will be 12 feet.

The potential breach from the west embankment of the proposed impoundment would travel in a southwesterly direction for approximately 2,800 feet before flowing into Buckeye Run.

#### B.4. Hydraulic Analysis

HEC-RAS was used to analyze the downstream flood wave and model the potential impoundment breach. The base map data was utilized to generate the geometry of each cross section. The cross sections were employed at significant changes in site features. This includes major bends in the stream channel, areas of major contraction and expansion of the floodplain area, upstream and downstream of existing culverts, and at building obstructions (cross sections were compiled using Aerial Mapping by Blue Mountain Aerial Mapping and 10-foot interval topography converted from 3 meter West Virginia GIS Technical Center DEM data). The Overall Site Map (Appendix A) depicts the locations of the critical sections used for the breach study.

A Steady flow analysis was utilized to model the flood wave, and calculate base flood elevations at critical determined cross sections downstream of the breach analysis based upon Hydrologic Data from HEC-HMS. Downstream reach boundary conditions were modeled utilizing the slope of the normal water surface. The proposed site is located in Flood Zone X, where Buckeye Run intersects with Buckeye Creek is Flood Zone AE per FEMA Flood Map #54017C0145C. Two models were prepared: 1. 100 Year-24 Hour Design Storm, 2. 100 Year-24 Hour Design Storm with Breach. The breach flows were modeled in flow change locations. Breach flows were determined using manning's equation, with maximum volumes generated at the incised volume of the breach location. See the *Miscellaneous Attachments and Design Computations* for complete Drainage Computations.

The channel and overbank areas were assigned manning's n-values based on photographs and close inspection of existing aerial photography. The chart below describes the manning's n values used in this study taken from Table 3-1 of the HEC-RAS River Analysis System Hydraulic Reference Manual Version 4.1, January 2010.

Manning's n value	Description	Portion Used
.1	Heavy stand of timber, few down trees, little undergrowth, flow below branches	Floodplains
.035	Clean, straight, full, no rifts or deep pools with more stones and weeds	Main Channel
.035	High grass	Floodplains
.06	Light brush and trees, in summer	Floodplains

#### B.5. Results

A summary of the hydrologic and hydraulic calculations is provided in the *Miscellaneous Attachments and Design Computations*. Further information from the HEC-RAS or HEC-HMS analysis can be provided upon request.

## **Section C - Results**

### **C.1. 100 year/24 hour Design Storm Routing**

During the 100-year/24-hour design storm, no flooding is expected to roads or dwelling structures along the drainage shed. The proposed drainage model is located in Flood Zone "X" and "AE" per FEMA Flood Map #54017C0145C. Structure #4 is located within the limits of the defined Flood Zone "AE".

### **C.2. 100 year/24 hour Design Storm Routing with Breach**

Flooding is expected to U.S. Route 50 during the 100-year/24-hour design storm with an impoundment breach. Flooding occurs to U.S. Route 50 during the West Breach Scenario between sections 12+41.605 and 10+16.820. See Part VI for evacuation procedures and necessary road closure measures and signage required in the case of a breach of the impoundment.

### **C.3. Summary of Results**

For each of the evaluated scenarios the summary of results included with the *Miscellaneous Attachments and Design Computations* provides the following information:

- Peak water surface elevations for the West Breach at Section 12+41.605 at U.S. Route 50

Based on the results of the analysis, flooding on U.S. Route 50 will occur under the 100 year flood West Breach scenario near the stations listed above. A summary table of the hydrologic and hydraulic calculations is provided in the *Miscellaneous Attachments and Design Computations*.

### **C.4. Reach Length Analysis**

The HEC-RAS summary results provide the WSEs at the critical downstream sections resulting from the various scenarios that were evaluated. Comparing the results of the no breach versus impoundment breach scenario for the 100-year storm, the resulting WSE in section -2+07.558 of Buckeye Run is less than 1-foot of elevation between the 100-year/24-hour design and the breach scenario. Therefore, the station represents the downstream terminus of the flood wave routing, and any further downstream impacts from the breach are a negligible threat to human health or the environment.

## **PART VI – EVACUATION PLAN AND PROCEDURES**

### **Section A – Evacuation Plan**

The results of this analysis are based on the "worst case scenario" for the breach events, or the 100 year/24 hour Design Storm Routing with Breach. All breach events that occur in **any** event less than that of the aforementioned design are required to follow the same procedures set forth in the sections below.

### **Section B – Road Closure Procedures**

Based on the results of the analysis, flooding on U.S. Route 50 will occur under the 100-year/24-hour West Breach design scenario. The road will be closed and Law Enforcement and Emergency personnel immediately contacted. Detour routes are shown in the Road Closure and Detour Plans found in Appendix C, however, these Routes should be confirmed with Law Enforcement and Emergency personnel before proceeding with detour.

All traffic control devices shall be placed in accordance with the West Virginia Manual on Temporary Traffic Control for Streets and Highways, March 2006. The closure of County or State Routes shall only occur after authorization by West Virginia Department of Highways. A WVDOH representative shall be onsite during closure activities. All signage along the detour route shall be in accordance with the West Virginia Manual on Temporary Traffic Control for Streets and Highways, March 2006. A WVDOH representative may require other traffic control signs as necessary.

# **APPENDICES**

## **Appendix A - Site Maps**

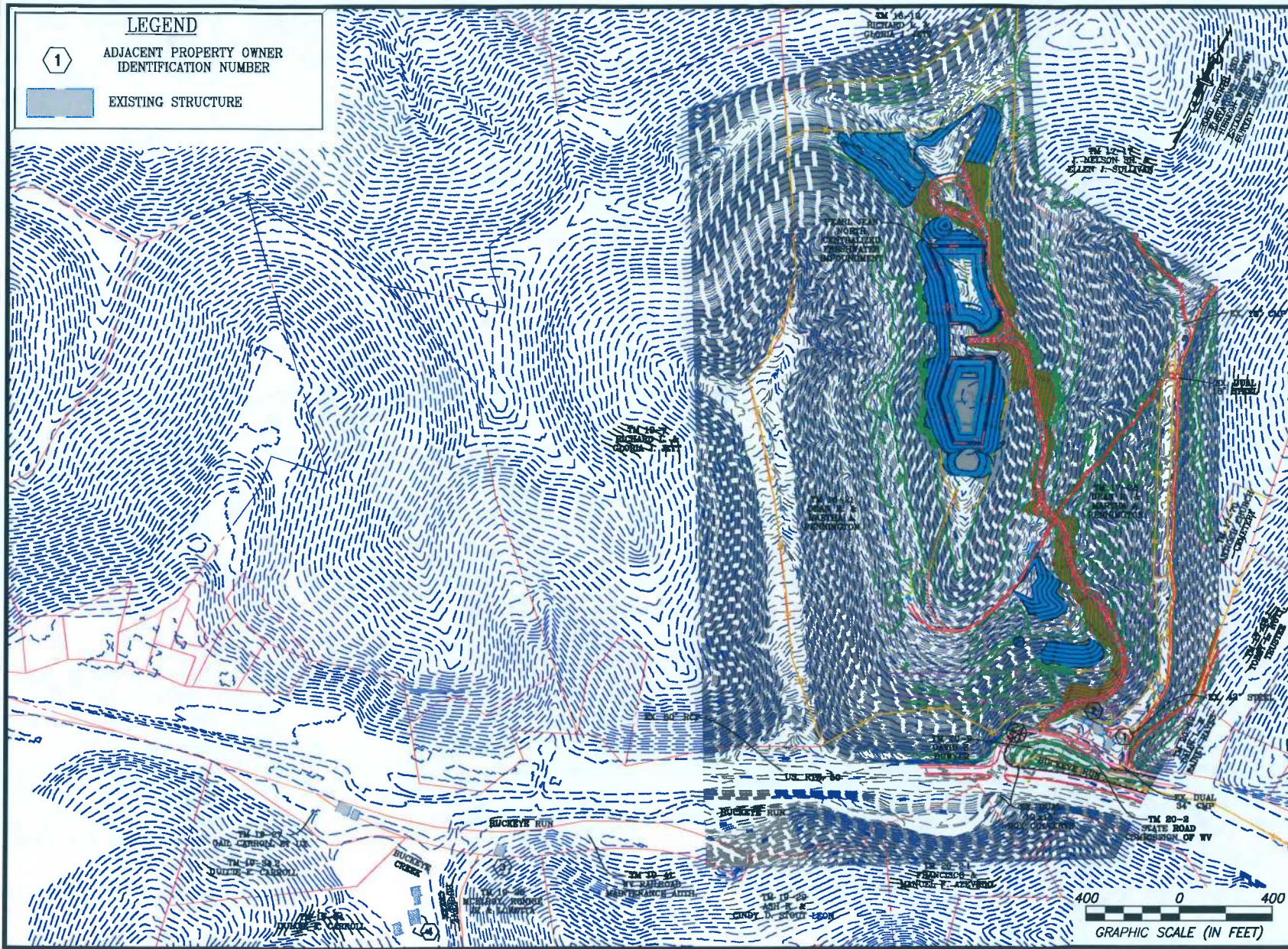
**LEGEND**

1

ADJACENT PROPERTY OWNER  
IDENTIFICATION NUMBER



EXISTING STRUCTURE



**NAVITUS**  
ENGINEERING INC.

151 Windy Hill Lane  
Wachsport, Virginia 25902  
Telephone: (888) 662-4185  
www.navituseng.com

Engineering Survey Environmental GIS

CIRUS B. KUMP  
REGISTERED  
1978  
STATE OF  
WEST VIRGINIA  
PROFESSIONAL ENGINEER

04/03/2013






**ANTERO**  
RESOURCES

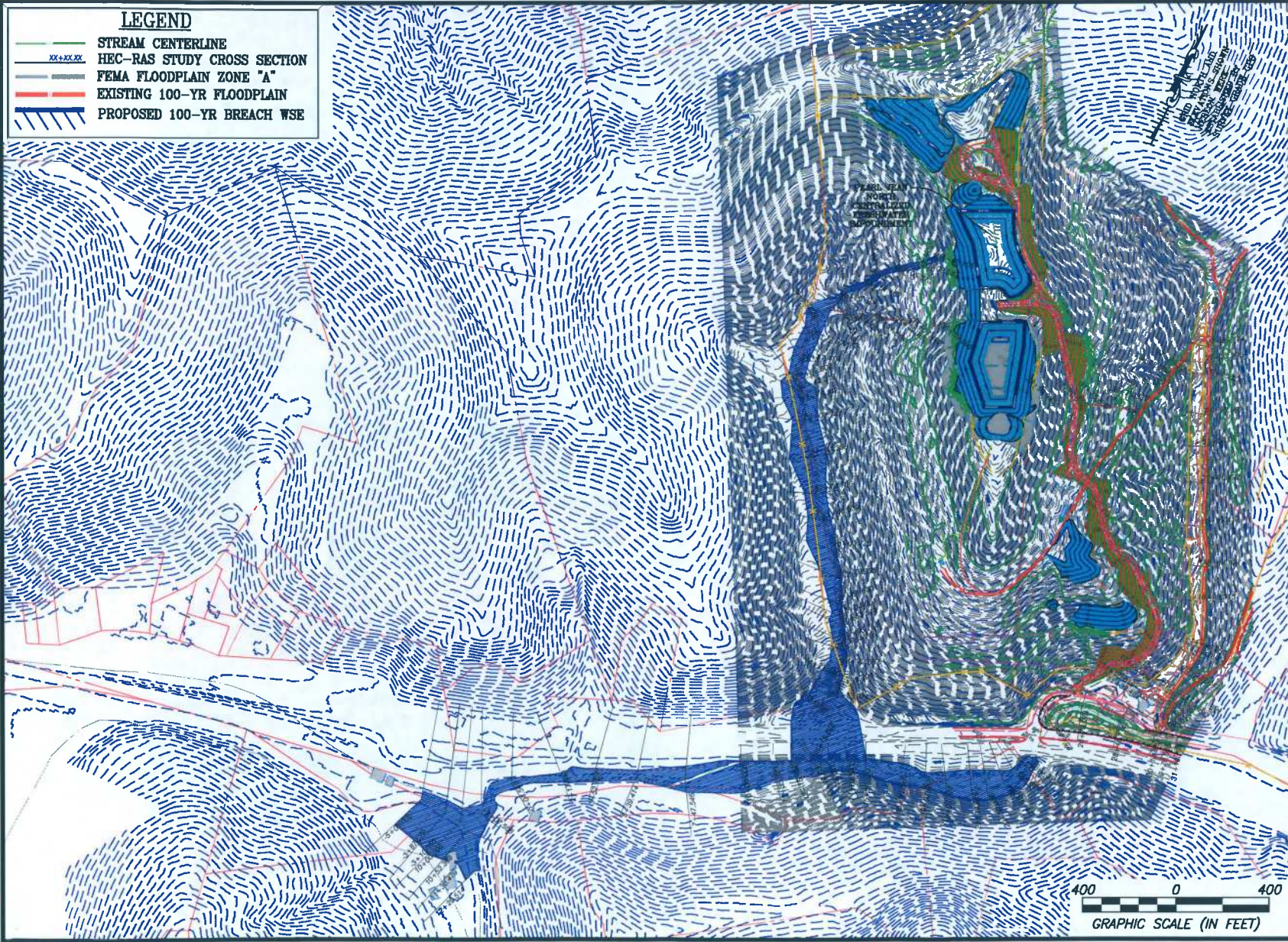
THIS DOCUMENT  
WAS PREPARED  
FOR:  
ANTERO RESOURCES  
APPALACHIAN CORP

OVERALL  
SITE MAP  
**PEARL JEAN NORTH  
CENTRALIZED FRESHWATER  
POND**  
GRANT DISTRICT  
DODDRIDGE COUNTY, WV

SCALE: 1" = 400'  
PEARL JEAN NORTH  
JOB NO. ANTO18  
DATE: 04/03/2013  
SHEET A.1



- LEGEND**
-  STREAM CENTERLINE
  -  HEC-RAS STUDY CROSS SECTION
  -  FEMA FLOODPLAIN ZONE "A"
  -  EXISTING 100-YR FLOODPLAIN
  -  PROPOSED 100-YR BREACH WSE



**NAVITUS**  
ENGINEERING INC.

151 Winding Hill Lane  
Winchester, Virginia 22602  
Telephone: (888) 662-4185  
www.navituseng.com

Engineering Survey Environmental GIS

CYRUS S. KUMAR  
REGISTERED  
1978  
STATE OF  
WEST VIRGINIA  
PROFESSIONAL ENGINEER  
04/03/2013

**ANTERO**  
RESOURCES

THIS DOCUMENT  
WAS PREPARED  
FOR:  
ANTERO RESOURCES  
APPALACHIAN CORP

WEST BREACH ROUTE  
SITE MAP  
**PEARL JEAN NORTH  
CENTRALIZED FRESHWATER  
IMPOUNDMENT**  
GRANT DISTRICT  
DODDRIDGE COUNTY, WV

SCALE: 1" = 400'  
PEARL JEAN NORTH  
JOB NO. ANT018  
DATE: 04/03/2013  
SHEET A.2

**Appendix B - Residence and Neighboring Property Survey**

**PEARL JEAN NORTH CENTRALIZED FRESHWATER IMPOUNDMENT**  
**Appendix B - Residence and Neighboring Property Survey Legend**

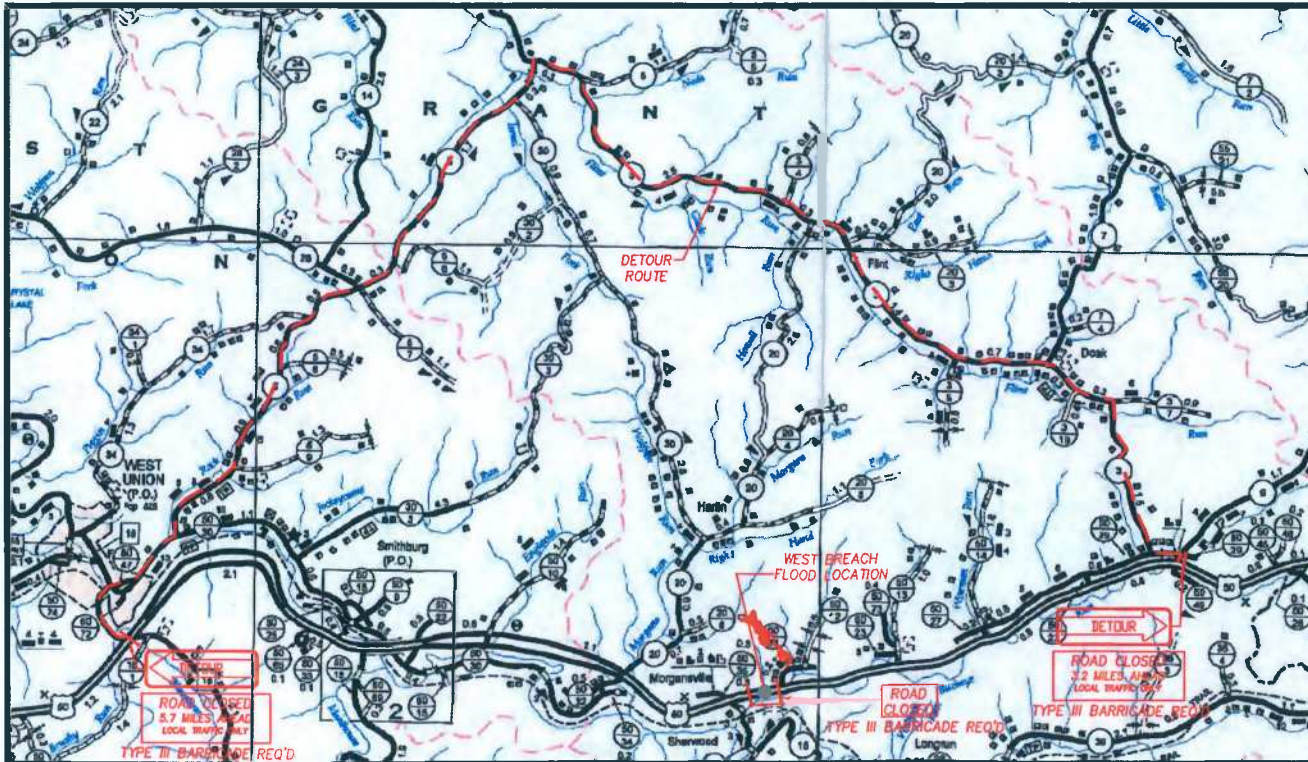
<b>KEY</b>	<b>Tax Map / Parcel No.</b>	<b>PROPERTY OWNER</b>	<b>RESIDENT</b>	<b>RESIDENT ADDRESS</b>	<b>EX 100 YEAR EVENT INUNDATION</b>	<b>WEST BREACH 100 YR INUNDATION</b>	<b>Evacuation Necessary for Breach Alarm</b>
1	16-21	Dean R. & Martha A. Pennington	Paul Layfield Harding	111 Antioch Road Salem, WV 26426	No Effect	No Effect	N
2	16-21	Dean R. & Martha A. Pennington	Mica Ash	101 Antioch Road Salem, WV 26426	No Effect	No Effect	N
3	19-28	Ronnie Jr. & Loretta McElroy		Rt 1 Box 118A West Union, WV 26456	No Effect	No Effect	N
4	19-34	Dulcie F. Carroll	Chris & Susan Carroll	522 Dublin Drive West Union, WV 26456	No Effect	No Effect	N

**Appendix C- Road Closure and Detour Plans**

# PEARL JEAN NORTH CENTRALIZED FRESHWATER IMPOUNDMENT COUNTY RTE. 50 DETOUR PLAN

## GENERAL NOTES:

1. ALL SIGNS ARE TO BE POST MOUNTED IF THE CLOSURE TIME EXCEEDS SEVEN DAYS.
2. FOR NIGHT OPERATION FLASHING LIGHTS SHALL BE INSTALLED ABOVE THE FIRST SIGN ON EACH APPROACH EXCEPT THE ROAD CLOSED SIGN SHALL HAVE FLASHERS AN BOTH ADVANCE SIGNS. (TYPE "B").
3. A ROUTE MARKER DIRECTIONAL ASSEMBLY MAY BE PLACED ON THE FAR LEFT CORNER OF THE INTERSECTION TO AUGMENT OR REPLACE THE ONE SHOWN ON THE NEAR RIGHT CORNER.
4. OTHER SPECIAL DESTINATION SIGNS MAY BE NECESSARY AND SHOULD BE IN ACCORDANCE WITH THE CONTRAST PLANS.
5. ADDITIONAL FLASHING WARNING LIGHTS AND/OR FLAGS MAY BE USED TO CALL ATTENTION TO THE ADVANCE WARNING SIGNS AS NOTED ON THE PLANS, AND/OR AS DIRECTED BY THE WVDOH.



WEST VIRGINIA STATE PLANE  
COORDINATE SYSTEM  
NORTH ZONE, NAD83  
ELEVATION BASED ON NAVD88  
& OPUS POST-PROCESSING

**NAVITUS**  
ENGINEERING INC.



151 Windy Hill Lane  
Winchester, Virginia 27402  
Telephone: (888) 662-4185  
www.navituseng.com

Engineering Survey Environmental GIS



COUNTY RTE. 50  
DETOUR PLAN  
**PEARL JEAN NORTH  
CENTRALIZED FRESHWATER  
IMPOUNDMENT**  
GRANT DISTRICT  
DODDRIDGE COUNTY, WV

SCALE: 1" = 5000'  
PEARL JEAN NORTH  
JOB NO. ANT018  
DATE: 04/03/2013  
SHEET C.1

**Appendix B - Residence and Neighboring Property Survey**

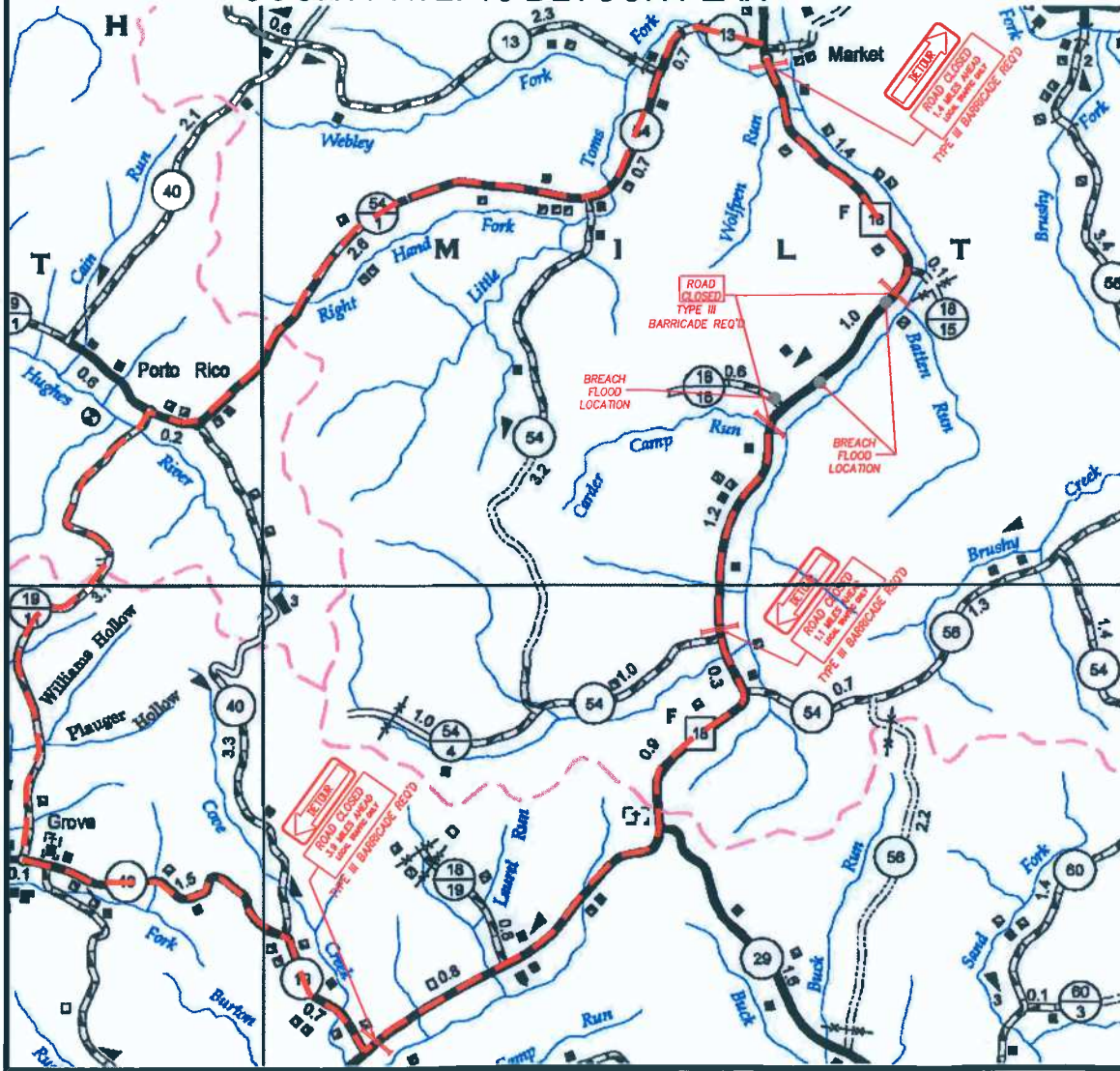
### Residence and Neighboring Property Survey Legend

KEY	PROPERTY OWNER	ADDRESS	EX 100 YEAR EVENT INUNDATION	EAST BREACH 100 YR INUNDATION	WEST BREACH 100 YR INUNDATION	Evacuation Necessary for Breach Alarm
1	Robert G. and Joan C. Conrad & Irene T. Busch	Rt. 1 Box 72 New Milton, WV 26411	Structure is not within 100 YR Flood Event Limits	No Effect	No Effect	N
2	Johnnie & Amye Cline	Box 217 Baisdan, WV 25608	Structure is not within 100 YR Flood Event Limits	No Effect	No Effect	N
3	Ralph L & Deloris L Cox	103 Walnut St. West Union, WV 26456	Structure is not within 100 YR Flood Event Limits	No Effect	No Effect	N

**Appendix C- Road Closure and Detour Plans**



# HINTER HEIRS NORTH CENTRALIZED FRESHWATER IMPOUNDMENT COUNTY RTE. 18 DETOUR PLAN



WEST VIRGINIA STATE PLANE  
COORDINATE SYSTEM  
NORTH ZONE, NAD83  
ELEVATION BASED ON NAVD88  
ESTABLISHED BY SURVEY GRADE GPS  
& OPUS POST-PROCESSING

**GENERAL NOTES:**

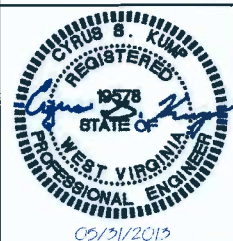
1. ALL SIGNS ARE TO BE POST MOUNTED IF THE CLOSURE TIME EXCEEDS SEVEN DAYS.
2. FOR NIGHT OPERATION FLASHING LIGHTS SHALL BE INSTALLED ABOVE THE FIRST SIGN ON EACH APPROACH EXCEPT THE ROAD CLOSED SIGN SHALL HAVE FLASHERS ON BOTH ADVANCE SIGNS. (TYPE "B").
3. A ROUTE MARKER DIRECTIONAL ASSEMBLY MAY BE PLACED ON THE FAR LEFT CORNER OF THE INTERSECTION TO AUGMENT OR REPLACE THE ONE SHOWN ON THE NEAR RIGHT CORNER.
4. OTHER SPECIAL DESTINATION SIGNS MAY BE NECESSARY AND SHOULD BE IN ACCORDANCE WITH THE CONTRAST PLANS.
5. ADDITIONAL FLASHING WARNING LIGHTS AND/OR FLAGS MAY BE USED TO CALL ATTENTION TO THE ADVANCE WARNING SIGNS AS NOTED ON THE PLANS, AND/OR AS DIRECTED BY THE WVDOH.



**NAVITUS**  
ENGINEERING INC.

151 Waddy Hill Lane  
Winchester, Virginia 22602  
Telephone: (888) 662-4185  
www.navituseg.com

Engineering Survey Environmental GIS



**ANTERO RESOURCES**

THIS DOCUMENT  
WAS PREPARED  
FOR:  
ANTERO RESOURCES  
APPALACHIAN CORP.

COUNTY RTE. 18  
DETOUR PLAN  
**HINTER HEIRS**  
NORTH CENTRALIZED  
FRESHWATER IMPOUNDMENT  
NEW MILTON DISTRICT  
DODDRIDGE COUNTY, WV

SCALE: 1" = 3000'  
HINTER HEIRS  
JOB NO. ANT028  
DATE: 05/31/2013  
SHEET C.1



WEST VIRGINIA DEPARTMENT OF TRANSPORTATION

**Division of Highways**

Earl Ray Tomblin  
Governor

Office of the District Engineer/Manager  
District Four

PO Box 4220 (EXIT 121, I-79) \* Clarksburg, WV 26302 \* 304-842-1550

June 5, 2013

Paul A. Mattox, Jr., P. E.  
Secretary of Transportation /  
Commissioner of Highways

ANTERO RESOURCES APPALACHIAN  
CORPORATION  
175 D ELK CREEK ROAD  
MOUNT CLARE, WV 26408

Dear Applicant:

Your approved copy of Permit Number 04-2013-0394 for a DP - Drilling Permit  
permit type is enclosed. A description of the work is on the permit.

Please contact the District Four office:

**Denise Roncone 304-842-1575**

at least 48 hours in advance of the date you plan to begin work so arrangements can be made to inspect the work authorized  
by the permit.

**Failure to comply will result in cancellation of your permit.**

A copy of this permit is to be available on the job at all times while the work is in progress for inspection by the  
West Virginia Division of Highways' personnel.

Sincerely,

---

District Engineer / District Manager

Permit Supervisor

Initials: TC

Attachments: Yes

Enclosure: No

cc:0409 Charleston Permits

E.E.O/AFFIRMATIVE ACTION EMPLOYER

PERMIT NO. 0420130394

PERMIT TO ENTER UPON, UNDER, OVER OR ACROSS THE STATE ROADS OF THE STATE OF WEST VIRGINIA, AS PROVIDED FOR IN SECTION 6, ARTICLE 16, CHAPTER 17; SECTION 9, ARTICLE 16, CHAPTER 17; SECTION 8, ARTICLE 4, CHAPTER 17, WEST VIRGINIA CODE, 1931, AS AMENDED.

THIS PERMIT, Made this 12th day of April 20 13, between the WEST VIRGINIA DEPARTMENT OF TRANSPORTATION, DIVISION OF HIGHWAYS, a statutory corporation hereinafter called DIVISION and Antero Resources Appalachian Corporation  
Address: 1625 17<sup>th</sup> Street, Denver, CO 80202 Phone No: 303) 357-7310  
hereinafter called APPLICANT.

WITNESSETH

In consideration of the hereinafter set out covenants and in accordance with Section 6, Article 16, Chapter 17; or Section 9, Article 16, Chapter 17; or Section 8, Article 4, Chapter 17, of the Official Code of West Virginia, 1931, as amended, and the rules and regulations promulgated thereunder, APPLICANT does hereby apply to enter

Route Type & No. SLS 50/24 DOH Project No. \_\_\_\_\_ (if applicable);  
at located .06 miles NW of the intersection of SLS 50/24 & US Route 50 Mile Post 0.032  
in Doddridge County, for the purposes hereinafter set forth and in accordance with the plans and specifications which are attached hereto and made a part hereof: To construct and maintain a existing heavy hauling approach for a the Pearl Jean well site. Located on the NW side of SLS 50/24, approximately .06 miles NW of the intersection of SLS 50/24 and US Route 50. Site distance is approximately 320 feet to the East and 215 feet to the West. the Pearl Jean Pad.

APPLICANT further agrees to accept the conditions hereinafter set forth:

1. APPLICANT shall deposit with DIVISION the sum of \$ 1,000,000 in the form of an official, certified or cashier's check, or executed bond with surety satisfactory to DIVISION to cover any damage and inspection costs DIVISION may sustain by reason of the granting of this permit, including any expense incurred in restoring said highway to its original condition or the proper repair of any and all damages that may result within one (1) year from the date of the completion of said work.
2. APPLICANT agrees to reimburse DIVISION for inspection costs as follows:
  - A. For any inspection costs incurred under this permit.
  - B. At \$ \_\_\_\_\_ per linear foot for \_\_\_\_\_ feet of water line installed under this permit
  - C. At \$ \_\_\_\_\_ per linear foot for \_\_\_\_\_ feet of sewer line installed under this permit
3. APPLICANT shall notify DIVISION at least 48 hours in advance of the date the work will begin. Failure to comply will be cause for cancellation of this permit.
4. APPLICANT agrees to protect its employees, equipment and users of the highway at all times in accordance with the current Division of Highways manual "Traffic Control For Street and Highway Construction and Maintenance Operations".
5. APPLICANT agrees to comply with all applicable state and federal laws in the performance of work under this permit.
6. Supplementary conditions cited on the reverse side of this permit are understood and agreed to be a part hereof.
7. The work authorized under this permit shall be completed on or before (Date): April 12, 2014

RECOMMENDED:

*Dennis Rouse*  
Title PERMIT SUPERVISOR

*Ernie B. Sney*  
Signature and Title of Applicant

BOND REQUIREMENT:

BOND NO. LPM 9062891 /DATE 2/21/2012  
Attached  On File   
INSPECTION: Owner/Consultant   
Full Time  Part Time   
Periodic  Reimbursable  No Cost

APPROVED:

*Greg Pulley*  
Title DISTRICT MANAGER  
West Virginia Division of Highways

AUTHORIZATION NO: \_\_\_\_\_

PERMIT NO: 0420130394

## CHAPTER 17 WEST VIRGINIA CODE, 1931

### §17-4-8. Use of roadbed by railroad, telephone company, etc.

No railroad or electric or other railway shall be constructed upon the roadbed of any state road, except to cross the same, nor shall any person, firm or corporation enter upon or construct any works in or upon such road, or lay or maintain thereon or thereunder any drainage, sewer or water pipes, gas pipes, electric conduits or other pipes, nor shall any telephone, telegraph or electric line or power pole, or any other structure whatsoever, be erected upon, in or over any portion of a state road, except under such restrictions, conditions and regulations as may be prescribed by the state road commissioner. Whenever any railroad or electric or other railway, heretofore or hereafter constructed, shall cross any state road, it shall be required to keep its own roadbed, and the bed of the road or highway at such crossing, in proper repair, or else to construct and maintain an overhead or undergrade crossing, subject to the approval of the state road commissioner; and the tracks of such railroad or railway at grade crossings shall be so constructed as to give a safe and easy approach to and across the same, and when the construction of such approaches is made necessary by a change in the railroad grade at the grade crossing, the cost shall be upon the railway company.

### §17-16-6. Permit by commission or county court for openings in or structures on public roads; franchises and easements of oil, etc., transportation companies.

No opening shall be made in any state or county-district road or highway, nor shall any structure be placed therein or thereover, nor shall any structure, which has been so placed, be changed or removed, except in accordance with a permit from the state road commission or county court, as the case may be. No road or highway shall be dug up for laying or placing pipes, sewers, poles or wires, or for other purposes, and no trees shall be planted or removed or obstructions placed thereon, without the written permit of the commission or county court, or its duly authorized agent, and then only in accordance with the regulations of the commission or court. The work shall be done under the supervision and to the satisfaction of the commission or court; and the entire expense of replacing the highway in as good condition as before shall be paid by the persons to whom the permit was given, or by whom the work was done: **Provided, however,** That nothing herein contained shall be so construed as to prevent any oil or gas company or person having a proper permit or franchise from transporting oil or gasoline along any of the public highways of this State, nor to give such company a franchise without paying to the landowners through whose lands such road passes the usual and customary compensation paid or to be paid to the landowners for such right of way. Any grant or franchise when made shall be construed to give to such company or person only the right to use the easement in such public road.

A violation of any provision of this section shall be a misdemeanor, and the person or corporation violating the same shall, upon conviction thereof, be fined not less than twenty-five nor more than one hundred dollars for each offense.

### §17-16-9. Private driveways or approaches to roads; obstruction of ditches.

The owner or tenant of land fronting on any state road shall construct and keep in repair all approaches or driveways to and from the same, under the direction of the state road commission, and, likewise, the owner or tenant of land fronting on any county-district road shall construct and keep in repair approaches or driveways to and from the same, under the direction of the county road engineer, and it shall be unlawful for such owner or tenant to fill up any ditch, or place any material of any kind or character in any ditch, so as in any manner to obstruct or interfere with the purposes for which it was made.

## SUPPLEMENTARY CONDITIONS

1. The person, firm or corporation to whom a permit is issued agrees to hold the State of West Virginia and DIVISION harmless on account of any damages to persons or property which may arise during the process of the work authorized by this permit or by reason thereof.
2. Applications for permission to perform work within highway rights of way shall be made on DIVISION'S standard permit form and shall be signed by the authorized representative of the person, firm or corporation applying.
3. The APPLICANT shall give detailed information concerning the work to be performed and the application must include a sketch sufficient to show the nature of the work performed.
4. APPLICANT, his agents, successor, heirs or assigns, contractors or any other person, firm or corporation working under APPLICANT'S real or apparent authority, shall perform the work in a manner satisfactory to DIVISION. Damage to the road resulting at any time from work authorized under this permit shall be repaired by APPLICANT. Unsatisfactory repairs may be corrected by DIVISION or its authorized agent and the cost thereof paid by APPLICANT.
5. DIVISION assumes no liability for damage to the proposed work by reason of construction or maintenance work on the road.
6. This permit is granted subject to removal of the authorized installation by APPLICANT at no cost to DIVISION when required for improvement of the road, and subject to all regulations now or hereafter adopted by DIVISION.
7. Utility installation shall be in accordance with the current manual, "Accommodation of Utilities on Highway Right of Way".
8. Driveways shall be in accordance with the current manual, "Rules and Regulations for Constructing Driveways on State Highway Rights-of-Way."
9. DIVISION reserves the right to cancel this permit at any time, should APPLICANT fail to comply with the terms and conditions under which it is granted.
10. This permit is granted only insofar as the DIVISION has a right to do so.

**Addendum to Permit 04-2013-0394**

This addendum, made this 13<sup>th</sup> day of May 2013, between the West Virginia Department of Transportation, Division of Highways, a statutory company hereinafter called the Division and

Antero Resources

Address: 1625 17<sup>th</sup> Street, Denver, CO 80202

Phone: 303 357-7310

hereinafter called APPLICANT.

The Applicant has filed with the DIVISION a written application for the following named route and location:

Doddridge County Route SLS 50/24, Antioch Road @ MP 0.00 to 0.032, Pearl Jean Well pad.

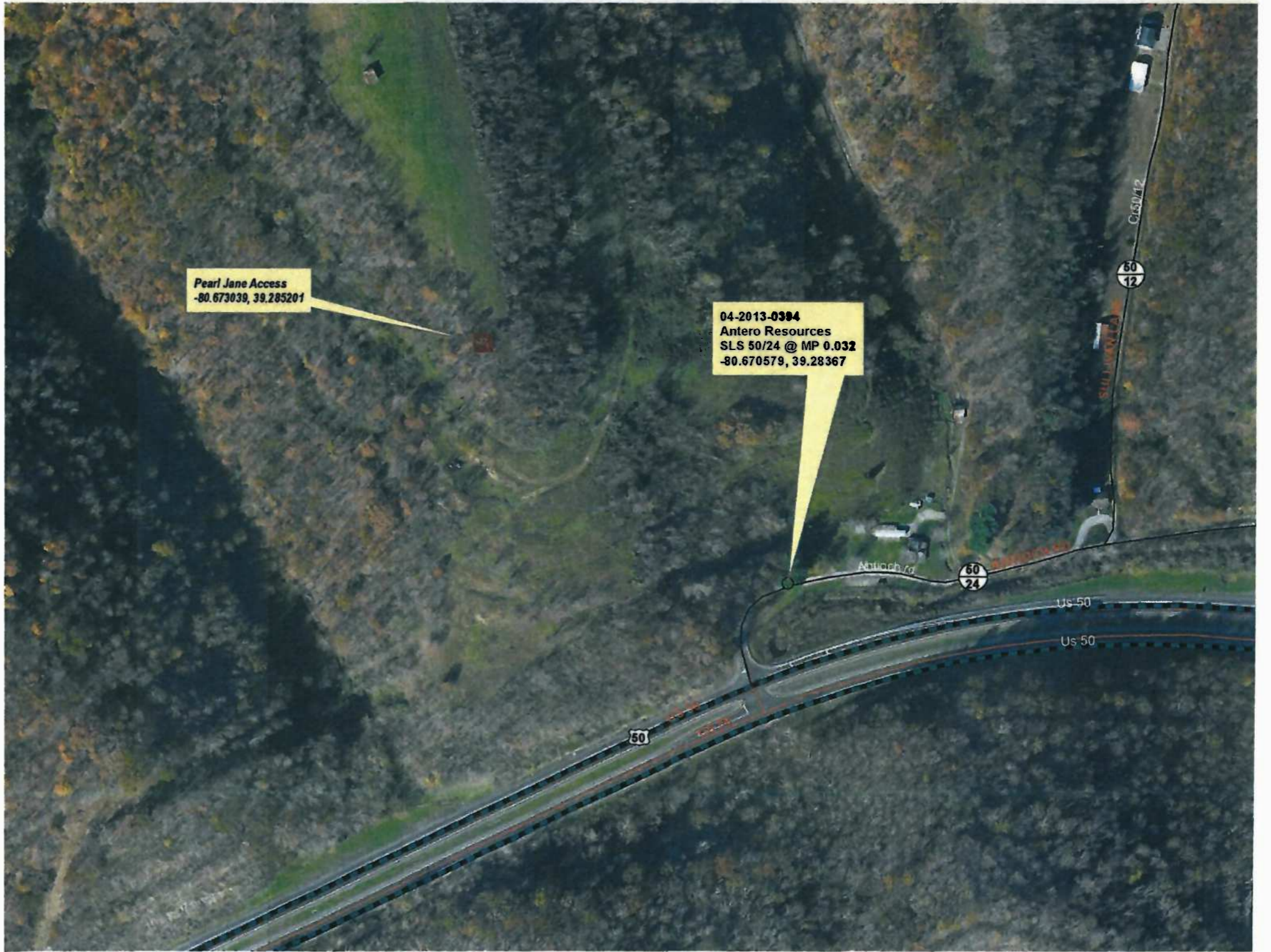
- After completion of the project, a joint review of roads will be filmed and evaluated to assure roads have been repaired to existing condition or better.
- No travel on School Bus Routes during their traversing operational hours on above mentioned route on bi-directional roadways where the lane widths are less than 10 ft.
- Pilot Vehicle required for all Oversized Loads on covered roads.
- Ditch lines to be maintained by applicant. **FDR or equivalent required to stabilize road to uphold increased traffic and heavy and excess amount of loads.** Centerline of roadway cannot be relocated without an agreement between WV DOH and Antero Resources.
- Repairs that will include "Hot Mix Asphalt" will have the following testing requirement: The supplier will be responsible for testing at the plant; Compaction testing will be as per WV DOH specifications.
- The Division of Highways shall have the right at all times to inspect the work, and if such inspections should reveal that the work is not done according to specifications, upon being so advised by the Division, ANTERO Resources agrees to take immediate corrective actions.

---

Applicant shall properly repair and maintain any and all damages that may result to said bridges, highways, shoulders and ditches from hauling activities of Applicant, its agents, contractors and employees, to as good a condition prior to commencement of Applicant's operation or as when the permit was issued, as determined by the District Engineer/Manager of the DIVISION having jurisdiction over the work permitted, or pay damages therefore in the amount to sufficiently restore such bridges, roads, highways, shoulders and ditches to original condition; and shall reimburse the DIVISION for all inspection costs incurred by it in connection with said work and repairs of such damages and faithfully comply with all terms and conditions of said permits and save harmless the DIVISION and the State of West Virginia from all losses resulting from the conduct of said work and repairs; provided that all projects covered by this blanket bond have been restored to original or better condition; then this Bond shall be released; or otherwise will remain in full force and effect.

Bond Amount: \$1,000,000.00

Bond Number: LPM9062891      Date: 2/21/2012



Pearl Jane Access  
-80.673039, 39.285201

04-2013-0394  
Antero Resources  
SLS 50/24 @ MP 0.032  
-80.670579, 39.28367

60  
12

60  
24

50

US-50

US-50

Antioch rd

Cuscuta

Dist. Permit Number 0420180394

BOND Number LPM 9062891

OIL and GAS DATA INFORMATION SHEET

APPLICANT:

Company Name ANTERO RESOURCES APPALCHIAN CORPORATION

Address 1625 17<sup>TH</sup> STREET

City DENVER ST CO Zip 80202

Contact Person Permit Burt Simcox Telephone (304) 282-9372

24/7 Road Maintenance Contact Aaron Kunzler Telephone \_\_\_\_\_ Cell (405) 227-8344

24/7 Backup Contact Dusty Wood Telephone \_\_\_\_\_ Cell (817) 771-1436

Drilling/Fracking will require \_\_\_\_\_ Less than 5000 Barrels of fluids  5000/+

Site Location

Site Name Pearl Jane Access Road Local Name Antioch Road Rte.# 50/24

Approach location WGS 83 Decimal Format GPS 39.283670 W: 80.670579 County Doddridge

Location Description

On Route.# 50/24 being .076 miles N S E (W) of Jct. of Rte.# 50/24 and Rte.# US 50

DOH USE ONLY HAULING ROUTE From US or WV Route (Attach Map)

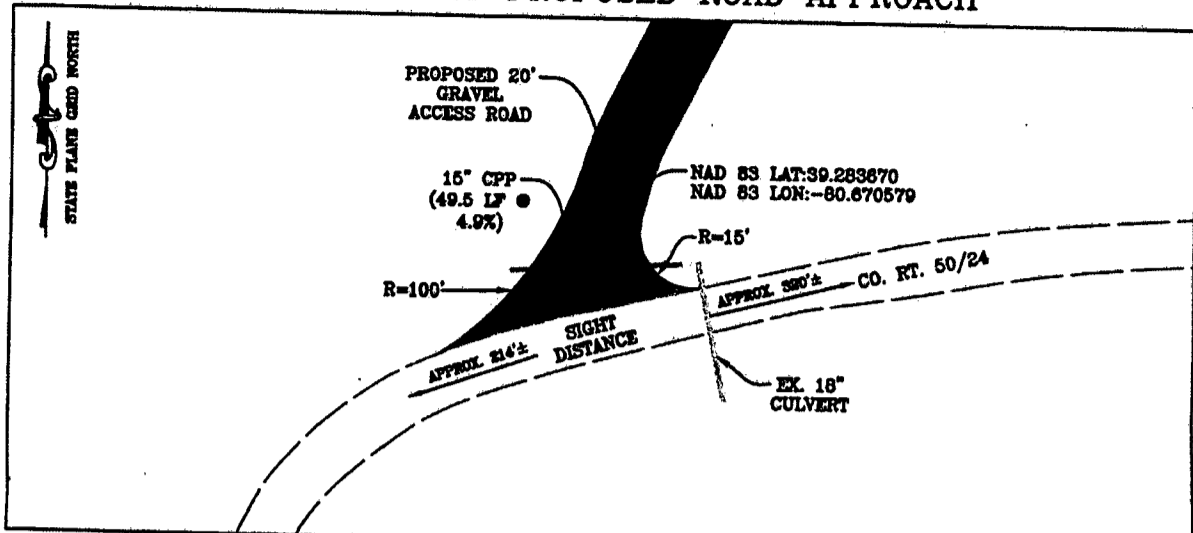
Name & Rte.#	Beg MP	End MP	Surface Type	Condition
<u>50/24</u>	<u>0.00</u>	<u>0.032</u>	<u>H.L.B.C.</u>	<u>Excellent</u>
_____	_____	_____	_____	_____
_____	_____	_____	_____	_____
_____	_____	_____	_____	_____
_____	_____	_____	_____	_____
_____	_____	_____	_____	_____
_____	_____	_____	_____	_____
_____	_____	_____	_____	_____
_____	_____	_____	_____	_____
_____	_____	_____	_____	_____
_____	_____	_____	_____	_____

Well location WGS 83 Decimal Format GPS 39.285201 N: \_\_\_\_\_ W: 80.673039

WV DEP Permit Number 47 - \_\_\_\_\_ - \_\_\_\_\_

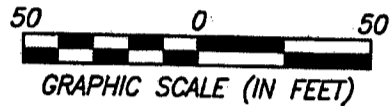
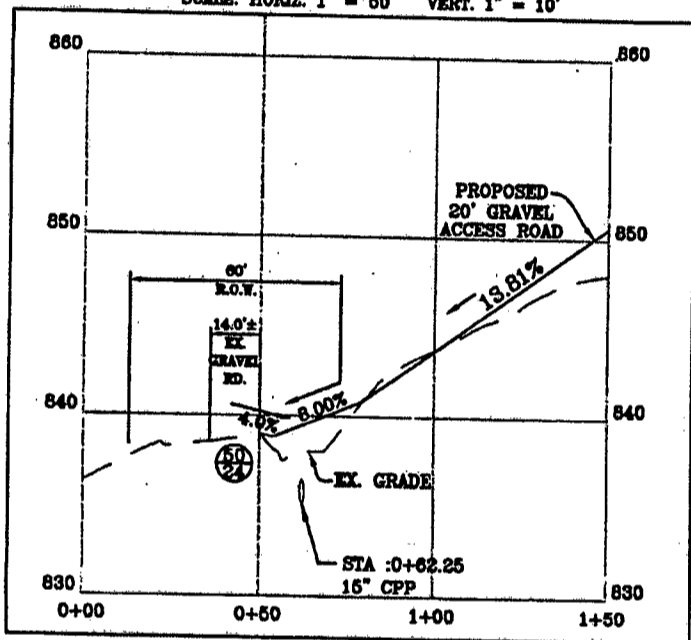
STATE COUNTY PERMIT NUMBER

# PLAN VIEW OF PROPOSED ROAD APPROACH



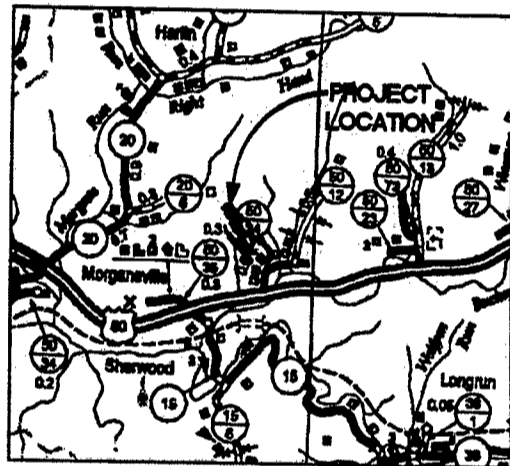
## APPROACH PROFILE

SCALE: HORIZ. 1" = 50' VERT. 1" = 10'



## VICINITY MAP

N.T.S.



### NOTES:

ALL SPECIFICATIONS AS SET FORTH IN THE "RULES AND REGULATIONS FOR CONSTRUCTION OF DRIVEWAYS ON STATE HIGHWAY RIGHT-OF-WAY" WHICH ARE APPLICABLE WILL BE CARRIED OUT IN FULL.

### LOCATION:

PROPOSAL TO CONSTRUCT AND MAINTAIN A PROPOSED 20 FT. COMMERCIAL APPROACH ON THE NORTHWEST SIDE OF CO RT. 50/24, 0.06 MILES NORTHWEST OF THE INTERSECTION OF CO RT. 50/24 & HWY. 50 IN GRANT DISTRICT, DODDRIDGE COUNTY, WEST VIRGINIA.



**NAVITUS**  
ENGINEERING INC.

151 Windy Hill Lane  
Winchester, Virginia 22602  
Telephone: (888) 662-4185  
www.navituseng.com

Engineering ◀ Survey ◀ Environmental ◀ GIS

### PREPARED FOR:

**ANTERO RESOURCES**  
981 EAST WASHINGTON AVENUE  
ELLENBORO, WV 26346

**PEARL JEAN SITE**

**DODDRIDGE COUNTY, WEST VIRGINIA**

DESIGNED BY: CSK

DATE: 02/14/2013

FILE NO: ANTO18

SCALE: AS SHOWN

0420130394



Permit: 04-2013-0394

Applicant: Antero

Addendum Continued  
Conditions and Requirements  
Repairs/Upgrades Necessary for Maintenance Permit

County: Dodd

Well Pad: Pearl Seam

Route No.	Route Name	Mile Post	Perform Ditching	Patch Potholes	Clean Culverts	Repair Base Failures	Slip Repair	Overlay Asphalt	Overlay S&C	Stone/Stabilize Roadway	Stone/Repair Shoulders	Bridge Concerns	Ongoing Roadway Maintained	Other	Approach Coordinates:		Comments
															N	W	
<u>50/24</u>	<u>Antioch road</u>	<u>0.0</u>															<u>Road in excellent condition</u>
<u>5</u>		<u>0.032</u>															

RECOMMENDATIONS: \_\_\_\_\_  
\_\_\_\_\_  
\_\_\_\_\_

Above routes reviewed for necessary repairs and upgraded required for Maintenance Permit/Agreement.

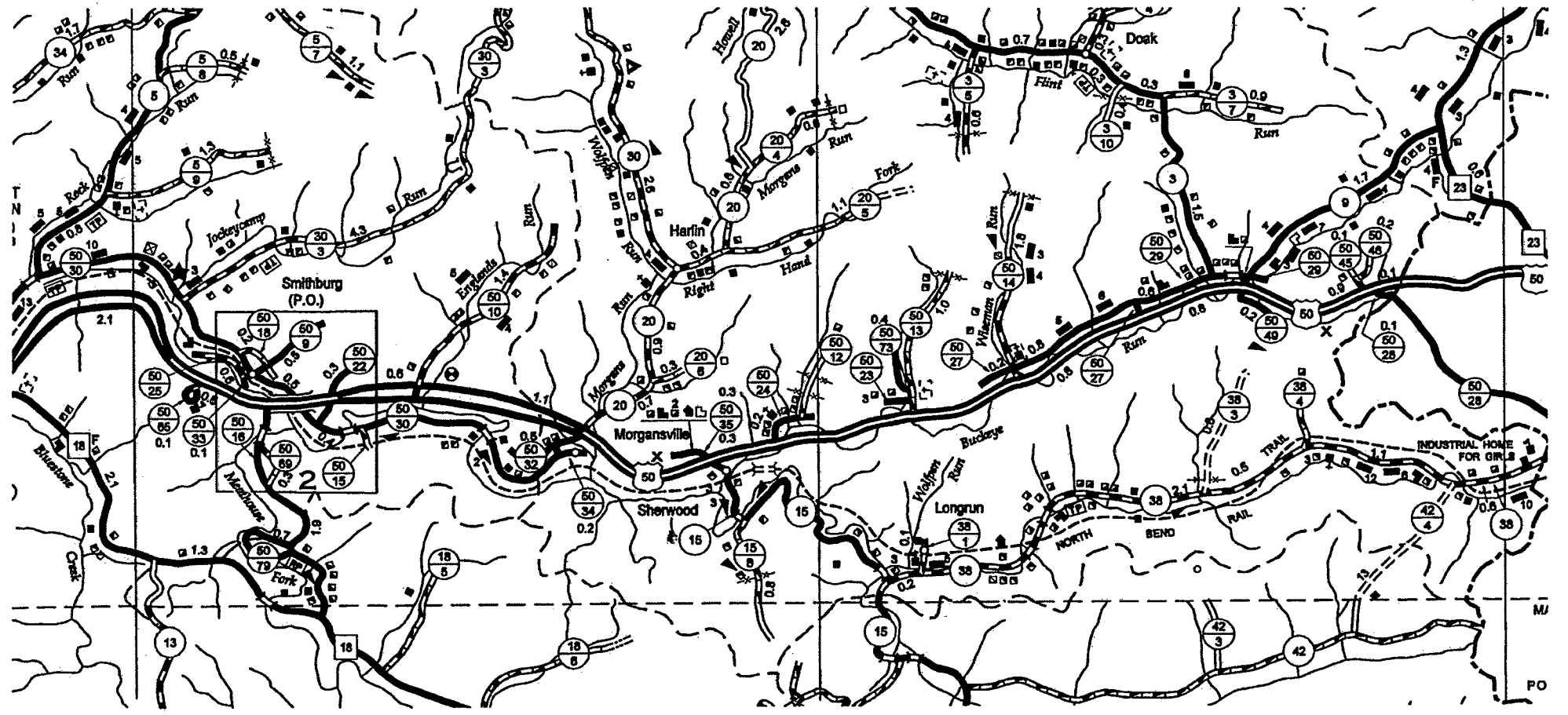
Burt Jay  
Applicant Representative

5/13/2013  
Date

Kevin O. Corbett  
DOH Representative

5/13/2013  
Date

0420180394



0420130394

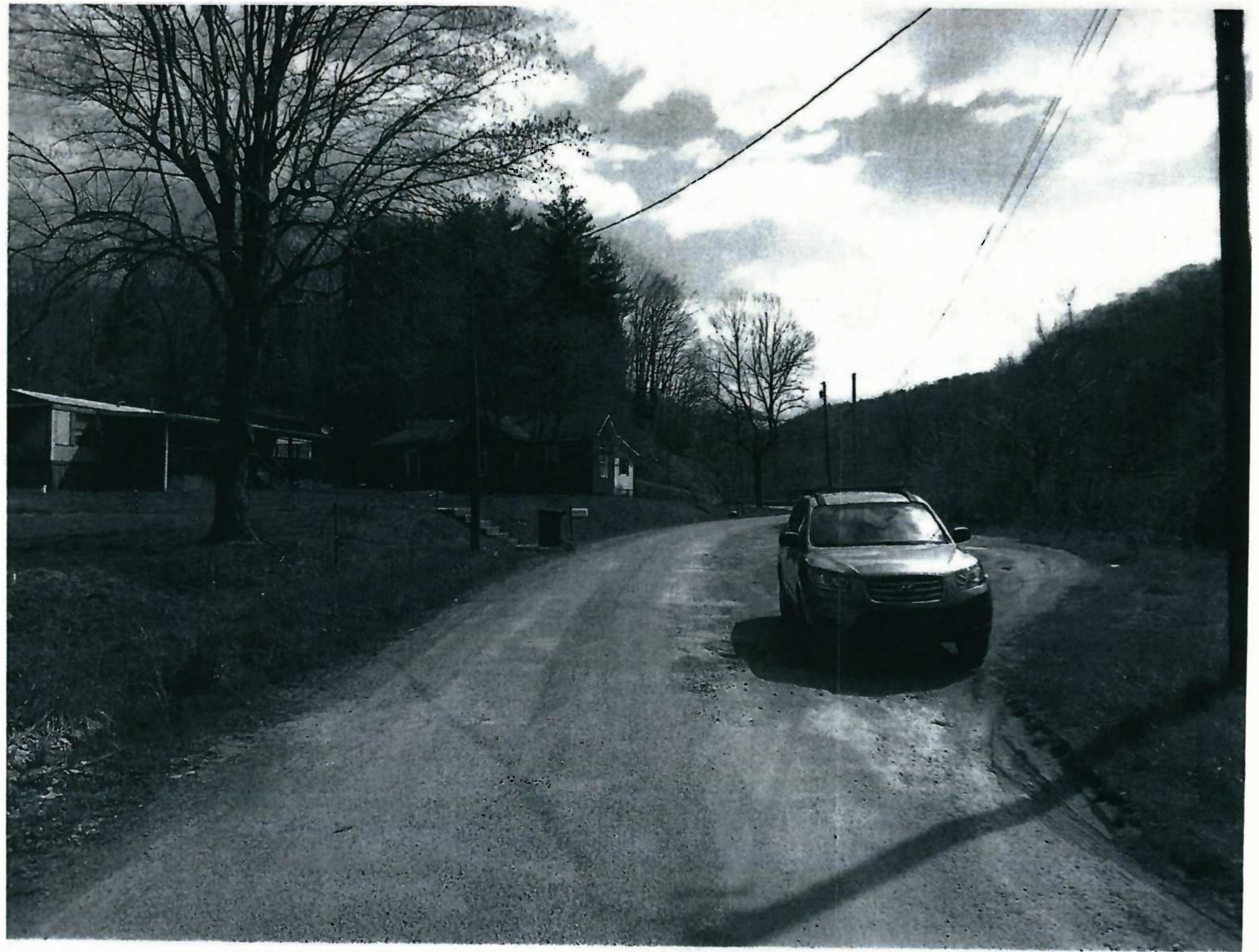


Google earth





0420180004



© 2004  
A  
C  
C  
E  
S  
S  
I  
B  
L  
E



0420130394



W  
H  
A  
T  
C  
O  
U  
L  
D  
H

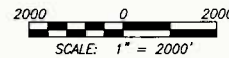
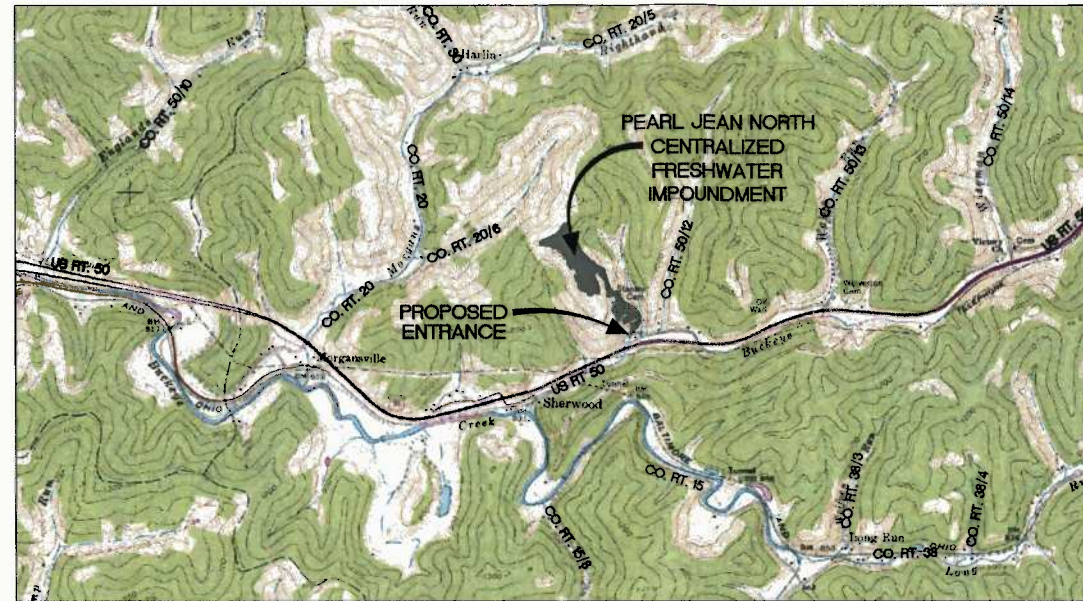




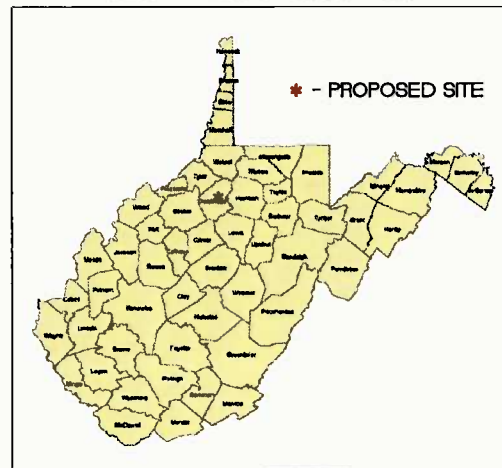
# PEARL JEAN NORTH CENTRALIZED FRESHWATER IMPOUNDMENT SITE DESIGN & CONSTRUCTION PLAN, EROSION & SEDIMENT CONTROL PLANS

GRANT DISTRICT, DODDRIDGE COUNTY, WEST VIRGINIA  
MORGAN'S RUN & BUCKEYE RUN WATERSHEDS

USGS 7.5 SMITHBURG QUAD MAP

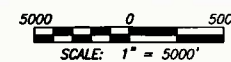
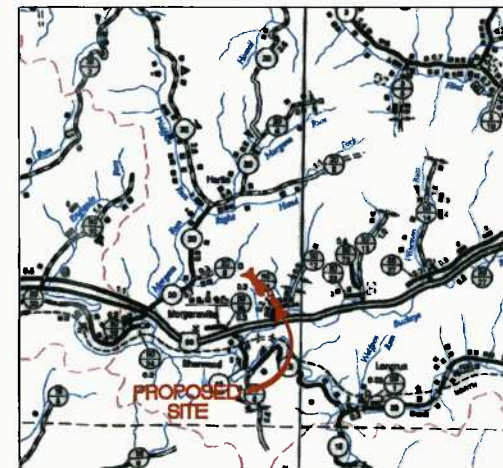


WEST VIRGINIA COUNTY MAP



(NOT TO SCALE)

WVDOH COUNTY ROAD MAP



MISS Utility of West Virginia  
1-800-245-4848  
West Virginia State Law  
(Section XIV: Chapter 24-C)  
Requires that you call two  
business days before you dig in  
the state of West Virginia.  
IT'S THE LAW!!

WEST VIRGINIA STATE PLANE COORDINATE SYSTEM  
NORTH ZONE, NAD83  
ELEVATION BASED ON NAVD83  
ESTABLISHED BY SURVEY GRADE GPS & OPUS  
POST-PROCESSING

**SHEET INDEX**

- 01 - COVER SHEET
- 02 - CONSTRUCTION AND E&S CONTROL NOTES
- 03 - MATERIAL QUANTITIES
- 04 - EXISTING CONDITIONS
- 05 - OVERALL PLAN SHEET INDEX & VOLUMES
- 06 - ACCESS ROAD PLAN
- 07 - CENTRALIZED FRESHWATER IMPOUNDMENT PLAN
- 08-09 - ACCESS ROAD PROFILES
- 10-12 - ACCESS ROAD SECTIONS
- 13 - CENTRALIZED FRESHWATER IMPOUNDMENT SECTIONS
- 14-18 - CONSTRUCTION DETAILS
- 19-20 - RECLAMATION PLAN

Limits Of Disturbance Area (ac)	
Total Site	
Access Road "A" (2,325')	6.68
Access Road "B" (804')	1.84
Access Road "C" (432')	1.06
Tank Storage Area	2.01
Centralized Impoundment	3.08
Truck Turnaround Pad	0.49
Excess/Topsoil Material Stockpiles	4.84
<b>Total Affected Area</b>	<b>20.00</b>
Total Wooded Acres Disturbed	5.03
<b>Impacts to Dean R. &amp; Martha A. Pennington TM 20-1</b>	
Access Road "A" (155')	0.32
<b>Total Affected Area</b>	<b>0.32</b>
Total Wooded Acres Disturbed	0.07
<b>Impacts to Dean R. &amp; Martha A. Pennington TM 17-28</b>	
Access Road "A" (2,005')	6.07
Access Road "B" (102')	0.39
Excess/Topsoil Material Stockpiles	2.76
<b>Total Affected Area</b>	<b>9.22</b>
Total Wooded Acres Disturbed	3.34
<b>Impacts to Dean R. &amp; Martha A. Pennington TM 16-21</b>	
Access Road "A" (165')	0.29
Access Road "B" (702')	1.46
Access Road "C" (432')	1.06
Tank Storage Area	2.01
Centralized Impoundment	3.08
Truck Turnaround Pad	0.49
Excess/Topsoil Material Stockpiles	2.08
<b>Total Affected Area</b>	<b>10.47</b>
Total Wooded Acres Disturbed	1.62

**NOTE:**  
1. THE PEARL JEAN LOCATION CONSISTS OF TWO (2) CENTRALIZED FRESHWATER IMPOUNDMENTS. SEPARATE PLAN SETS HAVE BEEN PREPARED FOR EACH FACILITY.

**LOCATION COORDINATES**

ACCESS ROAD ENTRANCE  
LATITUDE: 39.283670 LONGITUDE: -80.670579 (NAD 83)  
N 4348308.23 E 528410.92 (UTM, NAD 83, ZONE 17 METERS)

CENTER OF CENTRALIZED FRESHWATER IMPOUNDMENT  
LATITUDE: 39.288155 LONGITUDE: -80.674837 (NAD 83)  
N 4348804.69 E 528059.15 (UTM, NAD 83, ZONE 17 METERS)

**GENERAL DESCRIPTION**

THE ACCESS ROAD(S) AND CENTRALIZED FRESHWATER IMPOUNDMENT ARE BEING CONSTRUCTED TO AID IN THE DEVELOPMENT OF INDIVIDUAL MARCELLUS SHALE GAS WELLS.

**FLOODPLAIN NOTE**

THE PROPOSED SITE IS LOCATED IN FLOODZONE "X" PER FEMA FLOOD MAP #64017C0145C.

**MISS UTILITY STATEMENT**

ANTERO RESOURCES APPALACHIAN CORPORATION WILL NOTIFY MISS UTILITY OF WEST VIRGINIA FOR THE LOCATING OF UTILITIES PRIOR TO THIS PROJECT DESIGN; TICKET #1308417472. IN ADDITION, MISS UTILITY WILL BE CONTACTED PRIOR TO START OF THE PROJECT.

**ENTRANCE PERMIT**

ANTERO RESOURCES APPALACHIAN CORPORATION WILL OBTAIN AN ENCROACHMENT PERMIT (FORM MM-109) FROM THE WEST VIRGINIA DEPARTMENT OF TRANSPORTATION DIVISION OF HIGHWAYS, PRIOR TO COMMENCEMENT OF CONSTRUCTION ACTIVITIES.

**GEOTECHNICAL NOTE**

THE PROPOSED ACCESS ROAD CUT SLOPE (1.5:1) SHALL BE FIELD VERIFIED BY A CERTIFIED GEOTECHNICAL ENGINEER TO ENSURE THE PROPOSED SLOPES ARE ADEQUATE PRIOR TO CONSTRUCTION. ACCESS ROAD CONSTRUCTION SHALL BE MONITORED BY A GEOTECHNICAL ENGINEER DURING CONSTRUCTION.

A SUBSURFACE INVESTIGATION OF THE PROPOSED SITE WAS PERFORMED BY G.A. COVEY ENGINEERING, PLLC ON JANUARY 23, 31, FEBRUARY 05, & 06, 2013. THE REPORT PREPARED BY G.A. COVEY ENGINEERING, PLLC, DATED FEBRUARY 06, 2013, REFLECTS THE RESULTS OF THE SUBSURFACE INVESTIGATION. THE INFORMATION AND RECOMMENDATIONS CONTAINED IN THIS REPORT WAS USED IN THE PREPARATION OF THESE PLANS. PLEASE REFER TO THE SUBSURFACE INVESTIGATION REPORT BY G.A. COVEY ENGINEERING, PLLC FOR ADDITIONAL INFORMATION, AS NEEDED.

**ENVIRONMENTAL NOTES**

WETLAND DELINEATIONS WERE PERFORMED ON OCTOBER/NOVEMBER BY GAI CONSULTANTS TO REVIEW THE SITE FOR WATERS AND WETLANDS THAT ARE MOST LIKELY WITHIN THE REGULATORY PURVIEW OF THE U.S. ARMY CORPS OF ENGINEERS (USACE) AND/OR THE WEST VIRGINIA DEPARTMENT OF ENVIRONMENTAL PROTECTION (WVDEP). THE NOVEMBER 2, 2012 RESOURCE LOCATION MAP WAS PREPARED BY GAI CONSULTANTS, INC. AND SUMMARIZES THE RESULTS OF THE FIELD DELINEATION. THE EXHIBIT DOES NOT, IN ANY WAY, REPRESENT A JURISDICTIONAL DETERMINATION OF THE LANDWARD LIMITS OF WATERS AND WETLANDS WHICH MAY BE REGULATED BY THE USACE OR THE WVDEP.

**PROJECT CONTACTS**

**OPERATOR:**  
ANTERO RESOURCES APPALACHIAN CORPORATION  
981 EAST WASHINGTON AVENUE  
ELLENBORO, WV 26346  
PHONE: (304) 869-3405  
FAX: (304) 869-3408

ELI WAGONER - ENVIRONMENTAL ENGINEER  
OFFICE: (304) 822-3842, EXT. 311 CELL: (304) 476-9770

CHRIS BROWN - WATER RESOURCES  
OFFICE: (304) 822-3842 CELL: (304) 877-8233

JOHN KAWCAK - OPERATIONS SUPERINTENDENT  
CELL: (817) 388-1553

AARON KUNZLER - CONSTRUCTION SUPERVISOR  
CELL: (405) 227-8344

ANTHONY SMITH - FIELD ENGINEER  
OFFICE: (304) 869-3405 CELL: (304) 873-8196

DAVID PATSY - LAND AGENT  
CELL: (304) 476-8090

**ENGINEER/SURVEYOR:**  
NAVITUS ENGINEERING, INC.  
CYRUS S. KUMP, PE - PROJECT MANAGER/ENGINEER  
OFFICE: (888) 862-4185 CELL: (540) 868-8747

**ENVIRONMENTAL:**  
GAI CONSULTANTS, INC.  
JASON A. COOK - SENIOR ENVIRONMENTAL SPECIALIST  
OFFICE: (304) 928-8100 CELL: (303) 709-3306

**RESTRICTIONS NOTES:**

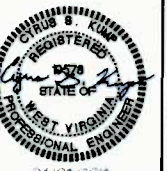
1. THERE ARE NO WETLANDS, LAKES, WETLANDS, PONDS, OR RESERVOIRS WITHIN 100 FEET OF THE CENTRALIZED FRESHWATER IMPOUNDMENT. THERE IS A PERENNIAL STREAM ADJACENT TO THE ACCESS ROAD ENTRANCE WHICH WILL REMAIN UNDISTURBED.
2. THERE ARE NO NATURALLY PRODUCING TROUT STREAMS WITHIN 300 FEET OF THE CENTRALIZED FRESHWATER IMPOUNDMENT.
3. THERE ARE NO GROUNDWATER INTAKE OR PUBLIC WATER SUPPLY FACILITIES WITHIN 1000 FEET OF THE CENTRALIZED FRESHWATER IMPOUNDMENT.
4. THERE ARE NO EXISTING WATER WELLS OR DEVELOPED SPRINGS WITHIN 250 FEET OF THE CENTRALIZED FRESHWATER IMPOUNDMENT.
5. THERE ARE NO OCCUPIED DWELLING STRUCTURES WITHIN 625 FEET OF THE CENTER OF THE CENTRALIZED FRESHWATER IMPOUNDMENT.
6. THERE ARE NO AGRICULTURAL BUILDINGS LARGER THAN 2,500 SQUARE FEET WITHIN 625 FEET OF THE CENTER OF THE CENTRALIZED FRESHWATER IMPOUNDMENT.



DATE	REVISION	UPDATE PER CLIENT REQUEST
04/03/2013		



**PEARL JEAN NORTH  
CENTRALIZED FRESHWATER IMPOUNDMENT  
GRANT DISTRICT  
DODDRIDGE COUNTY, WEST VIRGINIA**



DATE: 04/03/2013  
SCALE: AS SHOWN  
SHEET 1 OF 20

# CONSTRUCTION AND E&S CONTROL NOTES

## CONSTRUCTION NOTES:

- THE CONTRACTOR IS TO VERIFY FIELD CONDITIONS PRIOR TO AND DURING CONSTRUCTION AND WILL NOTIFY NAVITUS ENGINEERING AT (888) 682-4186 IMMEDIATELY OF ANY DISCREPANCIES BETWEEN ACTUAL FIELD CONDITIONS AND THE APPROVED PLAN. ANY WORK PERFORMED BY THE CONTRACTOR AFTER THE FINDING OF SUCH DISCREPANCIES, SHALL BE DONE AT THE CONTRACTOR'S RISK.
- METHODS AND MATERIALS USED IN THE CONSTRUCTION OF THE IMPROVEMENTS HEREIN SHALL CONFORM TO THE CURRENT COUNTY CONSTRUCTION STANDARDS AND SPECIFICATIONS AND/OR CURRENT WV DEP EROSION AND SEDIMENT CONTROL BEST MANAGEMENT PRACTICE MANUAL STANDARDS AND SPECIFICATIONS. SHOULD A CONFLICT BETWEEN THE DESIGN, SPECIFICATIONS, AND PLANS OCCUR, THE MOST STRINGENT REQUIREMENT WILL APPLY. THE APPROVAL OF THESE PLANS IN NO WAY RELIEVES THE DEVELOPER OR HIS AGENT OF THE RESPONSIBILITIES CONTAINED IN THE WV DEP EROSION AND SEDIMENT CONTROL BEST MANAGEMENT PRACTICE MANUAL.
- AN APPROVED SET OF PLANS AND ALL APPLICABLE PERMITS MUST BE AVAILABLE AT THE CONSTRUCTION SITE. ALSO, A REPRESENTATIVE OF THE DEVELOPER MUST BE AVAILABLE AT ALL TIMES.
- THE CONTRACTOR SHALL PROVIDE ADEQUATE MEANS OF CLEANING MUD FROM TRUCKS AND/OR OTHER EQUIPMENT PRIOR TO ENTERING PUBLIC STREETS. AND IT IS THE CONTRACTOR'S RESPONSIBILITY TO CLEAN STREETS, ALLAY DUST, AND TO TAKE WHATEVER MEASURES ARE NECESSARY TO INSURE THAT THE STREETS ARE MAINTAINED IN A CLEAN, MUD AND DUST FREE CONDITION AT ALL TIMES.
- THE LOCATION OF EXISTING UTILITIES SHOWN IN THESE PLANS ARE FROM FIELD LOCATIONS. IT SHALL BE THE CONTRACTOR'S RESPONSIBILITY TO VERIFY THE EXACT HORIZONTAL AND VERTICAL LOCATION OF ALL EXISTING UTILITIES AS NEEDED PRIOR TO CONSTRUCTION. THE CONTRACTOR SHALL INFORM THE ENGINEER OF ANY CONFLICTS ARISING FROM HIS EXISTING UTILITY VERIFICATION AND THE PROPOSED CONSTRUCTION.
- THE CONTRACTOR SHALL PROVIDE NOTIFICATION TO THE APPROPRIATE UTILITY COMPANY PRIOR TO CONSTRUCTION OF WATER AND/OR GAS PIPE LINES. INFORMATION SHOULD ALSO BE OBTAINED FROM THE APPROPRIATE AUTHORITY CONCERNING PERMITS, CUT SHEETS, AND CONNECTIONS TO EXISTING LINES.
- THE CONTRACTOR WILL BE RESPONSIBLE FOR THE REPAIR OF ANY DAMAGES TO THE EXISTING STREETS AND UTILITIES WHICH OCCURS AS A RESULT OF HIS CONSTRUCTION PROJECT WITHIN OR CONTIGUOUS TO THE EXISTING RIGHT-OF-WAY.
- WHEN GRADING IS PROPOSED WITHIN EASEMENTS OF UTILITIES, LETTERS OF PERMISSION FROM ALL INVOLVED COMPANIES MUST BE OBTAINED PRIOR TO GRADING AND/OR SITE DEVELOPMENT.
- THE DEVELOPER WILL BE RESPONSIBLE FOR THE RELOCATION OF ANY UTILITIES WHICH IS REQUIRED AS A RESULT OF HIS PROJECT. THE RELOCATION SHOULD BE DONE PRIOR TO CONSTRUCTION.
- THESE PLANS IDENTIFY THE LOCATION OF ALL KNOWN GRAVESITES. GRAVESITES SHOWN ON THIS PLAN WILL BE PROTECTED IN ACCORDANCE WITH STATE LAW. IN THE EVENT GRAVESITES ARE DISCOVERED DURING CONSTRUCTION, THE OWNER AND ENGINEER MUST BE NOTIFIED IMMEDIATELY.
- THE CONTRACTOR(S) SHALL NOTIFY OPERATORS WHO MAINTAIN UNDERGROUND UTILITY LINES IN THE AREA OF PROPOSED EXCAVATING OR BLASTING AT LEAST TWO (2) WORKING DAYS, BUT NOT MORE THAN TEN (10) WORKING DAYS, PRIOR TO COMMENCEMENT OF EXCAVATION OR DEMOLITION.
- CONTRACTOR TO CONTACT OPERATOR AND ENGINEER IF GROUNDWATER IS ENCOUNTERED DURING CONSTRUCTION.
- THE CONTRACTOR SHALL SCHEDULE A PRE-CONSTRUCTION MEETING WITH THE EROSION AND SEDIMENT CONTROL INSPECTOR, 2 DAYS PRIOR TO THE START OF CONSTRUCTION.
- THE CONTRACTOR IS RESPONSIBLE FOR ALL FILL MATERIAL TESTING REQUIRED DURING THE CONSTRUCTION OF THIS PROJECT. ALL MATERIAL TEST SHALL BE CONDUCTED BY A CERTIFIED MATERIALS TESTING LABORATORY AND A CERTIFICATION OF THE MATERIALS TESTED SHALL BE PROVIDED BY A LICENSED PROFESSIONAL ENGINEER REPRESENTING THE LABORATORY. ALL TEST RESULTS SHALL BE SUBMITTED TO THE ENGINEER CERTIFYING THE CONSTRUCTED FACILITY. FAILURE TO CONDUCT THE DENSITY TEST SHALL BE CAUSE FOR NON-ACCEPTANCE OF THE CONSTRUCTED FACILITY.
- THE CONTRACTOR IS RESPONSIBLE FOR CONSTRUCTING THE SITE IN ACCORDANCE WITH THE DESIGN PLANS AND CONSTRUCTION DOCUMENTS AND THE SCOPE OF WORK SHALL CONFORM WITH THE GRADES, BERMS, DEPTHS, DIMENSIONS, ETC. SHOWN HEREON.

## SITE CLEANUP & RECYCLE PROGRAM

- GARBAGE, FUELS OR ANY SUBSTANCE HARMFUL TO HUMAN, AQUATIC OR FISH LIFE, WILL BE PREVENTED FROM ENTERING SPRINGS, STREAMS, PONDS, LAKES, WETLANDS OR ANY WATER COURSE OR WATER BODY.
- OILS, FUELS, LUBRICANTS AND COOLANTS WILL BE PLACED IN SUITABLE CONTAINERS AND DISPOSED PROPERLY.
- ALL TRASH AND GARBAGE WILL BE COLLECTED AND DISPOSED PROPERLY.
- ALL SEDIMENT REMOVED FROM SEDIMENT CAPTURING DEVICES SHALL BE PLACED ON THE TOPSOIL STOCKPILE, THEN SEEDED AND MULCHED, AS NECESSARY. ALTERNATIVELY, THE REMOVED SEDIMENT CAN BE TRANSPORTED TO A SITE WITH AN APPROVED PERMIT.
- ALL POLLUTION AND EMERGENCY SPILLS SHALL BE IMMEDIATELY REPORTED TO THE WV DEP OFFICE OF OIL AND GAS. (EMERGENCY #1-800-842-3074).

## EROSION AND SEDIMENT CONTROL NARRATIVE

**PROJECT DESCRIPTION:** THE PURPOSE OF THIS PROJECT IS TO CONSTRUCT A CENTRALIZED FRESHWATER IMPOUNDMENT TO AID IN THE DEVELOPMENT OF INDIVIDUAL GAS WELLS. THE ACCESS ROAD TO THE PROPOSED SITE IS LOCATED ON THE NORTHWEST SIDE OF CO RT. 60/24, 0.08 MILES NORTHWEST OF THE INTERSECTION OF CO RT. 60/24 & HWY. 60 IN GRANT DISTRICT, DODDRIDGE COUNTY, WEST VIRGINIA. THE TOTAL APPROXIMATE LAND DISTURBANCE ASSOCIATED WITH THIS PROJECT IS 20.34 ACRES.

**EXISTING SITE CONDITIONS:** THE EXISTING SITE IS MOSTLY OPEN PASTURE WITH APPROXIMATELY 24.7% BEING WOODED. THE TOPOGRAPHY RANGES FROM MODERATE TO STEEP TERRAIN (2% TO 60% SLOPES). PRESENT ON SITE ARE THREE EXISTING GAS PIPES. ALSO PRESENT ARE ACCESS ROADS, STRUCTURES, OVERHEAD UTILITIES, ONE PERENNIAL STREAM, TWO INTERMITTENT STREAMS, ONE EPHEMERAL STREAM, AND TWO PFM WETLANDS. THE SITE IS LOCATED ON A RIDGE AND DRAINS TO MORGAN'S RUN AND BUCKEYE RUN.

**ADJACENT PROPERTY:** THE SITE IS BORDERED ON ALL SIDES BY PASTURE AND FORESTED LANDS. NEARBY STREAMS INCLUDE AN UNNAMED TRIBUTARY TO MORGAN'S RUN TO THE NORTH, AN UNNAMED TRIBUTARY TO BUCKEYE RUN TO THE EAST, BUCKEYE RUN TO THE SOUTH, AND AN ADDITIONAL UNNAMED TRIBUTARY TO BUCKEYE RUN TO THE WEST. THE SITE IS BORDERED BY CO RT. 60/24 TO THE SOUTH (LOCATION OF ACCESS ROAD ENTRANCE), HWY. 60 TO THE SOUTH, AND CO RT. 60/12 TO THE EAST.

**CRITICAL AREAS:** THE AREA(S) SHOWN ALONG THE FIELD DELINEATED STREAMS, WETLANDS, AND PONDS, AS SHOWN ON THE PLANS ARE DESIGNATED AS CRITICAL AREA(S). IF PRESENT, COMPOST FILTER SOCKS ARE TO BE USED TO PROTECT THESE FIELD DELINEATED AREA(S) FROM SEDIMENT LEAVING THE SITE. ADDITIONALLY, ORANGE SAFETY FENCE IS RECOMMENDED TO BE INSTALLED ABOVE/AROUND THESE AREA(S), TO SERVE AS A PHYSICAL BARRIER, ENSURING THE AREA(S) ARE NOT DISTURBED.

**SOILS:** THE PROPOSED ACCESS ROAD CUT SLOPE (1.5:1) SHALL BE FIELD VERIFIED BY A CERTIFIED GEOTECHNICAL ENGINEER TO ENSURE THE PROPOSED SLOPES ARE ADEQUATE PRIOR TO CONSTRUCTION. ACCESS ROAD CONSTRUCTION SHALL BE MONITORED BY A GEOTECHNICAL ENGINEER DURING CONSTRUCTION.

A SUBSURFACE INVESTIGATION OF THE PROPOSED SITE WAS PERFORMED BY G.A. COVEY ENGINEERING, PLLC ON JANUARY 23, 31, FEBRUARY 05, & 08, 2013. THE REPORT PREPARED BY G.A. COVEY ENGINEERING, PLLC DATED FEBRUARY 08, 2013, REFLECTS THE RESULTS OF THE SUBSURFACE INVESTIGATION. THE INFORMATION AND RECOMMENDATIONS CONTAINED IN THIS REPORT WAS USED IN THE PREPARATION OF THESE PLANS. PLEASE REFER TO THE SUBSURFACE INVESTIGATION REPORT BY G.A. COVEY ENGINEERING, PLLC FOR ADDITIONAL INFORMATION, AS NEEDED.

**OFF SITE AREAS:** THERE ARE NO BORROW AREA(S) OR EXPORT STOCKPILE AREA(S) OUTSIDE OF THE PROPOSED LIMITS OF DISTURBANCE FOR THIS PROJECT.

**EROSION AND SEDIMENT CONTROL MEASURES:** UNLESS OTHERWISE INDICATED, ALL VEGETATIVE AND STRUCTURAL EROSION AND SEDIMENT CONTROL MEASURES SHALL BE CONSTRUCTED AND MAINTAINED ACCORDING TO MINIMUM STANDARDS AND SPECIFICATIONS OF THE CURRENT WEST VIRGINIA EROSION AND SEDIMENT CONTROL BEST MANAGEMENT PRACTICE MANUAL.

### STRUCTURAL PRACTICES:

#### PHASE I:

- INSTALL ORANGE SAFETY FENCE TO ENSURE NO DISTURBANCE TO THE DELINEATED AREA(S).
- INSTALL TEMPORARY CONSTRUCTION ENTRANCE.
- INSTALL COMPOST FILTER SOCKS AS SHOWN ON THE PLANS AS PHASE I CONTROL MEASURES TO REMOVE SEDIMENT FROM RUNOFF. SELECTIVELY REMOVE TREES REQUIRED TO INSTALL COMPOST FILTER SOCK IN WOODED AREAS. CLEARING AND GRUBBING SHALL BE KEPT AT A MINIMUM TO INSTALL E&S CONTROLS.
- EROSION CONTROL BLANKETS (MATTING) SHALL BE PLACED ON ALL CRITICAL SLOPES (3:1 OR GREATER) AND AS NEEDED TO STABILIZE DISTURBED AREAS.

#### PHASE II:

- ALL CONTROLS INSTALLED IN PHASE I SHALL REMAIN FOR THE DURATION OF THE PROJECT.
- FILL SLOPE SURFACE SHALL BE LEFT IN A ROUGHENED CONDITION TO REDUCE EROSION. CONTRACTOR SHALL REDUCE RUNOFF AWAY FROM THE FILL SLOPE BY INSTALLING DIVERSION BERMS AND DIVERTING THE RUNOFF TO SEDIMENT TRAPPING DEVICES.
- INSTALL V-DITCHES, DITCH RELIEF CULVERTS, AND OUTLET PROTECTION (RIP-RAP APRONS) AS SHOWN ON THE PLANS.
- EROSION CONTROL BLANKETS (MATTING) SHALL BE PLACED ON ALL CRITICAL SLOPES (3:1 OR GREATER) AND AS NEEDED TO STABILIZE DISTURBED AREAS.

DEVICES LISTED ABOVE ARE CONSIDERED MINIMUM EROSION AND SEDIMENT CONTROLS. ADDITIONAL CONTROL MEASURES MAY BE NECESSARY DUE TO CONTRACTOR PHASING OR OTHER UNFORESEEN CONDITIONS. IMMEDIATELY UPON DISCOVERING UNFORESEEN CIRCUMSTANCES POSING THE POTENTIAL FOR ACCELERATED EROSION AND/OR SEDIMENT POLLUTION, THE CONTRACTOR SHALL IMPLEMENT APPROPRIATE BMP'S TO MINIMIZE THE POTENTIAL FOR EROSION AND SEDIMENT POLLUTION. ALL MEASURES SHALL BE CONSTRUCTED AND MAINTAINED ACCORDING TO MINIMUM STANDARDS AND SPECIFICATIONS OF THE CURRENT WEST VIRGINIA EROSION AND SEDIMENT CONTROL BEST MANAGEMENT PRACTICE MANUAL.

**MAINTENANCE PROGRAM:** DURING CONSTRUCTION ACTIVITIES, ALL CONTROL MEASURES SHALL BE INSPECTED DAILY BY THE SITE SUPERINTENDENT OR HIS REPRESENTATIVE AND WITHIN 24 HOURS AFTER ANY RUNOFF EVENT. ONCE CONSTRUCTION ACTIVITIES HAVE CONCLUDED, BI-WEEKLY INSPECTIONS SHALL BE PERFORMED. ANY DAMAGED STRUCTURAL MEASURES ARE TO BE REPAIRED, BY THE END OF THE DAY OR AT THE EARLIEST TIME IN WHICH IT IS SAFE TO DO SO. SEEDING AREAS SHALL BE CHECKED REGULARLY TO ENSURE THAT A GOOD STAND OF GRASS IS MAINTAINED. ALL AREAS SHALL BE FERTILIZED AND RESEDED AS NEEDED UNTIL GRASS IS ESTABLISHED.

TRAPPED SEDIMENT IS TO BE REMOVED AS REQUIRED TO MAINTAIN 60% TRAP AND/OR SOCK EFFICIENCY AND DISPOSED OF BY SPREADING ON THE STOCKPILE.

INLET OF DITCH RELIEF CULVERTS SHALL BE CHECKED REGULARLY FOR SEDIMENT BUILD-UP. IF THE GRAVEL OUTLET IS CLOGGED BY SEDIMENT, IT SHALL BE REMOVED AND CLEANED OR REPLACED IMMEDIATELY.

SEDIMENT TRACKED ONTO ANY PUBLIC ROADWAY OR SIDEWALK SHALL BE RETURNED TO THE CONSTRUCTION SITE BY THE END OF EACH WORK DAY AND DISPOSED IN THE MANNER DESCRIBED IN THIS PLAN. IN NO CASE SHALL THE SEDIMENT BE WASHED, SHOVELED OR SWEEP INTO ANY ROADSIDE DITCH, CULVERT OR SURFACE WATER.

ANY DISTURBED AREAS ALONG THE ACCESS ROAD SHALL BE STABILIZED PRIOR TO THE END OF EACH DAY WITH EITHER ROCK STABILIZATION OR SEEDING AND MULCHING METHODS.

NOTE: THE WV DEP RETAINS THE RIGHT TO ADD AND/OR MODIFY THESE EROSION AND SEDIMENT CONTROL MEASURES DURING THE CONSTRUCTION PROCESS, WITHIN REASON, TO ENSURE ADEQUATE PROTECTION TO THE PUBLIC AND THE ENVIRONMENT.

### SEEDING (SOIL STABILIZATION):

- CONTRACTOR SHALL APPLY SEED AND STABILIZATION IN ACCORDANCE WITH THE WV DEP EROSION AND SEDIMENT CONTROL BEST MANAGEMENT PRACTICE (BMP) MANUAL, BASED UPON SITE SPECIFIC SOIL CHARACTERISTICS.
- WHEREVER SEEDING IS TO BE APPLIED TO STEEP SLOPES (≥ 3H:1V), SEED MIXTURES SHOULD BE SELECTED THAT ARE APPROPRIATE FOR STEEP SLOPES.

### DUST CONTROL:

- TEMPORARY SEEDING SHALL BE APPLIED TO ALL DISTURBED AREAS SUBJECT TO LITTLE OR NO CONSTRUCTION TRAFFIC.
- ALL HAUL ROADS AND OTHER HEAVY TRAFFIC ROUTES SHALL BE SPRINKLED WITH WATER UNTIL THE SURFACE IS WET AND REPEATED AS NEEDED TO CONTROL DUST.

## CONSTRUCTION SEQUENCE

THE DEVELOPMENT OF THIS SITE SHALL BE CONSISTENT WITH THE FOLLOWING GENERAL SEQUENCE OF CONSTRUCTION. THE CONTRACTOR SHALL IMPLEMENT, MAINTAIN, AND OPERATE ALL PROPOSED EROSION AND SEDIMENT CONTROL MEASURES TO EFFECTIVELY MITIGATE THE HAZARD OF ACCELERATED EROSION AND SEDIMENTATION TO ACCEPTABLE LEVELS. MINOR DEVIATIONS FROM THIS SEQUENCE SHALL BE EXECUTED BY THE PROJECT'S SUPERINTENDENT AS NEEDED TO ELIMINATE ANY POTENTIAL EXPOSURE CONDITION THAT MAY ARISE FOR THE DURATION OF THE PROJECT. THE WV DEP OFFICE OF OIL AND GAS SHALL BE NOTIFIED OF ANY AND ALL SUCH DEVIATIONS FROM THE APPROVED PLANS.

- A PRE-CONSTRUCTION CONFERENCE WITH THE CONTRACTOR AND THE APPROPRIATE EROSION AND SEDIMENT CONTROL INSPECTOR 48 HOURS PRIOR TO BEGINNING WORK TO REVIEW THE CONSTRUCTION DRAWINGS AND PROVIDE ANY REQUESTED GUIDANCE.
- STAKE THE LIMITS OF CONSTRUCTION AND MARK ALL IDENTIFIED WETLANDS, STREAMS, AND OTHER AREAS OF CONCERN FOR CONSTRUCTION ACTIVITIES.
- CONSTRUCT THE ROCK CONSTRUCTION ENTRANCE. ALL VEHICLES ENTERING AND EXITING THE SITE SHALL DO SO VIA THE ROCK CONSTRUCTION ENTRANCE.
- CONSTRUCT ALL BMP'S AS SOON AS CLEARING AND GRUBBING OPERATIONS ALLOW. DIVERSIONS AND SEDIMENT TRAP(S)/BASIN(S) SHALL BE SEEDED AND MULCHED IMMEDIATELY.
- IF APPLICABLE, CONVEY UPSLOPE DRAINAGE AROUND THE ACCESS ROAD AND PAD/PIT AREA BY CONSTRUCTING ALL DIVERSION BERM(S) AND/OR COMPOST FILTER SOCK DIVERSION(S) AS SHOWN ON THE PLANS.
- CLEAR AND GRUB THE SITE. ALL WOODY MATERIAL, BRUSH, TREES, STUMPS, LARGE ROOTS, BOULDERS, AND DEBRIS SHALL BE CLEARED FROM THE SITE AREA AND KEPT TO THE MINIMUM NECESSARY FOR PROPER CONSTRUCTION, INCLUDING THE INSTALLATION OF NECESSARY SEDIMENT CONTROLS. TREES SIX INCHES IN DIAMETER AND LARGER SHALL BE CUT AND LOGS STACKED. SMALLER TREES, BRUSH, & STUMPS SHALL BE CUT AND/OR GRUBBED AND WINDROWED IN APPROPRIATE AREAS FOR USE AS BRUSH PILE SEDIMENT BARRIERS (AS SHOWN ON THE PLANS), WILDLIFE HABITATS, BURNED (AS PER WV FOREST FIRE LAWS), REMOVED FROM SITE, OR DISPOSED OF BY OTHER METHODS APPROVED BY WV DEP.
- IF APPLICABLE, INSTALL ALL WETLAND OR STREAM CROSSINGS AS SHOWN ON THE PLANS.
- STRIP THE TOPSOIL FROM THE ACCESS ROAD. ALL STRIPPED TOPSOIL SHALL BE STOCKPILED IN AREAS SHOWN IN THE PLANS AND IMMEDIATELY STABILIZED. ADDITIONAL BMP MEASURES SHALL BE CONSTRUCTED AROUND TOPSOIL STOCKPILES, IF NECESSARY.
- CONSTRUCT THE ACCESS ROAD. DITCH RELIEF CULVERTS SHALL BE INSTALLED AT A GRADE OF 1-8% TO MINIMIZE OUTLET VELOCITIES TO THE EXTENT POSSIBLE. INSTALL OUTLET PROTECTION ONCE DITCH RELIEF CULVERTS ARE INSTALLED, AS SHOWN ON PLANS. STABILIZE THE ROAD WITH GEOTEXTILE FABRIC & STONE AND SIDE SLOPES AS SPECIFIED WITH PERMANENT SEEDING. EXCESS MATERIAL SHALL BE STOCKPILED (IF NECESSARY) IN AREAS SHOWN IN THE PLANS AND IMMEDIATELY STABILIZED. ALL DITCH LINES SHALL BE CLEANED PRIOR TO INSTALLATION OF LINED PROTECTION.
- STRIP THE TOPSOIL FROM THE CENTRALIZED FRESHWATER IMPOUNDMENT AREA. ALL STRIPPED TOPSOIL SHALL BE STOCKPILED IN AREAS SHOWN IN THE PLANS AND IMMEDIATELY STABILIZED. ADDITIONAL BMP MEASURES SHALL BE CONSTRUCTED AROUND TOPSOIL STOCKPILES, IF NECESSARY.
- GRADE THE CENTRALIZED FRESHWATER IMPOUNDMENT AREA AS SHOWN ON THE PLANS. ALL FILL AREAS SHALL BE "KEYED IN" AND COMPACTED IN HORIZONTAL LIFTS WITH A MAXIMUM LOOSE LIFT THICKNESS OF 9" AND MAXIMUM PARTICLE SIZE OF LESS THAN 6". ALL FILL SHALL BE COMPACTED BY A VIBRATING SHEEPSFOOT ROLLER TO 95% PER THE STANDARD PROCTOR TEST (ASTM-D998).
- IMMEDIATELY STABILIZE THE OUTER AREAS OF THE CENTRALIZED FRESHWATER IMPOUNDMENT AND TURNAROUND PAD(S). THE TURNAROUND PAD(S) SHALL BE STABILIZED WITH GEOTEXTILE FABRIC & STONE AND THE SIDE SLOPES WITH EROSION CONTROL BLANKETING WHEN SLOPES ARE 3:1 OR GREATER. APPLY SEED AND MULCH TO ALL DISTURBED AREAS. THIS SHALL INCLUDE ALL AREAS THAT WILL NOT BE SUBJECT TO REGULAR TRAFFIC ACTIVITY (TO BE STABILIZED WITH STONE), OR ANY DISTURBED AREA THAT WILL NOT BE RE-DISTURBED BEFORE SITE RECLAMATION BEGINS.
- PRIOR TO THE INSTALLATION OF THE CENTRALIZED FRESHWATER IMPOUNDMENT LINER SYSTEM, THE CONTRACTOR SHALL CONTACT THE ENGINEER/SURVEYOR TO COMPLETE AN AS-BUILT SURVEY OF THE CONSTRUCTED CENTRALIZED FRESHWATER IMPOUNDMENT TO ENSURE CONFORMANCE WITH THE DESIGN DRAWINGS. THE AS-BUILT WILL BE REVIEWED BY THE ENGINEER AND THE CONTRACTOR IS RESPONSIBLE FOR ANY CORRECTIVE ACTION DEEMED NECESSARY BY THE ENGINEER FOR ANY DEVIATION(S) FROM THE DESIGN DRAWINGS.
- INSTALL THE CENTRALIZED FRESHWATER IMPOUNDMENT LINER SYSTEM AND PERMETER SAFETY FENCE W/GATE AND EMERGENCY LIFE LINE AS SHOWN ON THE PLANS. SEE DETAILS FOR ADDITIONAL INFORMATION.
- ONCE THE CENTRALIZED FRESHWATER IMPOUNDMENT HAS BEEN COMPLETED, SUBMIT THE AS-BUILT CERTIFICATION FOR THE CENTRALIZED FRESHWATER IMPOUNDMENT FACILITY TO THE WV DEP OFFICE OF OIL AND GAS, PRIOR TO PLACING FLUIDS IN THE STRUCTURE.
- COMMENCE USE OF THE CENTRALIZED FRESHWATER IMPOUNDMENT FACILITY.
- ALL BMP'S MUST REMAIN IN PLACE AND FUNCTIONAL UNTIL ALL AREAS WITHIN THE LIMIT OF DISTURBANCE ARE COMPLETE AND PERMANENTLY STABILIZED. MAINTENANCE MUST INCLUDE INSPECTION OF ALL EROSION AND SEDIMENT CONTROLS AFTER EACH RUNOFF EVENT IN EXCESS OF 0.5" AND ON A BIWEEKLY BASIS.
- THE CONSTRUCTION SITE SHOULD BE STABILIZED AS SOON AS POSSIBLE AFTER COMPLETION. ESTABLISHMENT OF FINAL COVER MUST BE INITIATED NO LATER THAN 7 DAYS AFTER REACHING FINAL GRADE. A NOTICE OF TERMINATION MUST BE FILED WITH THE DEP WHEN THE SITE REACHED FINAL STABILIZATION. FINAL STABILIZATION MEANS THAT ALL SOIL-DISTURBING ACTIVITIES ARE COMPLETED AND THAT EITHER A PERMANENT COVER WITH A DENSITY OF 70% OR GREATER HAS BEEN ESTABLISHED OR THAT THE SURFACE HAS BEEN STABILIZED BY HARD COVER SUCH AS PAVEMENT OR BUILDINGS. IT SHOULD BE NOTED THAT THE 70% REQUIREMENT REFERS TO THE TOTAL AREA VEGETATED AND NOT JUST A PERCENT OF THE SITE.
- ALL PERMANENT SEDIMENT CONTROL MEASURES CAN BE REMOVED AFTER THE SITE IS PERMANENTLY STABILIZED AND APPROVAL IS RECEIVED FROM THE WV DEP.
- ANY AREAS DISTURBED BY REMOVAL OF CONTROLS SHALL BE REPAIRED, STABILIZED, AND PERMANENTLY SEEDED.

## CENTRALIZED FRESHWATER IMPOUNDMENT CONSTRUCTION STANDARDS

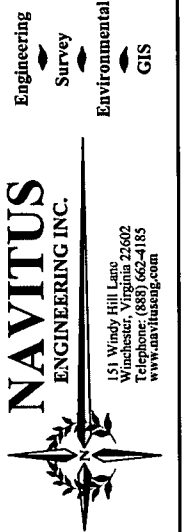
THE DESIGN, CONSTRUCTION, AND REMOVAL OF EMBANKMENTS ASSOCIATED WITH CENTRALIZED FRESHWATER IMPOUNDMENTS FOR OIL AND GAS WELLS MUST BE ACCOMPLISHED IN SUCH A MANNER AS TO PROTECT THE HEALTH AND SAFETY OF THE PEOPLE, THE NATURAL RESOURCES, AND ENVIRONMENT OF THE STATE. THE CENTRALIZED FRESHWATER IMPOUNDMENT EMBANKMENTS SHALL BE DESIGNED, CONSTRUCTED, AND MAINTAINED TO BE STRUCTURALLY SOUND AND REASONABLY PROTECTED FROM UNAUTHORIZED ACTS OF THIRD PARTIES.

- THE FOUNDATION FOR A CENTRALIZED FRESHWATER IMPOUNDMENT EMBANKMENT MUST BE STRIPPED AND GRUBBED TO SOLID GROUND PRIOR TO THE PLACEMENT AND COMPACTION OF EARTHEN FILL MATERIAL. SHOULD SOLID GROUND NOT BE FOUND WITHIN A DEPTH OF 24", CONTRACTOR WILL NOTIFY NAVITUS ENGINEERING AT (888) 682-4186 IMMEDIATELY. NO EMBANKMENT FILL SHALL CONTAIN OR BE PLACED ON FROZEN MATERIAL.
- ANY SPRINGS ENCOUNTERED WITHIN THE FOUNDATION AREA SHALL BE DRAINED TO THE OUTSIDE/DOWNSTREAM TOE OF EMBANKMENT. CONSTRUCTED DRAIN SECTION SHALL BE AN EXCAVATED 2' x 2' TRENCH AND BACK FILLED WITH TYPE A SAND, COMPACTED BY HAND TAMPER. NO GEOTEXTILES SHALL BE USED TO LINE TRENCH. THE LAST 3' OF DRAIN AT THE DOWNSTREAM END SHALL BE CONSTRUCTED WITH ASHITO #8 MATERIAL.
- SOILS FOR EARTHEN EMBANKMENT CONSTRUCTION SHALL BE LIMITED TO TYPES GC, GM, SC, SM, CL, OR ML (ASTM-D2487 - UNIFIED SOILS CLASSIFICATION). SOILS MUST CONTAIN A MINIMUM OF 20% PLUS NO. 200 SIEVE AND BE "WELL GRADED" MATERIAL WITH NO COBBLES OR BOULDER SIZE MATERIAL MIXED WITH THE CLAY. A MINIMUM OF THREE SAMPLES SHALL BE CLASSIFIED.
- ALL FILL AREAS SHALL BE "KEYED IN" AND COMPACTED IN HORIZONTAL LIFTS WITH A MAXIMUM LOOSE LIFT THICKNESS OF 9" AND MAXIMUM PARTICLE SIZE OF LESS THAN 6". ALL FILL SHALL BE COMPACTED BY A VIBRATING SHEEPSFOOT ROLLER TO 95% PER THE STANDARD PROCTOR TEST (ASTM-D998).
- THE PLACEMENT OF ALL FILL MATERIAL SHALL BE FREE OF WOOD, STUMPS AND ROOTS, LARGE ROCKS AND BOULDERS, AND ANY OTHER NONCOMPACTABLE SOIL MATERIAL. THE EMBANKMENT SHALL BE COMPACTED TO A MINIMUM OF VISIBLE NON-MOVEMENT. HOWEVER, THE COMPACTION EFFORT SHALL NOT EXCEED THE OPTIMUM MOISTURE LIMITS.
- THE EMBANKMENT TOP SHALL BE A MINIMUM OF 12' IN WIDTH.
- THE MINIMUM INSIDE AND OUTSIDE EMBANKMENT (FILL) SLOPES SHALL BE 2H:1V, UNLESS OTHERWISE SPECIFIED. THE INSIDE AND OUTSIDE EMBANKMENT (FILL) SLOPES MUST ADD UP TO 5H:1V.
- ALL EXPOSED EMBANKMENT SLOPES, NOT COVERED BY COMPACTED ROCKFILL OR RIP-RAP SHALL BE LINED, FERTILIZED, SEEDED AND MULCHED. PERMANENT VEGETATIVE GROUND COVER IN COMPLIANCE WITH THE WV DEP EROSION AND SEDIMENT CONTROL FIELD MANUAL MUST BE ESTABLISHED UPON THE COMPLETION OF THE CENTRALIZED FRESHWATER IMPOUNDMENT CONSTRUCTION. EMBANKMENTS SHALL BE MAINTAINED WITH A GRASSY VEGETATIVE COVER AND FREE OF BRUSH AND/OR TREES.
- A MINIMUM OF 2' OF FREEBOARD SHALL BE MAINTAINED AT ALL TIMES DURING THE OPERATION OF THE IMPOUNDMENT.
- ALL EMBANKMENT CONSTRUCTION AND COMPACTION TESTING SHALL BE THE RESPONSIBILITY OF THE CONTRACTOR.

## CENTRALIZED FRESHWATER IMPOUNDMENT LINER SYSTEM NOTES

THE DESIGNED CENTRALIZED FRESHWATER IMPOUNDMENT FACILITY SHALL BE FULLY LINED WITH A GEOSYNTHETIC LINER SYSTEM. LINERS SHALL BE INSTALLED IN ACCORDANCE TO MANUFACTURER'S SPECIFICATIONS.

- THE SUB-BASE SHALL BEAR THE WEIGHT OF THE LINER SYSTEM, WATER, AND EQUIPMENT OPERATING ON THE CENTRALIZED FRESHWATER IMPOUNDMENT WITHOUT CAUSING OR ALLOWING A FAILURE OF THE LINER SYSTEM.
- THE SUB-BASE SHALL BE COMPACTED TO ACCOMMODATE POTENTIAL SETTLEMENT WITHOUT DAMAGE TO THE LINER SYSTEM.
- THE UPPER 6" OF THE SUB-BASE SHALL BE COMPACTED TO A STANDARD PROCTOR DENSITY OF AT LEAST 95%.
- THE SUB-BASE SHALL BE HARD, UNIFORM, SMOOTH AND FREE OF DEBRIS, ROCK FRAGMENTS, PLANT MATERIAL, AND OTHER FOREIGN MATERIAL.
- THE SUB-BASE SHALL BE COVERED WITH NON-WOVEN GEOTEXTILE FABRIC TO CUSHION THE PRIMARY LINER AND ALLOW FOR ADEQUATE VENTING BETWEEN THE PRIMARY LINER AND THE SUB-BASE TO PREVENT THE ENTRAPMENT OF GASES BENEATH THE LINER SYSTEM.
- THE CENTRALIZED FRESHWATER IMPOUNDMENT AREA SHALL BE DRAINED AND COMPLETELY DRY PRIOR TO THE PLACEMENT OF THE PRIMARY LINER. THE PRIMARY LINER SHALL MEET ALL WV DEP GUIDELINES FOR MINIMUM THICKNESS AND SHALL PREVENT THE MIGRATION OF WATER THROUGH THE LINER TO THE GREATEST DEGREE THAT IS TECHNOLOGICALLY POSSIBLE.
- THE PRIMARY LINER SHALL FULLY COVER THE BOTTOM, SIDEWALLS, AND ANCHORING TRENCH OF THE CENTRALIZED FRESHWATER IMPOUNDMENT. A TEXTURED LINER IS RECOMMENDED TO PROVIDE A SAFER WALKING SURFACE.
- AN ANCHOR TRENCH SHALL BE EXCAVATED COMPLETELY AROUND THE PERIMETER OF THE CENTRALIZED FRESHWATER IMPOUNDMENT AREA AT THE PLANNED ELEVATION OF THE TOP OF THE LINING. THE TRENCH SHALL BE A MINIMUM 36 INCHES DEEP AND 24 INCHES WIDE.
- ALL ELEMENTS OF THE LINER SYSTEM SHALL BE INSTALLED IN ACCORDANCE WITH THE MANUFACTURER'S SPECIFICATIONS. ALL SEAMS AND SEALS AROUND ANY PROJECTIONS SHALL BE SEALED AND TESTED IN A METHOD APPROVED BY THE MANUFACTURER.
- GAS RELIEF VENTS SHALL BE PROVIDED ALONG THE TOP OF THE LINER AND WITHIN ONE FOOT OF THE PERIMETER OF THE CENTRALIZED FRESHWATER IMPOUNDMENT TO ALLOW GASES TO ESCAPE FROM UNDER THE GEOMEMBRANE. MAXIMUM SPACING FOR VENTS SHALL BE 30 FEET.
- WATER LEVEL MARKINGS SHALL BE CLEARLY PAINTED (6" INCREMENTS) ON THE LINER SYSTEM TO IDENTIFY THE WATER SURFACE ELEVATION.



DATE	REVISION
04/03/2013	UPDATE PER CLIENT REQUEST



CONSTRUCTION AND E&S CONTROL NOTES  
**PEARL JEAN NORTH**  
CENTRALIZED FRESHWATER IMPOUNDMENT  
GRANT DISTRICT  
DODDRIDGE COUNTY, WEST VIRGINIA



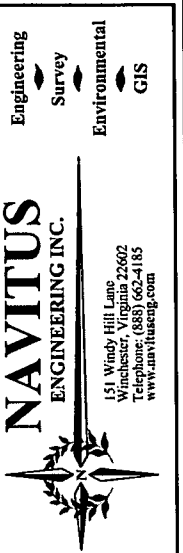
# MATERIAL QUANTITIES

MATERIAL QUANTITIES				
CENTRALIZED IMPOUNDMENT SITE: PEARL JEAN NORTH				
Item Description	Quantity	Unit	Unit Cost	Item Total
1.0 Mobilization				
(Limited to 10% of Total Base Bid)	1.0	LS	\$	\$
2.0 Erosion & Sediment Control				
2.1 Clearing and Grubbing				
2.1.1 Wooded	5.0	AC	\$	\$
2.1.2 Open Field	15.0	AC	\$	\$
2.2 Silt Fence	0.0	LF	\$	\$
2.3 Reinforced Silt Fence	0.0	LF	\$	\$
2.4 Super Silt Fence	0.0	LF	\$	\$
2.5 12" Compost Filter Sock	3,208.0	LF	\$	\$
2.6 18" Compost Filter Sock	496.0	LF	\$	\$
2.7 24" Compost Filter Sock	562.0	LF	\$	\$
2.8 32" Compost Filter Sock	746.0	LF	\$	\$
2.9 18" Compost Sock Diversion	440.0	LF	\$	\$
3.0 Unclassified Earthwork				
3.1 Access Road "A"				
3.1.1 Topsoil Removal to Stockpile (Assume 6" Depth)	3,212.2	CY	\$	\$
3.1.2 Excavation (Cut to Compact Fill)	10,090.0	CY	\$	\$
3.1.3 Excavation (Export to Stockpile)	18,289.6	CY	\$	\$
3.2 Access Road "B"				
3.2.1 Topsoil Removal to Stockpile (Assume 6" Depth)	1,117.0	CY	\$	\$
3.2.2 Excavation (Cut to Compact Fill)	4,842.8	CY	\$	\$
3.2.3 Excavation (Import from Stockpile)	7,195.1	CY	\$	\$
3.3 Access Road "C"				
3.3.1 Topsoil Removal to Stockpile (Assume 6" Depth)	668.7	CY	\$	\$
3.3.2 Excavation (Cut to Compact Fill)	2,742.0	CY	\$	\$
3.3.3 Excavation (Import from Stockpile)	3,306.6	CY	\$	\$
3.4 Tank Staging Area				
3.4.1 Topsoil Removal to Stockpile (Assume 6" Depth)	1,339.0	CY	\$	\$
3.4.2 Excavation (Cut to Compact Fill)	4,348.4	CY	\$	\$
3.4.3 Excavation (Import from Stockpile)	11,540.2	CY	\$	\$
3.5 Centralized Impoundment				
3.5.1 Topsoil Removal to Stockpile (Assume 6" Depth)	2,133.6	CY	\$	\$
3.5.2 Excavation (Cut to Compact Fill)	10,817.8	CY	\$	\$
3.5.3 Excavation (Export to Stockpile)	31,050.3	CY	\$	\$
3.6 Truck Turnaround Pad				
3.6.1 Topsoil Removal to Stockpile (Assume 6" Depth)	353.2	CY	\$	\$
3.6.2 Excavation (Cut to Compact Fill)	696.2	CY	\$	\$
3.6.3 Excavation (Import from Stockpile)	3,583.1	CY	\$	\$
3.7 Excavation/Undiggable Material (Hammering)				
3.8 Excavation/Undiggable Material (Blasting)				

4.0 Stone and Aggregate Surfacing				
4.1 Construction Entrance (3"-4" Stone) 6" Depth	41.7	TONS	\$	\$
4.1.1 Geotextile Fabric (US 200 or Equal)	1,499.6	SF	\$	\$
4.2 Access Road "A" (2"-3" Aggregate) 6" Depth	1,313.4	TONS	\$	\$
4.2.1 Geotextile Fabric (US 200 or Equal)	47,282.4	SF	\$	\$
4.2.2 Clean Rock Fill (2"-4" Coarse Aggregate)	0.0	TONS	\$	\$
4.3 Access Road "B" (2"-3" Aggregate) 6" Depth	475.8	TONS	\$	\$
4.3.1 Geotextile Fabric (US 200 or Equal)	17,128.8	SF	\$	\$
4.3.2 Clean Rock Fill (2"-4" Coarse Aggregate)	0.0	TONS	\$	\$
4.4 Access Road "C" (2"-3" Aggregate) 6" Depth	421.2	TONS	\$	\$
4.4.1 Geotextile Fabric (US 200 or Equal)	15,163.2	SF	\$	\$
4.4.2 Clean Rock Fill (2"-4" Coarse Aggregate)	0.0	TONS	\$	\$
4.5 Tank Staging Area (2"-3" Aggregate) 6" Depth	1,163.9	TONS	\$	\$
4.5.1 Geotextile Fabric (US 200 or Equal)	41,898.6	SF	\$	\$
4.6 Truck Turnaround Pad (2"-3" Aggregate) 6" Depth	326.6	TONS	\$	\$
4.6.1 Geotextile Fabric (US 200 or Equal)	11,755.8	SF	\$	\$
4.7 4" Rip Rap (Outlets/Level Spreaders) 18" Depth	578.7	TONS	\$	\$
4.8 4" Rip Rap (Rock-Lined Ditches) 18" Depth		TONS	\$	\$
4.9 Rock Fill Check Dams (#3 Stone)	30.0	TONS	\$	\$
5.0 Ditch Relief and Drainage Culverts				
5.1 15" CPP (total)	751.0	LF	\$	\$
6.0 Liner System				
6.1 Centralized Impoundment				
6.1.1 Primary Liner (60 Mil Textured)	76,897.0	SF	\$	\$
6.1.2 Non-woven Geotextile Fabric Cushion (16 oz.)	76,897.0	SF	\$	\$
7.0 Miscellaneous				
7.1 Associated Pit Perimeter Safety Fence				
7.1.1 Woven Wire Fence (4' height)	1,156.0	LF	\$	\$
7.1.2 Wood Treated Fence Post (7' length)	116	EA	\$	\$
7.1.3 Gate	1	EA	\$	\$
7.1.4 Emergency Lifeline	1	EA	\$	\$
7.2 Seeding and Mulching				
7.2.1 Temporary Seeding (Vegetation & Mulch)	6.8	AC	\$	\$
7.2.2 Permanent Seeding (Vegetation & Mulch / Fertilizer/ Lime)	17.2	AC	\$	\$
7.2.3 Lime, Fertilizer, Seeding, and Hydro-Mulch w/tack (HYC2 or Equal)		AC	\$	\$

**NOTE:**

1. THE SQUARE FOOTAGE FOR THE GEOTEXTILE FABRIC AND THE LINER SYSTEM DOES NOT ACCOUNT FOR MATERIAL OVERLAP AND WASTE.



DATE	REVISION
04/03/2013	UPDATE PER CLIENT REQUEST

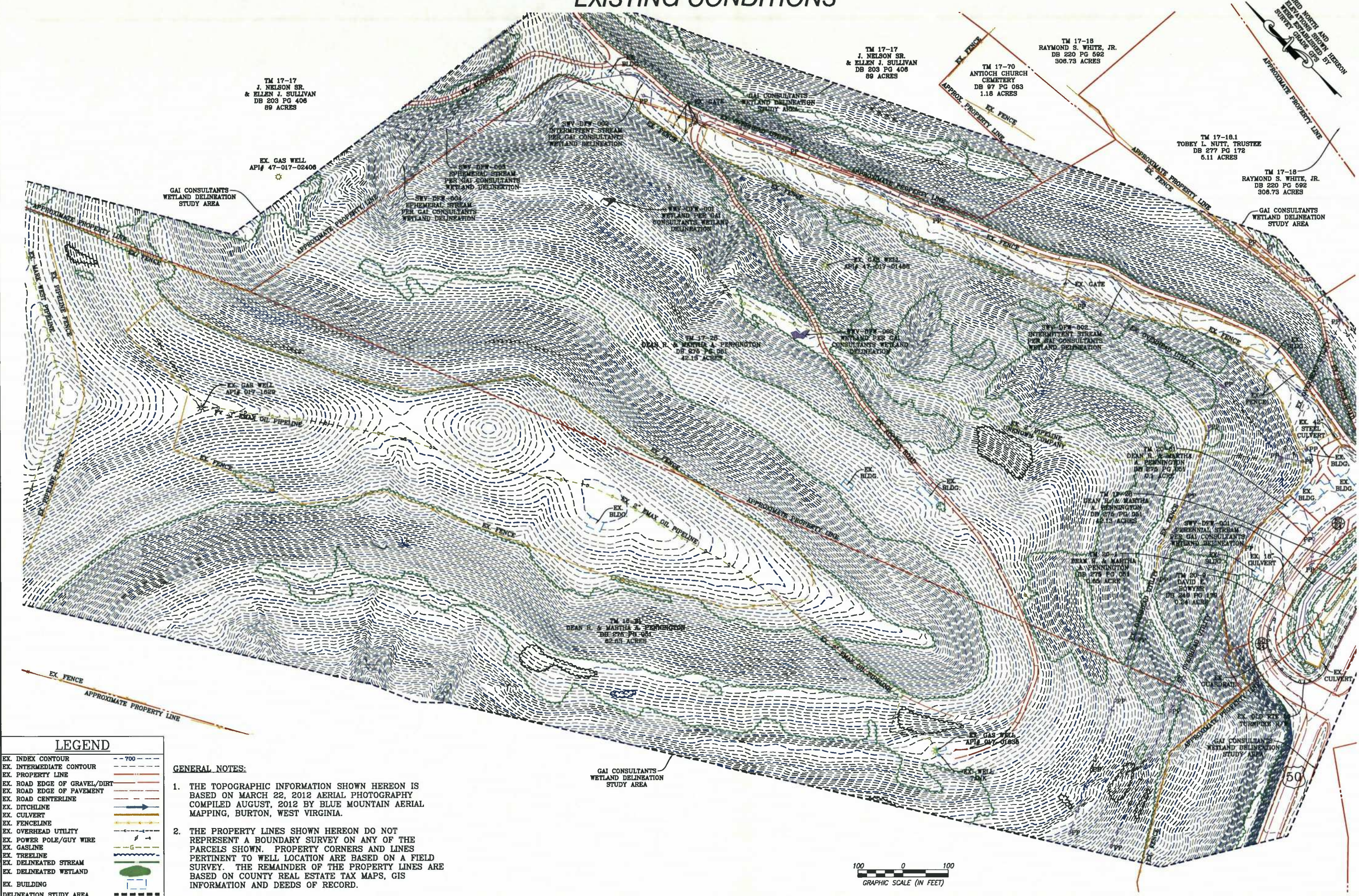


MATERIAL QUANTITIES  
**PEARL JEAN NORTH**  
 CENTRALIZED FRESHWATER IMPOUNDMENT  
 GRANT DISTRICT  
 DODDRIDGE COUNTY, WEST VIRGINIA



DATE: 04/03/2013  
 SCALE: N/A  
 SHEET 3 OF 20

# EXISTING CONDITIONS



LEGEND	
EX. INDEX CONTOUR	--- 700 ---
EX. INTERMEDIATE CONTOUR	--- ---
EX. PROPERTY LINE	---
EX. ROAD EDGE OF GRAVEL/DIRT	---
EX. ROAD EDGE OF PAVEMENT	---
EX. ROAD CENTERLINE	---
EX. DITCHLINE	---
EX. CULVERT	---
EX. FENCELINE	---
EX. OVERHEAD UTILITY	---
EX. POWER POLE/GUY WIRE	---
EX. GASLINE	---
EX. TREELINE	---
EX. DELINEATED STREAM	---
EX. DELINEATED WETLAND	---
EX. BUILDING	---
DELINEATION STUDY AREA	---

- GENERAL NOTES:**
1. THE TOPOGRAPHIC INFORMATION SHOWN HEREON IS BASED ON MARCH 22, 2012 AERIAL PHOTOGRAPHY COMPILED AUGUST, 2012 BY BLUE MOUNTAIN AERIAL MAPPING, BURTON, WEST VIRGINIA.
  2. THE PROPERTY LINES SHOWN HEREON DO NOT REPRESENT A BOUNDARY SURVEY ON ANY OF THE PARCELS SHOWN. PROPERTY CORNERS AND LINES PERTINENT TO WELL LOCATION ARE BASED ON A FIELD SURVEY. THE REMAINDER OF THE PROPERTY LINES ARE BASED ON COUNTY REAL ESTATE TAX MAPS, GIS INFORMATION AND DEEDS OF RECORD.



Engineering  
Survey  
Environmental  
GIS

**NAVITUS**  
ENGINEERING INC.

151 Windy Hill Lane  
Winchester, Virginia 22662  
Telephone: (888) 662-4185  
www.navituseng.com

DATE	REVISION
04/03/2013	UPDATE PER CLIENT REQUEST

**ANTERO**  
RESOURCES

THIS DOCUMENT  
WAS PREPARED  
FOR:

ANTERO RESOURCES  
APPALACHIAN CORP.

EXISTING CONDITIONS

**PEARL JEAN NORTH**  
CENTRALIZED FRESHWATER IMPOUNDMENT  
GRANT DISTRICT  
DODDRIDGE COUNTY, WEST VIRGINIA



DATE: 04/03/2013  
SCALE: 1" = 100'  
SHEET 4 OF 20

# OVERALL PLAN SHEET INDEX & VOLUMES

<b>Access Road "A"</b>	
Topsail Removal:	3,212.2 C.Y.
Total Cut:	26,379.6 C.Y. (Cut/Swell=1)
Total Fill:	10,090.0 C.Y. (Fill Shrink=1)
Cut slope percent grade:	66.67, 50.00 %, slope ratio: 1.5:1, 2:1
Fill slope percent grade:	50.00 %, slope ratio: 2:1
Gravel (6" Depth):	875.6 C.Y.

<b>Access Road "B"</b>	
Topsail Removal:	1,117.0 C.Y.
Total Cut:	4,842.8 C.Y. (Cut/Swell=1)
Total Fill:	12,037.9 C.Y. (Fill Shrink=1)
Cut slope percent grade:	50.00 %, slope ratio: 2:1
Fill slope percent grade:	50.00 %, slope ratio: 2:1
Gravel (6" Depth):	317.2 C.Y.

<b>Access Road "C"</b>	
Topsail Removal:	668.7 C.Y.
Total Cut:	2,742.0 C.Y. (Cut/Swell=1)
Total Fill:	6,048.6 C.Y. (Fill Shrink=1)
Cut slope percent grade:	50.00 %, slope ratio: 2:1
Fill slope percent grade:	50.00 %, slope ratio: 2:1
Gravel (6" Depth):	280.8 C.Y.

<b>Tank Staging Area</b>	
Topsail Removal:	1,339.0 C.Y.
Total Cut:	4,348.4 C.Y. (Cut/Swell=1)
Total Fill:	15,868.6 C.Y. (Fill Shrink=1)
Cut slope percent grade:	50.00 %, slope ratio: 2:1
Fill slope percent grade:	50.00 %, slope ratio: 2:1
Top of Pad Elevation:	1,270.0'
Gravel (6" Depth):	775.9 C.Y.

<b>Centralized Impoundment</b>	
Topsail Removal:	2,133.6 C.Y.
Total Cut:	41,868.1 C.Y. (Cut/Swell=1)
Total Fill:	10,817.8 C.Y. (Fill Shrink=1)
Cut slope percent grade:	50.00 %, slope ratio: 2:1
Fill slope percent grade:	50.00 %, slope ratio: 2:1
Interior slope percent grade:	33.33 %, slope ratio: 3:1
Top of Dam Elevation:	1,220.0'
Bottom of Sump Elevation:	1,200.0'
Incised Elevation:	1,200.0'

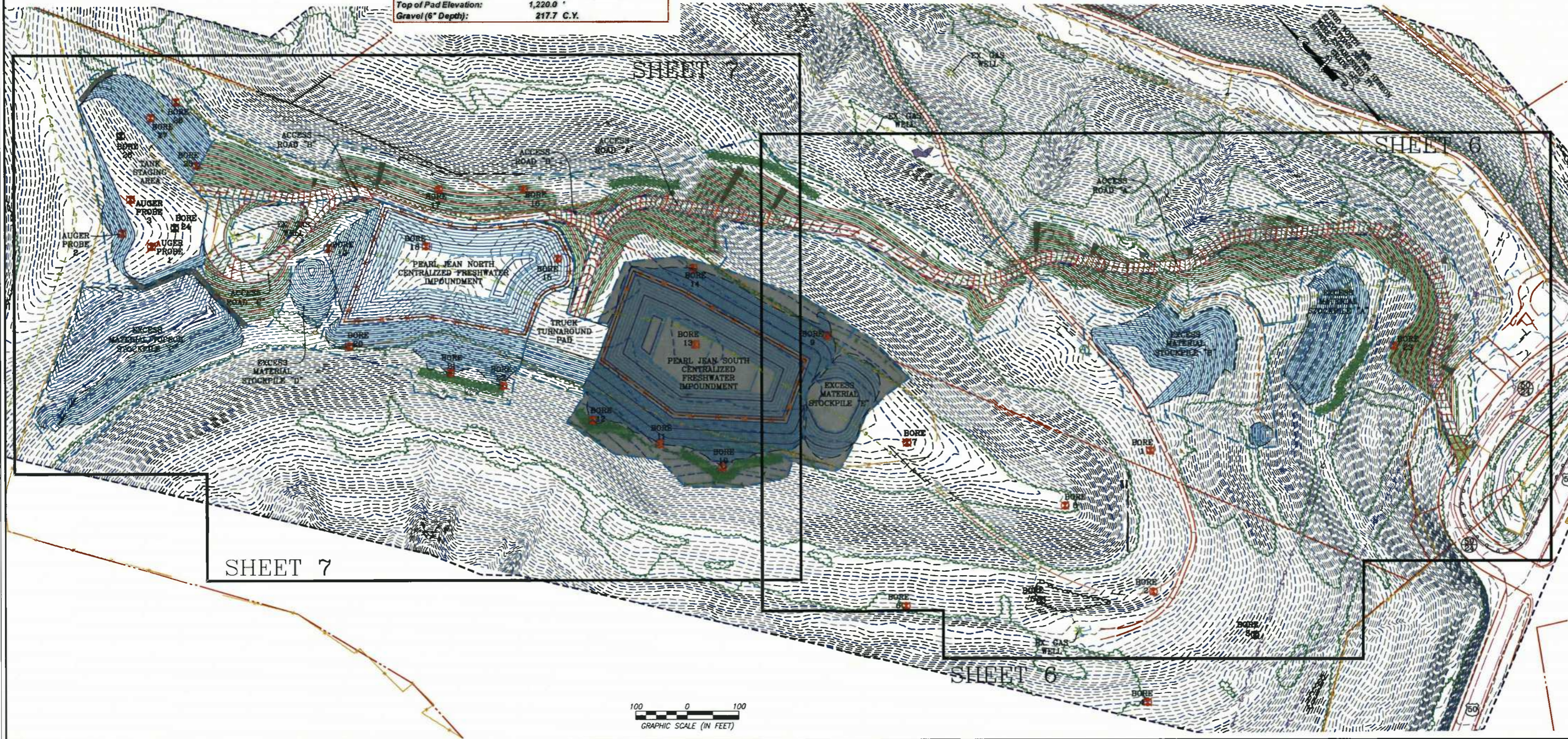
<b>Truck Turnaround Pad</b>	
Topsail Removal:	353.2 C.Y.
Total Cut:	696.2 C.Y. (Cut/Swell=1)
Total Fill:	4,279.3 C.Y. (Fill Shrink=1)
Cut slope percent grade:	50.00 %, slope ratio: 2:1
Fill slope percent grade:	50.00 %, slope ratio: 2:1
Top of Pad Elevation:	1,220.0'
Gravel (6" Depth):	217.7 C.Y.

PEARL JEAN NORTH CENTRALIZED IMPOUNDMENT VOLUME			
Elevation	Barrels	Gallons	Acres-Ft
1200	0.00	0.00	0.0
1201	383	16,084.0	0.0
1202	909	38,176.8	0.1
1203	2,276	95,572.2	0.3
1204	5,257	220,790.4	0.7
1205	9,293	390,311.3	1.2
1206	13,738	576,985.1	1.8
1207	18,604	781,381.9	2.4
1208	23,906	1,004,045.9	3.1
1209	29,656	1,245,547.5	3.8
1210	35,868	1,506,443.6	4.6
1211	42,555	1,787,291.7	5.5
1212	49,730	2,088,668.4	6.4
1213	57,408	2,411,134.2	7.4
1214	65,601	2,755,243.1	8.5
1215	74,323	3,121,575.0	9.6
1216	83,587	3,510,657.9	10.8
1217	93,406	3,923,055.4	12.0
1218	103,793	4,359,295.5	13.4
1219	114,760	4,819,932.1	14.8
1220	126,334	5,306,007.9	16.3

MATERIAL STOCKPILES		
Name	Excess	Topsoil
A	4,000.0	0.0
B	9,500.0	0.0
C	6,400.0	8,900.0
D	1,960.0	0.0
<b>TOTAL</b>	<b>21,860.0</b>	<b>8,900.0</b>

PEARL JEAN NORTH CENTRALIZED IMPOUNDMENT						
Description	Cut (CY)	Fill (CY)	Spoil (CY)	Borrow (CY)	Max. Slope (%)	Length of Slope (FT)
Access Road "A"	26,379.6	10,090.0	16,289.6	0.0	20.0	979.0
Access Road "B"	4,842.8	12,037.9	0.0	7,195.1	19.8	104.0
Access Road "C"	2,742.0	6,048.6	0.0	3,306.6	17.0	75.0
Tank Staging Area	4,348.4	15,888.6	0.0	11,540.2	n/a	n/a
Centralized Impoundment	41,868.1	10,817.8	31,050.3	0.0	n/a	n/a
Truck Turnaround Pad	696.2	4,279.3	0.0	3,583.1	n/a	n/a
Stripped Topsoil (6")	8,823.7	0.0	8,823.7	0.0	n/a	n/a
Material Stockpiles	0.0	30,760.0	0.0	30,760.0	n/a	n/a
<b>Totals</b>	<b>89,700.8</b>	<b>89,922.2</b>	<b>58,163.6</b>	<b>56,385.0</b>	<b>n/a</b>	<b>n/a</b>
Total Spoil (CY) =			-221.4			

THE EARTHWORK QUANTITIES PROVIDED ARE AN ESTIMATE FOR CONSIDERATION. THE QUANTITIES SHOWN ARE CALCULATED USING A 1:1 CUT/SWELL & FILL SHRINK FACTOR. THE QUANTITIES SHOWN MAY BE GREATER OR LESSER THAN ACTUALLY EXCAVATED. THE ENGINEER IS NOT RESPONSIBLE FOR VARIANCES FROM THE ESTIMATED QUANTITIES AND DOES NOT CERTIFY TO THEIR ACCURACY.



**NAVITUS ENGINEERING INC.**  
 Engineering Survey Environmental GIS  
 151 Windy Hill Lane  
 Winchester, Virginia 22602  
 Telephone: (888) 662-4185  
 www.navituseng.com

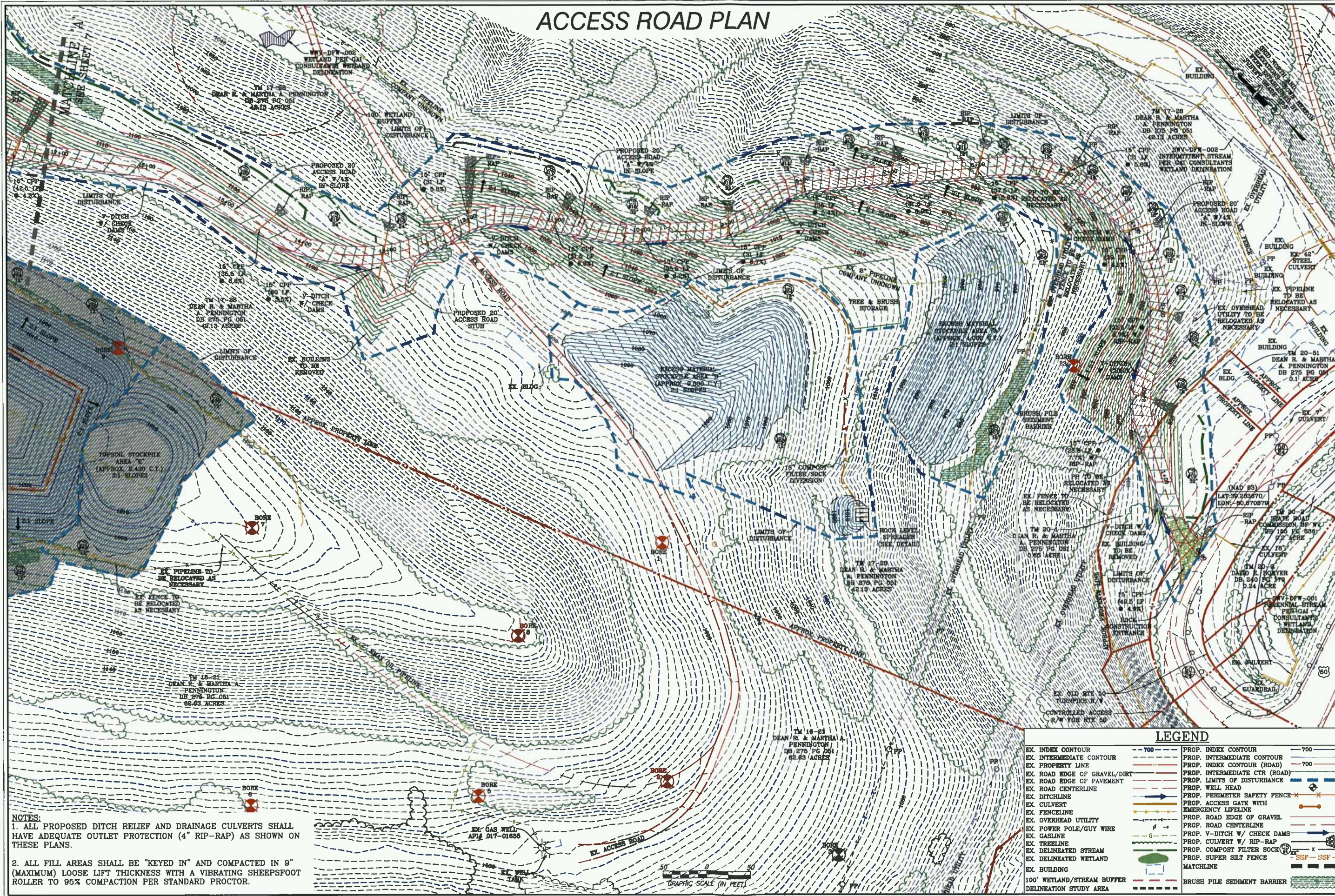
DATE	REVISION
04/03/2013	UPDATE PER CLIENT REQUEST

**ANTERO RESOURCES**  
 THIS DOCUMENT WAS PREPARED FOR:  
 ANTERO RESOURCES  
 APPALACHIAN CORP

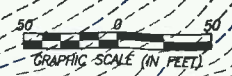
OVERALL PLAN SHEET INDEX & VOLUMES  
**PEARL JEAN NORTH CENTRALIZED FRESHWATER IMPOUNDMENT**  
 GRANT DISTRICT  
 DODDRIDGE COUNTY, WEST VIRGINIA

04/03/2013  
 SCALE: 1" = 100'  
 SHEET 5 OF 20

# ACCESS ROAD PLAN



**NOTES:**  
 1. ALL PROPOSED DITCH RELIEF AND DRAINAGE CULVERTS SHALL HAVE ADEQUATE OUTLET PROTECTION (4" RIP-RAP) AS SHOWN ON THESE PLANS.  
 2. ALL FILL AREAS SHALL BE "KEYED IN" AND COMPACTED IN 9" (MAXIMUM) LOOSE LIFT THICKNESS WITH A VIBRATING SHEEPSFOOT ROLLER TO 95% COMPACTION PER STANDARD PROCTOR.



LEGEND	
EX. INDEX CONTOUR	--- 700 ---
EX. INTERMEDIATE CONTOUR	--- 700 ---
EX. PROPERTY LINE	---
EX. ROAD EDGE OF GRAVEL/DIRT	---
EX. ROAD EDGE OF PAVEMENT	---
EX. ROAD CENTERLINE	---
EX. DITCHLINE	---
EX. CULVERT	---
EX. FENCELINE	---
EX. OVERHEAD UTILITY	---
EX. POWER POLE/GUY WIRE	---
EX. GASLINE	---
EX. TREELINE	---
EX. DELINEATED STREAM	---
EX. DELINEATED WETLAND	---
EX. BUILDING	---
100' WETLAND/STREAM BUFFER DELINEATION STUDY AREA	---
PROP. INDEX CONTOUR	---
PROP. INTERMEDIATE CONTOUR	---
PROP. INDEX CONTOUR (ROAD)	---
PROP. INTERMEDIATE CTR (ROAD)	---
PROP. LIMITS OF DISTURBANCE	---
PROP. WELL HEAD	---
PROP. PERIMETER SAFETY FENCE	---
PROP. ACCESS GATE WITH EMERGENCY LIFELINE	---
PROP. ROAD EDGE OF GRAVEL	---
PROP. ROAD CENTERLINE	---
PROP. V-DITCH W/ CHECK DAMS	---
PROP. CULVERT W/ RIP-RAP	---
PROP. COMPOST FILTER SOCK	---
PROP. SUPER SILT FENCE	---
MATCHLINE	---
BRUSH PILE SEDIMENT BARRIER	---

NAVITUS ENGINEERING INC.  
 151 Windy Hill Lane, #2000  
 Winchester, VA 22603  
 Telephone: (888) 662-4185  
 www.navituseng.com

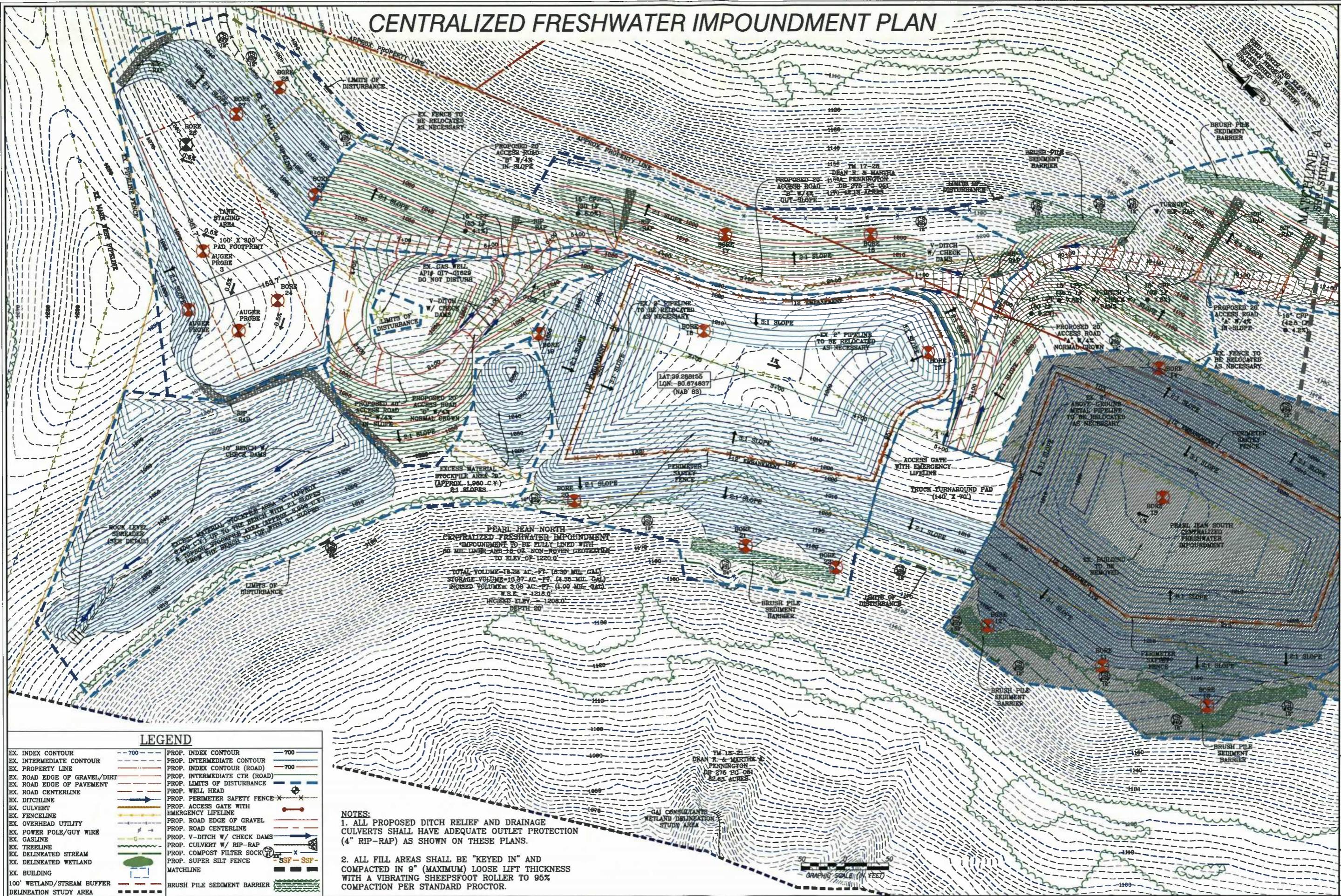
DATE	REVISION
04/03/2013	UPDATE PER CLIENT REQUEST

ANTERO RESOURCES  
 THIS DOCUMENT WAS PREPARED FOR:  
 ANTERO RESOURCES APPALACHIAN CORP.

ACCESS ROAD PLAN  
**PEARL JEAN NORTH**  
 CENTRALIZED FRESHWATER IMPOUNDMENT  
 GRANT DISTRICT  
 DODDRIDGE COUNTY, WEST VIRGINIA

DATE: 04/03/2013  
 SCALE: 1" = 50'  
 SHEET 6 OF 20

# CENTRALIZED FRESHWATER IMPOUNDMENT PLAN



## LEGEND

EX. INDEX CONTOUR	- 700	PROP. INDEX CONTOUR	- 700
EX. INTERMEDIATE CONTOUR	- 700	PROP. INTERMEDIATE CONTOUR	- 700
EX. PROPERTY LINE	- 700	PROP. INDEX CONTOUR (ROAD)	- 700
EX. ROAD EDGE OF GRAVEL/DIRT	- 700	PROP. INTERMEDIATE CTR (ROAD)	- 700
EX. ROAD EDGE OF PAVEMENT	- 700	PROP. LIMITS OF DISTURBANCE	- 700
EX. ROAD CENTERLINE	- 700	PROP. WELL HEAD	- 700
EX. DITCHLINE	- 700	PROP. PERIMETER SAFETY FENCE-X	- 700
EX. CULVERT	- 700	PROP. ACCESS GATE WITH EMERGENCY LIFELINE	- 700
EX. FENCELINE	- 700	PROP. ROAD EDGE OF GRAVEL	- 700
EX. OVERHEAD UTILITY	- 700	PROP. ROAD CENTERLINE	- 700
EX. POWER POLE/GUY WIRE	- 700	PROP. V-DITCH W/ CHECK DAMS	- 700
EX. GASLINE	- 700	PROP. CULVERT W/ RIP-RAP	- 700
EX. TREELINE	- 700	PROP. COMPOST FILTER SOCK	- 700
EX. DELINEATED STREAM	- 700	PROP. SUPER SILT FENCE	- 700
EX. DELINEATED WETLAND	- 700	MATCHLINE	- 700
EX. BUILDING	- 700	BRUSH PILE SEDIMENT BARRIER	- 700
100' WETLAND/STREAM BUFFER DELINEATION STUDY AREA	- 700		- 700

## NOTES:

1. ALL PROPOSED DITCH RELIEF AND DRAINAGE CULVERTS SHALL HAVE ADEQUATE OUTLET PROTECTION (4" RIP-RAP) AS SHOWN ON THESE PLANS.
2. ALL FILL AREAS SHALL BE "KEYED IN" AND COMPACTED IN 9" (MAXIMUM) LOOSE LIFT THICKNESS WITH A VIBRATING SHEEPSFOOT ROLLER TO 95% COMPACTION PER STANDARD PROCTOR.

Engineering Survey Environmental GIS

**NAVITUS ENGINEERING INC.**

151 Woody Hill Lane  
 Westport, VA 22680  
 Telephone: (888) 662-4155  
 www.navituseng.com

DATE	REVISION
04/03/2013	UPDATE PER CLIENT REQUEST

**ANTERO RESOURCES**

THIS DOCUMENT WAS PREPARED FOR:

ANTERO RESOURCES  
 APPALACHIAN CORP.

CENTRALIZED FRESHWATER IMPOUNDMENT PLAN

**PEARL JEAN NORTH**

CENTRALIZED FRESHWATER IMPOUNDMENT

GRANT DISTRICT

DODDRIDGE COUNTY, WEST VIRGINIA

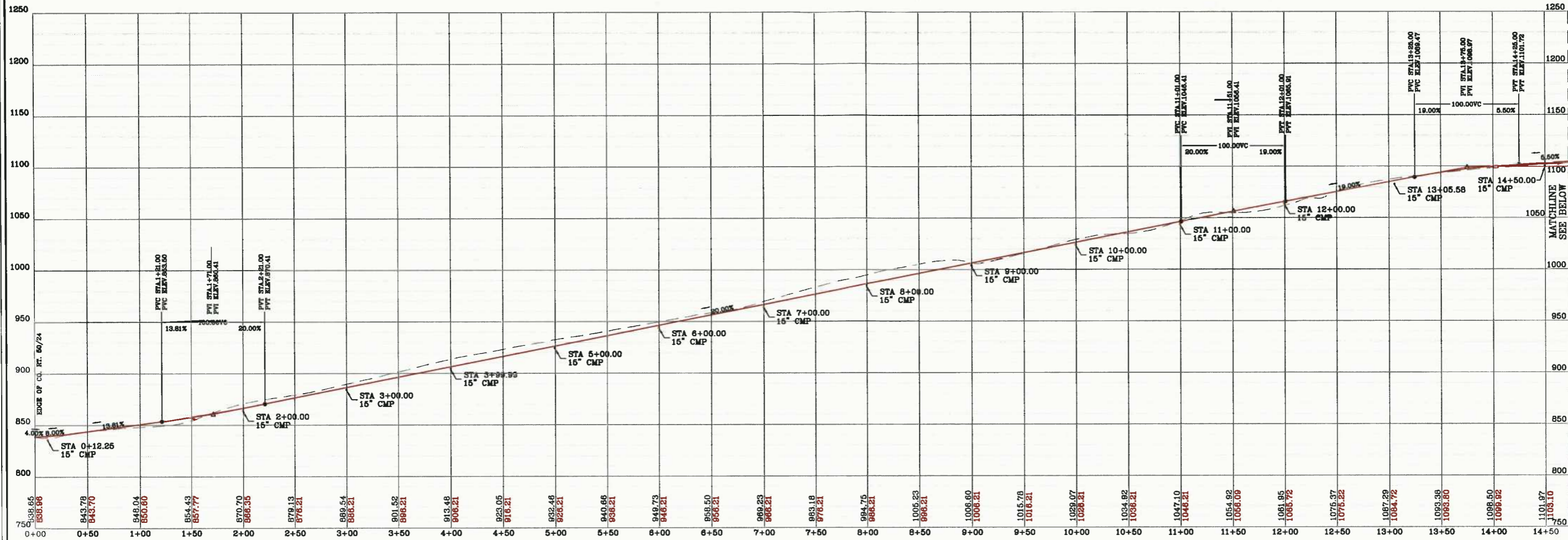


DATE: 04/03/2013

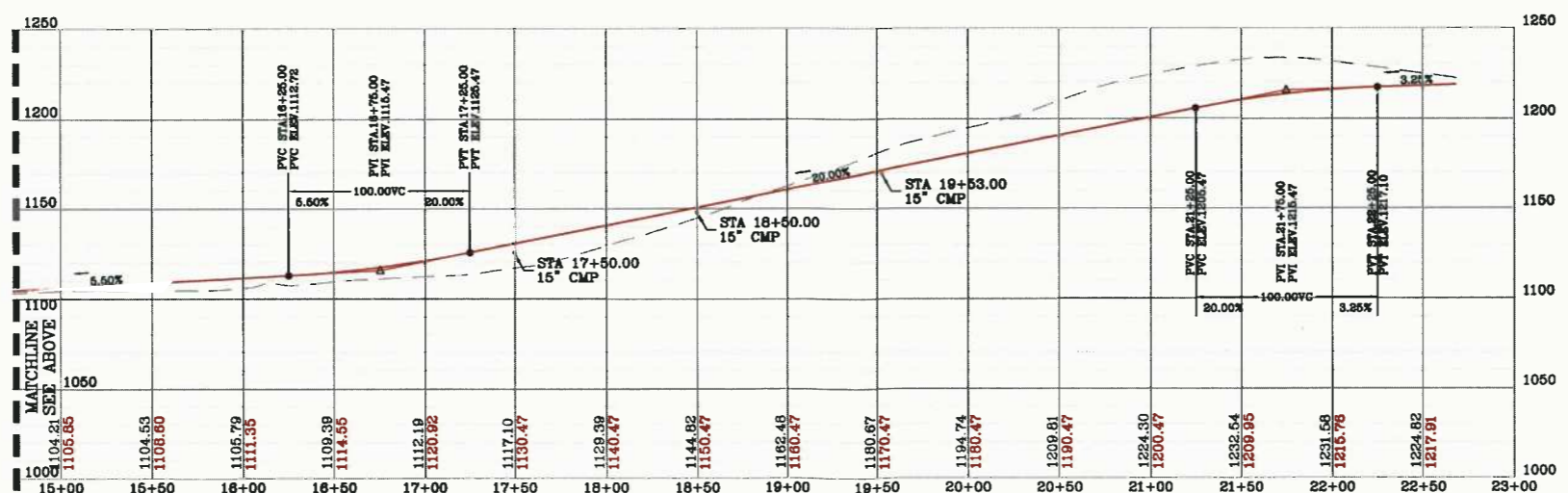
SCALE: 1" = 50'

SHEET 7 OF 20

# ACCESS ROAD PROFILES



**ACCESS ROAD "A" PROFILE**  
SCALE: HORIZ. 1" = 50' VERT. 1" = 50'



**ACCESS ROAD "A" PROFILE**  
SCALE: HORIZ. 1" = 50' VERT. 1" = 50'

LEGEND	
X-SECTION GRID INDEX	---
X-SECTION GRID INTERMEDIATE	---
X-SECTION PROPOSED GRADE	—
X-SECTION EXISTING GRADE	- - -
X-SECTION WATER SURFACE	—
MATCHLINE	

**NAVITUS ENGINEERING INC.**

Engineering Survey Environmental GIS

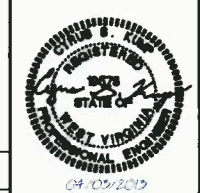
151 Windy Hill Lane  
Waynesboro, VA 22642  
Telephone: (888) 662-4185  
www.navituseng.com

DATE	REVISION
04/03/2013	UPDATE PER CLIENT REQUEST

**ANTERO RESOURCES**

THIS DOCUMENT WAS PREPARED FOR ANTERO RESOURCES APPALACHIAN CORP.

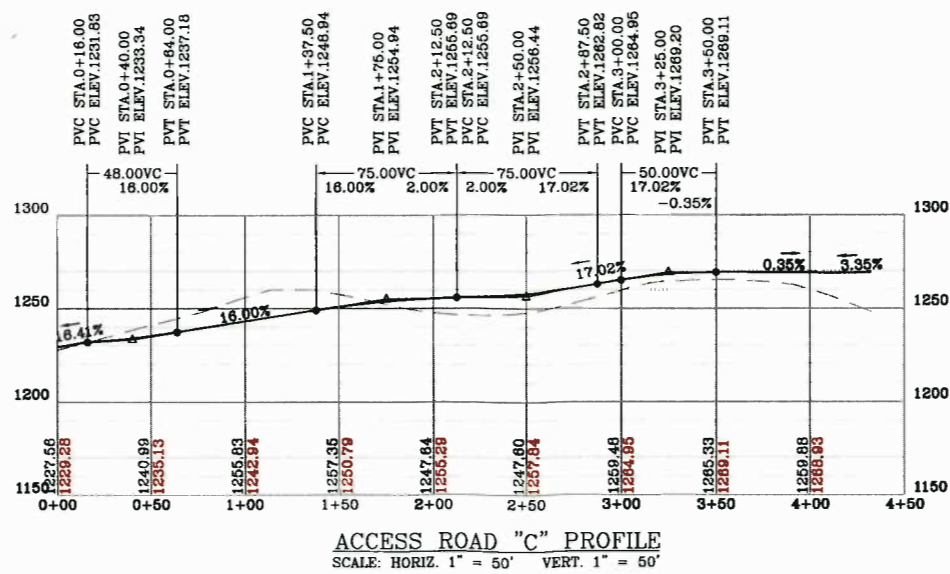
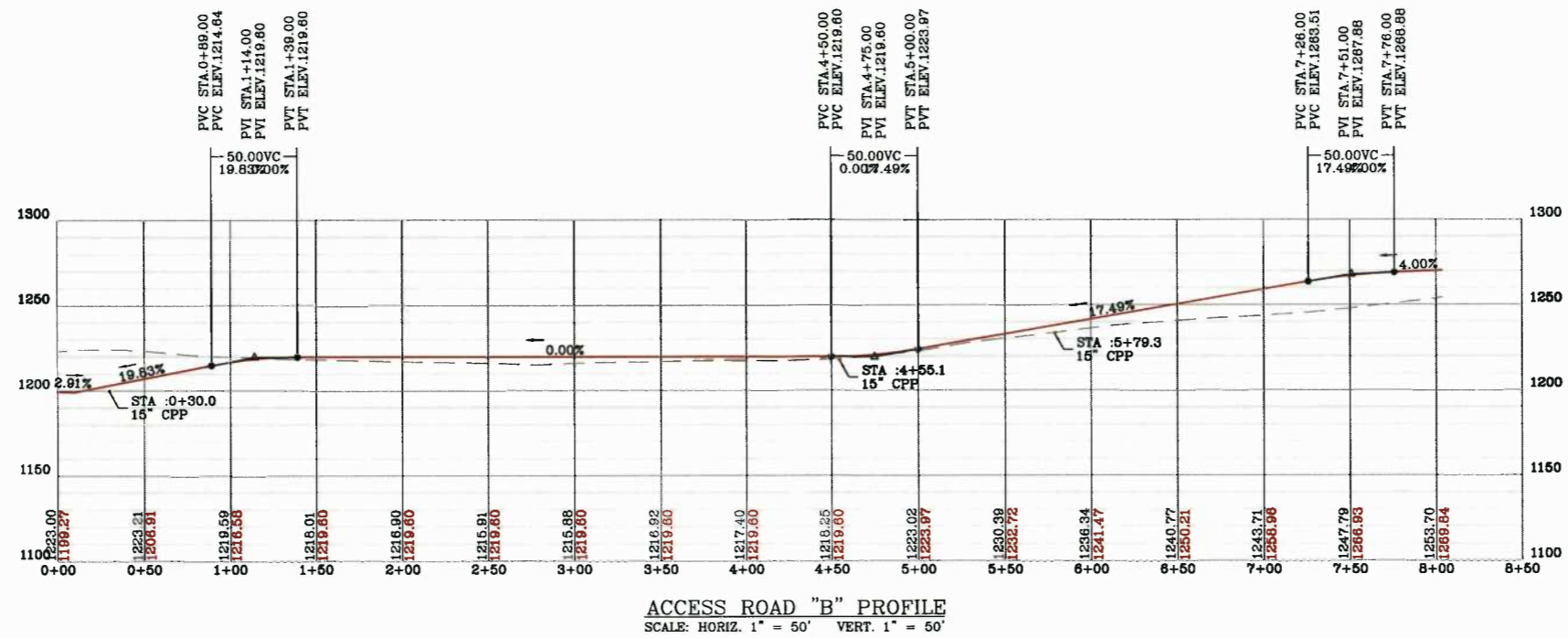
**PEARL JEAN NORTH**  
CENTRALIZED FRESHWATER IMPOUNDMENT  
GRANT DISTRICT  
DODDRIDGE COUNTY, WEST VIRGINIA



DATE: 04/03/2013  
SCALE: AS SHOWN  
SHEET 8 OF 20



# ACCESS ROAD PROFILES



**LEGEND**

X-SECTION GRID INDEX	---
X-SECTION GRID INTERMEDIATE	---
X-SECTION PROPOSED GRADE	---
X-SECTION EXISTING GRADE	---
X-SECTION WATER SURFACE	---
MATCHLINE	---

**NAVITUS ENGINEERING INC.**  
151 Winding Hill Lane  
Winchester, Virginia 22602  
Telephone: (888) 662-4185  
www.navituseng.com

Engineering Survey Environmental GIS

DATE	REVISION
04/03/2013	UPDATE PER CLIENT REQUEST

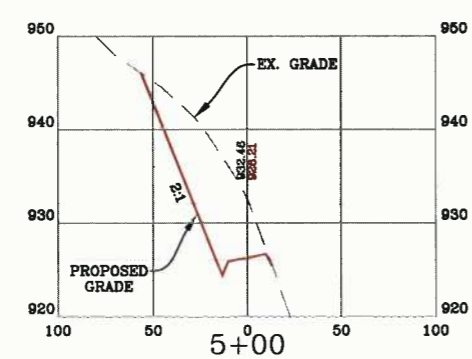
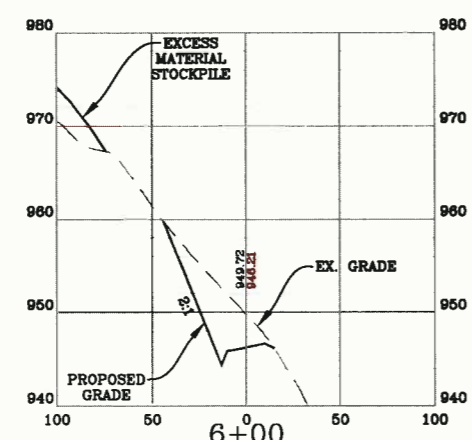
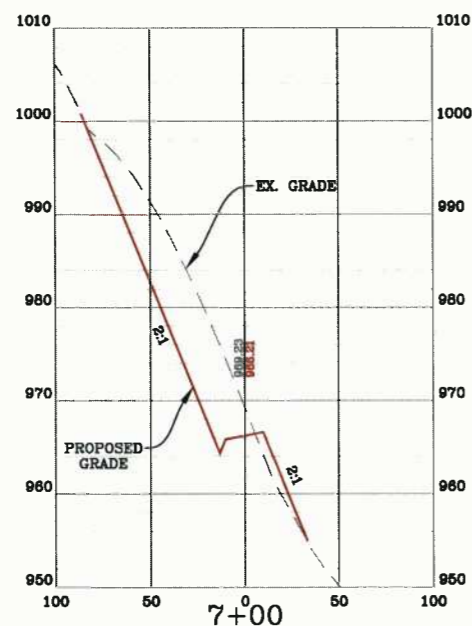
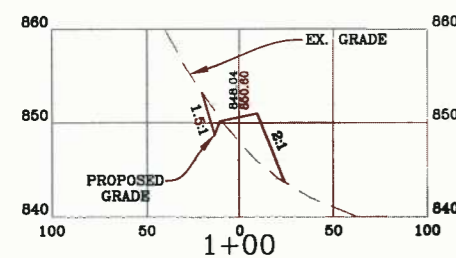
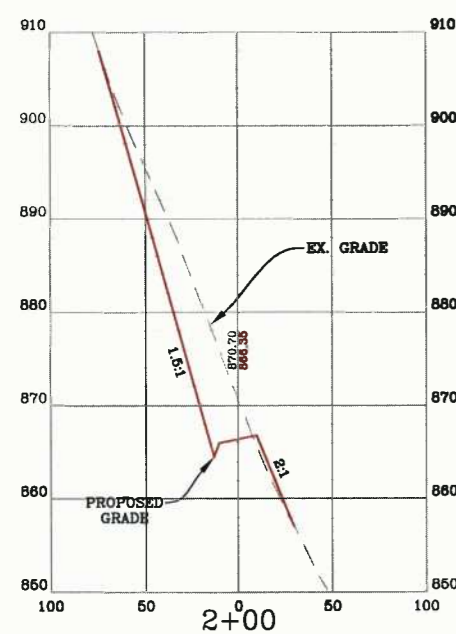
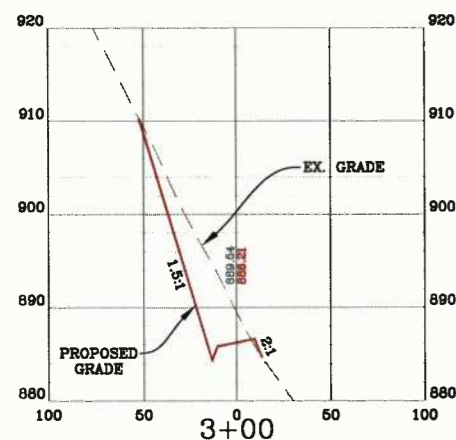
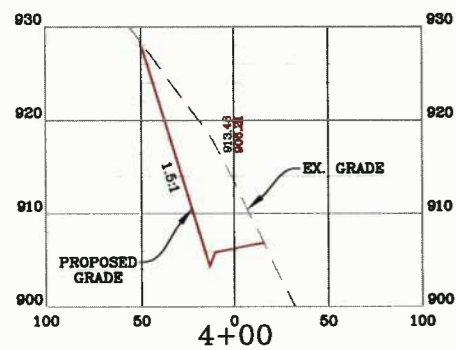
**ANTERO RESOURCES**  
THIS DOCUMENT WAS PREPARED FOR:  
ANTERO RESOURCES  
APPALACHIAN CORP

ACCESS ROAD PROFILES  
**PEARL JEAN NORTH**  
CENTRALIZED FRESHWATER IMPOUNDMENT  
GRANT DISTRICT  
DODDRIDGE COUNTY, WEST VIRGINIA

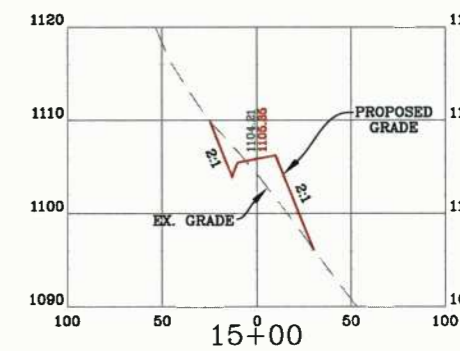
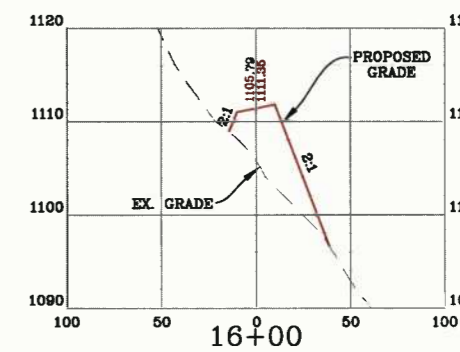
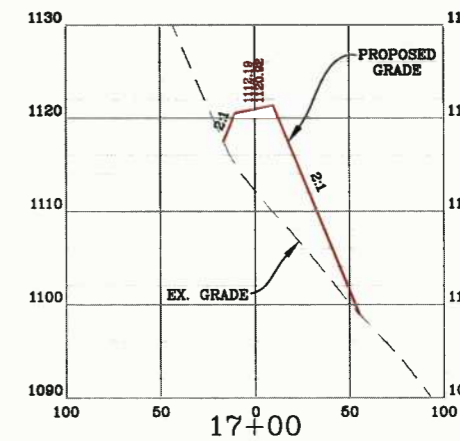
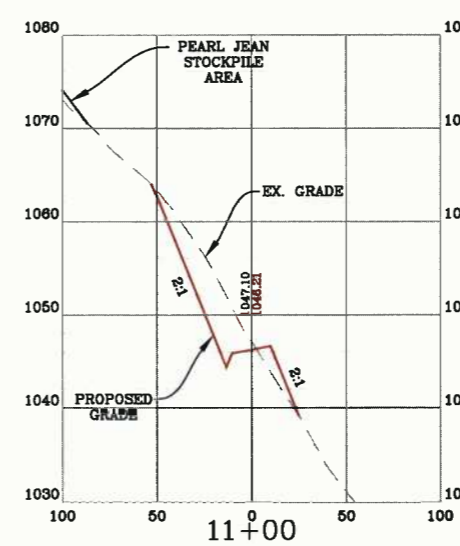
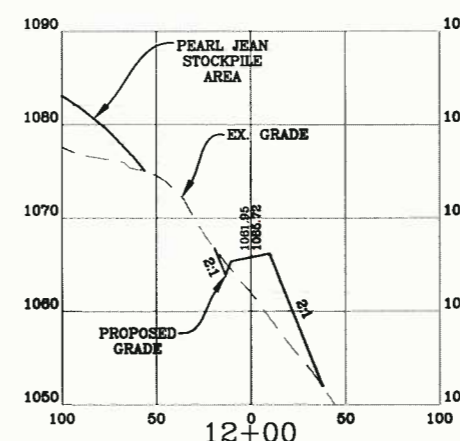
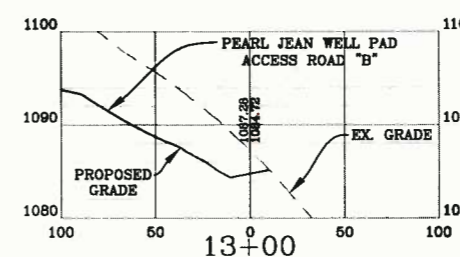
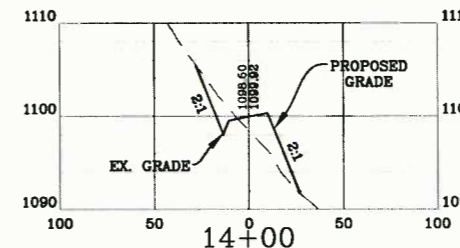
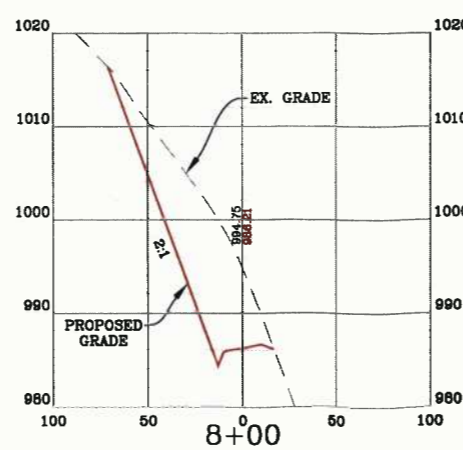
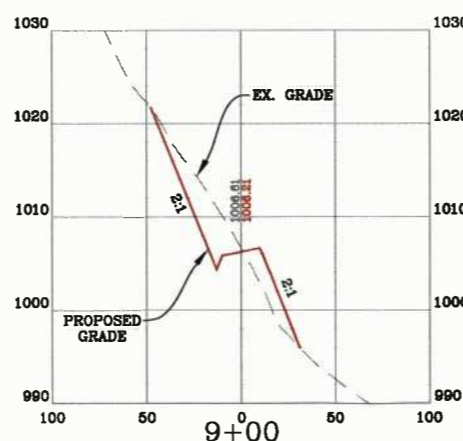
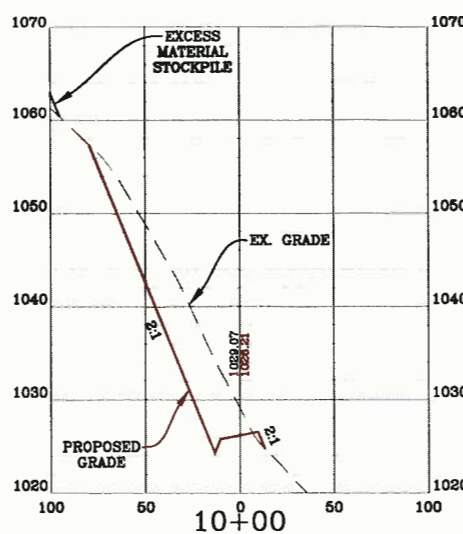


DATE: 04/03/2013  
SCALE: AS SHOWN  
SHEET 9 OF 20

# ACCESS ROAD SECTIONS



ACCESS ROAD "A" CROSS-SECTIONS  
SCALE: HORIZ. 1" = 50' VERT. 1" = 10'



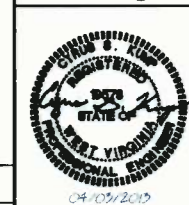
NOTE:  
1. ALL CUT & FILL SLOPES ALONG THE ACCESS ROAD SHALL BE 2:1 UNLESS STATED OTHERWISE.

LEGEND	
X-SECTION GRID INDEX	---
X-SECTION GRID INTERMEDIATE	---
X-SECTION PROPOSED GRADE	—
X-SECTION EXISTING GRADE	- - -
X-SECTION WATER SURFACE	—
X-SECTION MATCHLINE	—

DATE	REVISION
04/03/2013	UPDATE PER CLIENT REQUEST

ANTERO RESOURCES  
THIS DOCUMENT  
WAS PREPARED  
FOR:  
ANTERO RESOURCES  
APPALACHIAN CORP.

ACCESS ROAD SECTIONS  
**PEARL JEAN NORTH**  
CENTRALIZED FRESHWATER IMPOUNDMENT  
GRANT DISTRICT  
DODDRIDGE COUNTY, WEST VIRGINIA

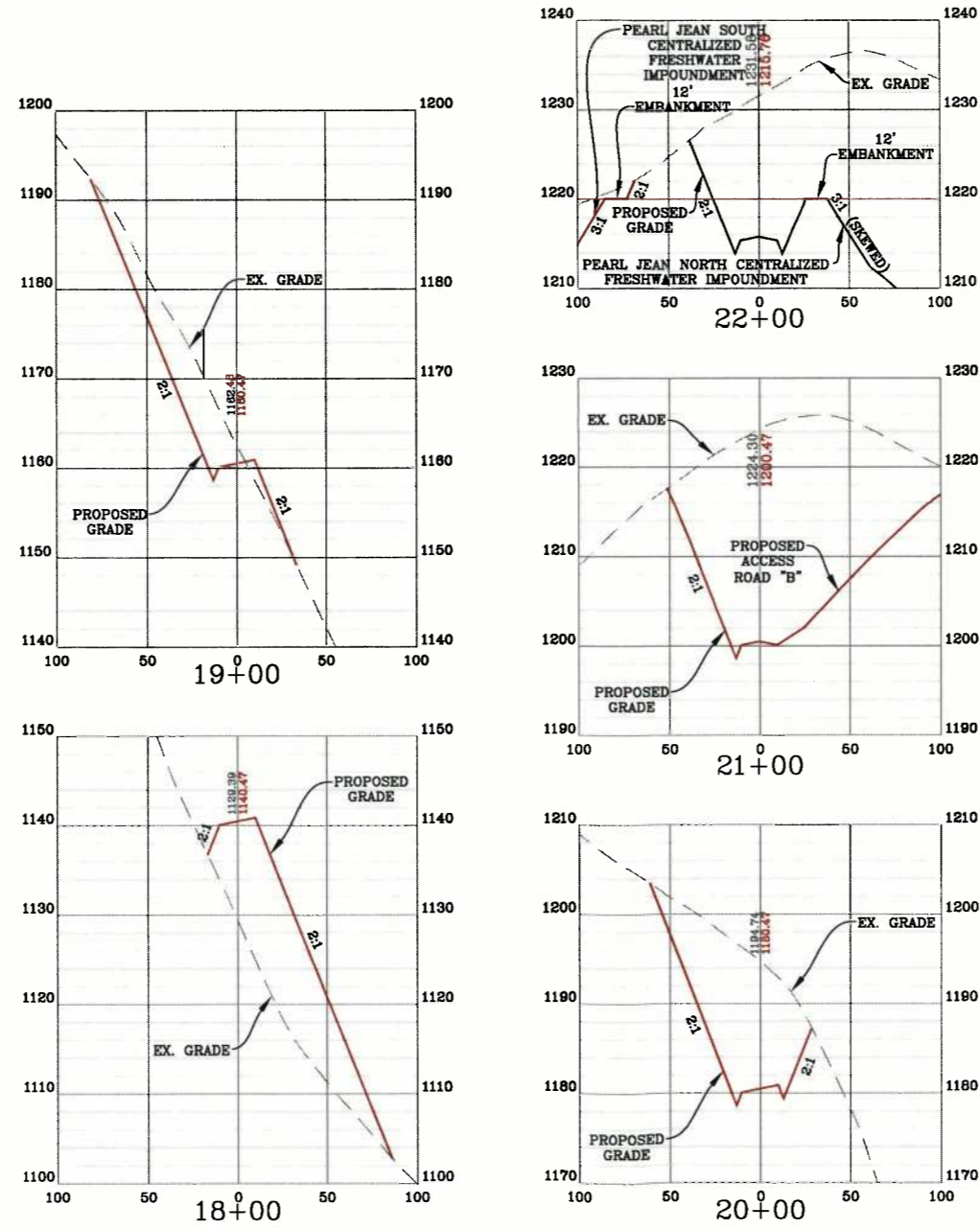


DATE: 04/03/2013  
SCALE: AS SHOWN  
SHEET 10 OF 20

Engineering Survey Environmental GIS  
**NAVITUS ENGINEERING INC.**  
151 Windy Hill Lane  
Windsor, Virginia 22602  
Telephone: (888) 662-4185  
www.navitasag.com

# ACCESS ROAD SECTIONS

**ACCESS ROAD "A" CROSS-SECTIONS**  
SCALE: HORIZ. 1" = 50' VERT. 1" = 10'



**NOTE:**  
1. ALL CUT & FILL SLOPES ALONG THE ACCESS ROAD SHALL BE 2:1 UNLESS STATED OTHERWISE.

LEGEND	
X-SECTION GRID INDEX	---
X-SECTION GRID INTERMEDIATE	---
X-SECTION PROPOSED GRADE	—
X-SECTION EXISTING GRADE	- - -
X-SECTION WATER SURFACE	—
MATCHLINE	

**NAVITUS ENGINEERING INC.**  
151 Windy Hill Lane  
Winchester, Virginia 22602  
Telephone: (888) 662-4185  
www.navituseng.com

Engineering Survey Environmental GIS

DATE	REVISION
04/03/2013	UPDATE PER CLIENT REQUEST

**ANTERO RESOURCES**  
THIS DOCUMENT WAS PREPARED FOR:  
ANTERO RESOURCES APPALACHIAN CORP

ACCESS ROAD SECTIONS  
**PEARL JEAN NORTH**  
CENTRALIZED FRESHWATER IMPOUNDMENT  
GRANT DISTRICT  
DODDRIDGE COUNTY, WEST VIRGINIA



DATE: 04/03/2013  
SCALE: AS SHOWN  
SHEET 11 OF 20

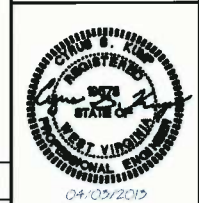
# ACCESS ROAD SECTIONS

DATE	REVISION	UPDATE PER CLIENT REQUEST
04/03/2013		

ANTERO RESOURCES  
 THIS DOCUMENT  
 WAS PREPARED  
 FOR:  
 ANTERO RESOURCES  
 APPALACHIAN CORP.

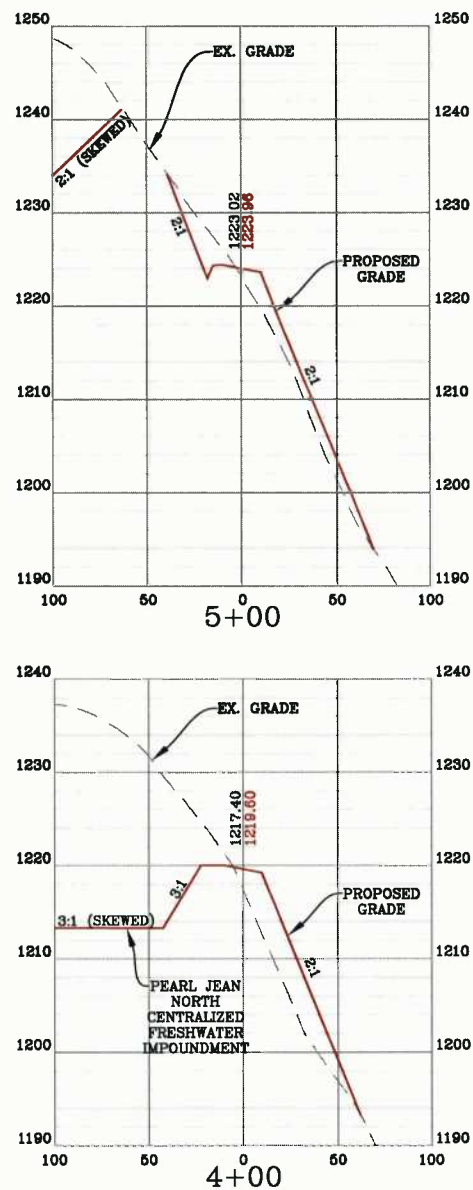
ACCESS ROAD SECTIONS

**PEARL JEAN NORTH**  
 CENTRALIZED FRESHWATER IMPOUNDMENT  
 GRANT DISTRICT  
 DODDRIDGE COUNTY, WEST VIRGINIA

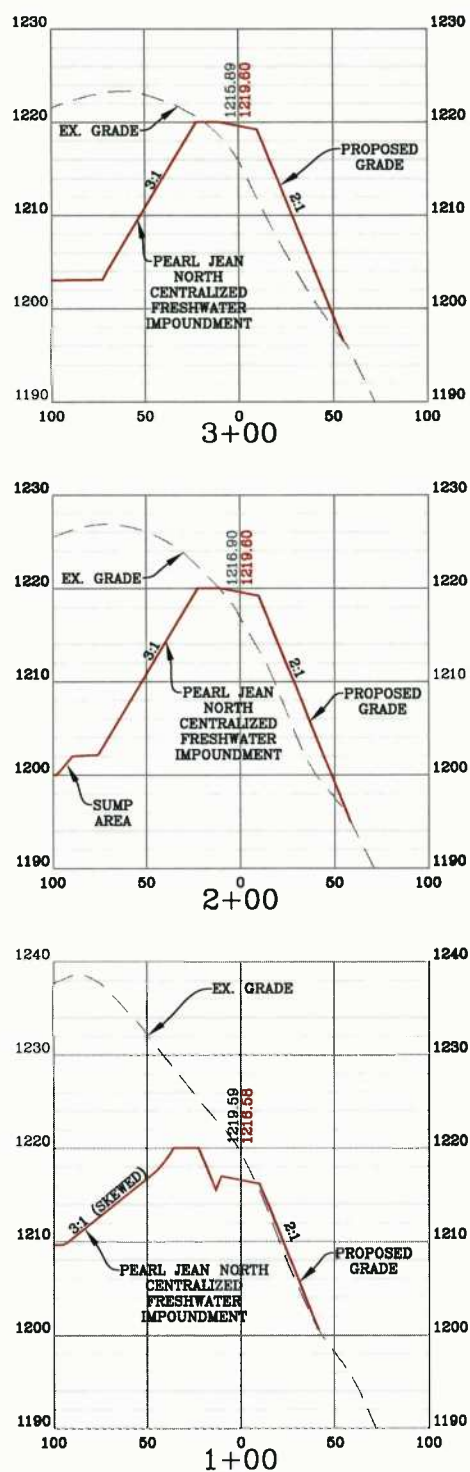
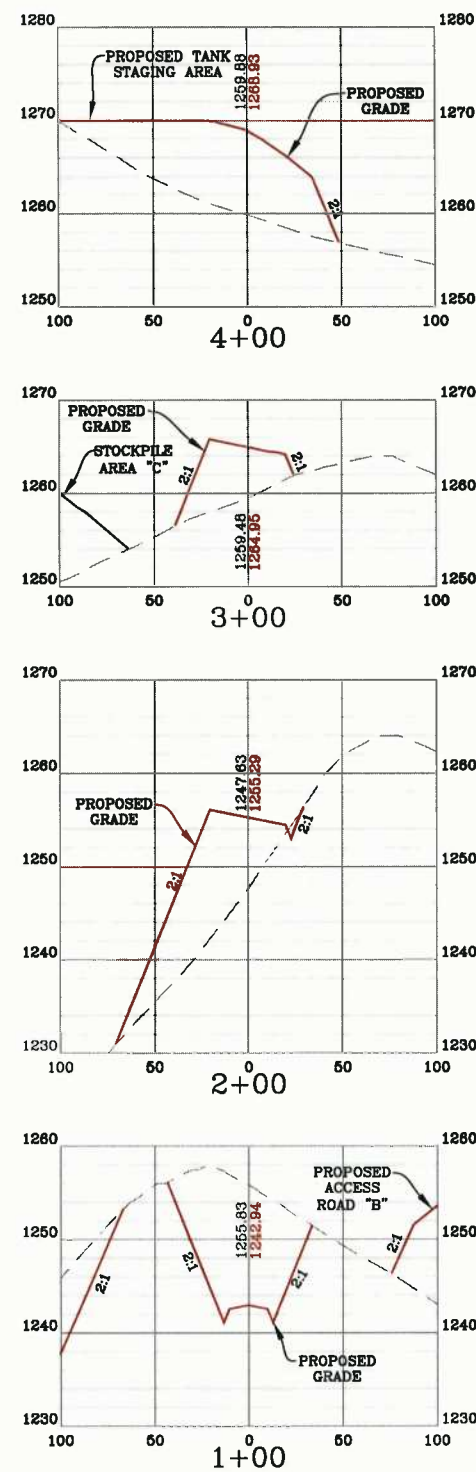


DATE: 04/03/2013  
 SCALE: AS SHOWN  
 SHEET 12 OF 20

**ACCESS ROAD "B" CROSS-SECTIONS**  
 SCALE: HORIZ. 1" = 50' VERT. 1" = 10'



**ACCESS ROAD "C" CROSS-SECTIONS**  
 SCALE: HORIZ. 1" = 50' VERT. 1" = 10'



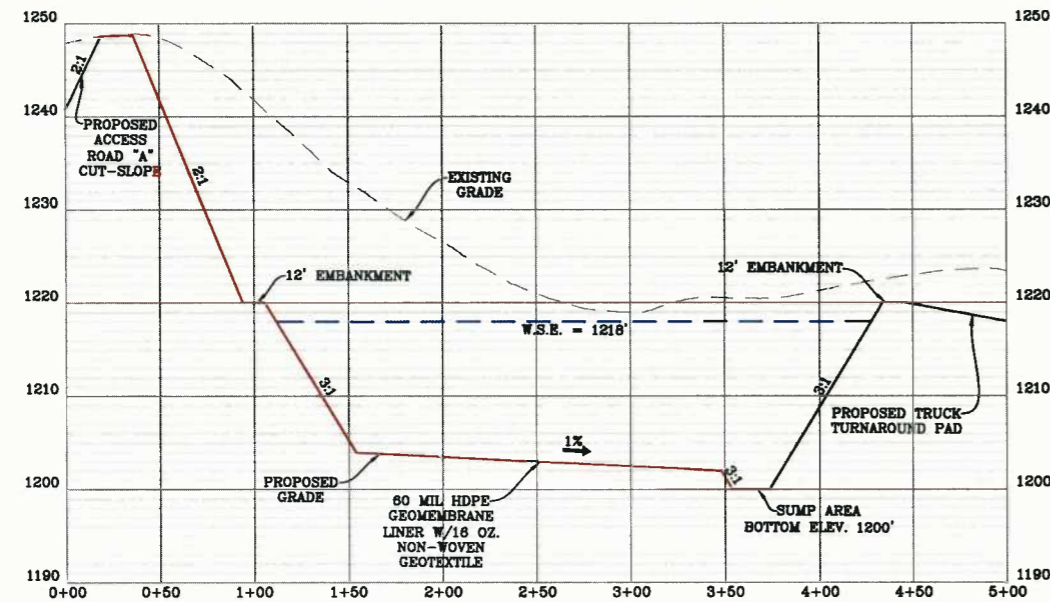
**NOTE:**  
 1. ALL CUT & FILL SLOPES ALONG  
 THE ACCESS ROAD SHALL BE 2:1  
 UNLESS STATED OTHERWISE.

**LEGEND**

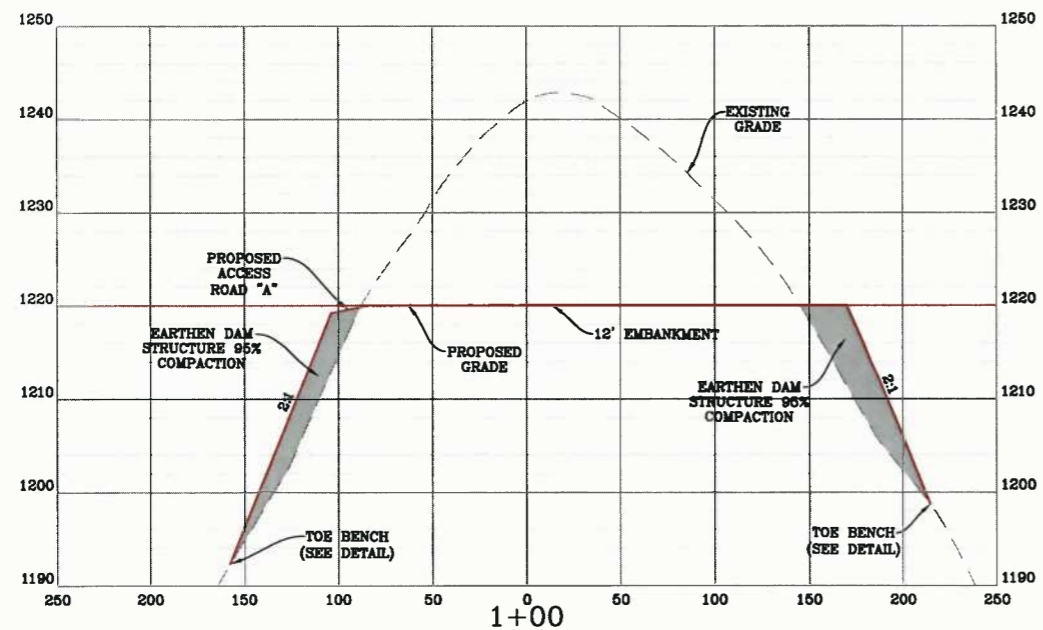
X-SECTION GRID INDEX	---
X-SECTION GRID INTERMEDIATE	---
X-SECTION PROPOSED GRADE	—
X-SECTION EXISTING GRADE	- - -
X-SECTION WATER SURFACE	—
MATCHLINE	

# CENTRALIZED FRESHWATER IMPOUNDMENT SECTIONS

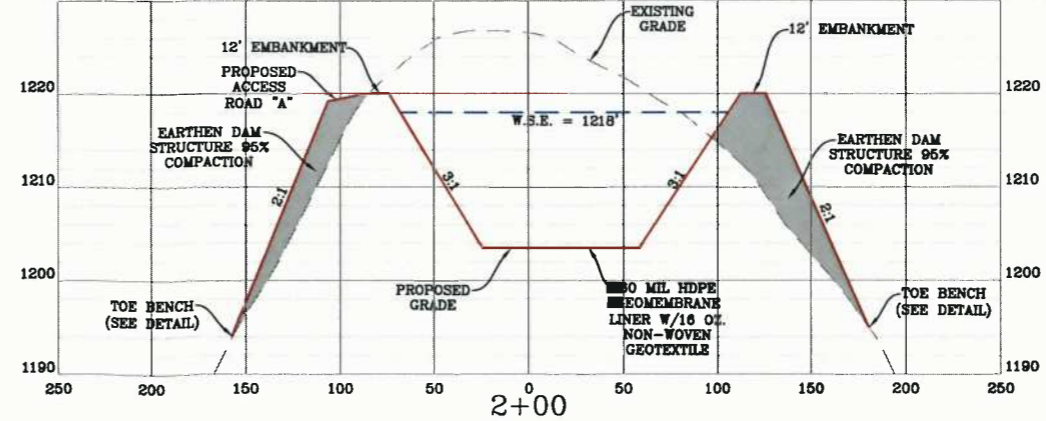
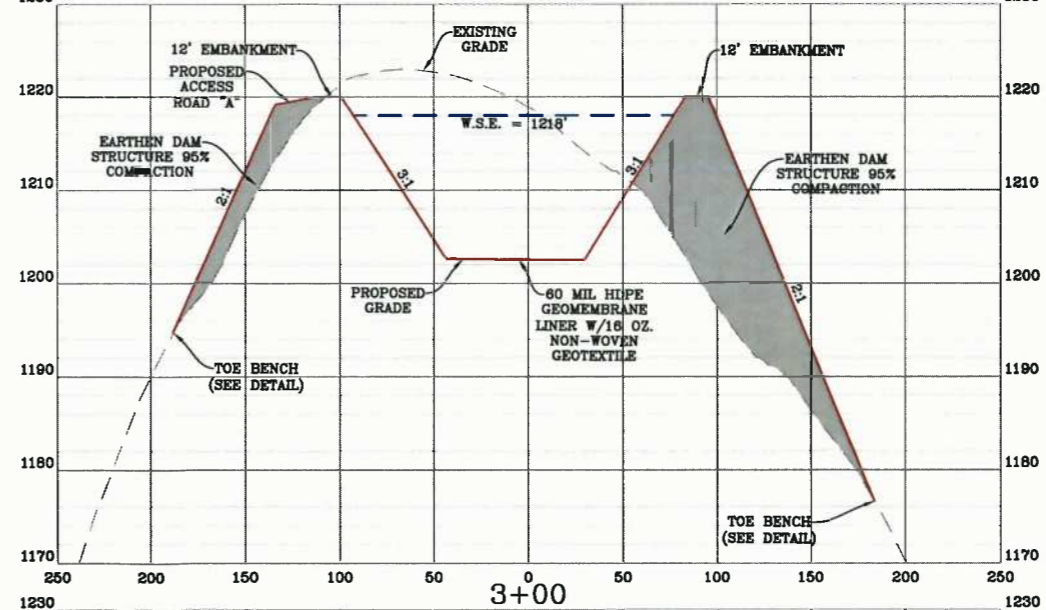
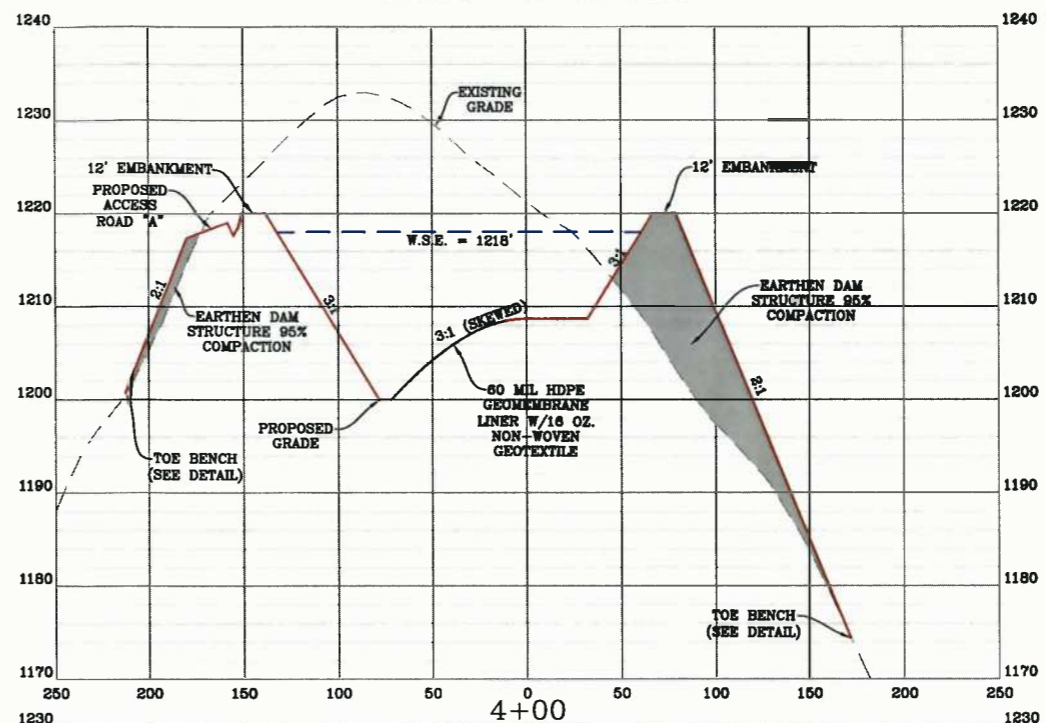
PEARL JEAN NORTH CENTRALIZED FRESHWATER IMPOUNDMENT CROSS-SECTION "A-A"  
SCALE: HORIZ. 1" = 50' VERT. 1" = 10'



PEARL JEAN NORTH CENTRALIZED FRESHWATER IMPOUNDMENT  
CROSS-SECTIONS ALONG BASELINE "A-A"  
SCALE: HORIZ. 1" = 50' VERT. 1" = 10'



PEARL JEAN NORTH CENTRALIZED FRESHWATER IMPOUNDMENT  
CROSS-SECTIONS ALONG BASELINE "A-A"  
SCALE: HORIZ. 1" = 50' VERT. 1" = 10'



NOTE:  
1. ALL FILL AREAS SHALL BE "KEYED IN" AND COMPACTED IN 9" (MAXIMUM) LOOSE LIFT THICKNESS WITH A VIBRATING SHEEPSFOOT ROLLER TO 95% COMPACTION PER STANDARD PROCTOR.

LEGEND	
X-SECTION GRID INDEX	---
X-SECTION GRID INTERMEDIATE	---
X-SECTION PROPOSED GRADE	---
X-SECTION EXISTING GRADE	---
X-SECTION WATER SURFACE	---
MATCHLINE	---

DATE	REVISION
04/03/2013 <td>UPDATE PER CLIENT REQUEST </td>	UPDATE PER CLIENT REQUEST

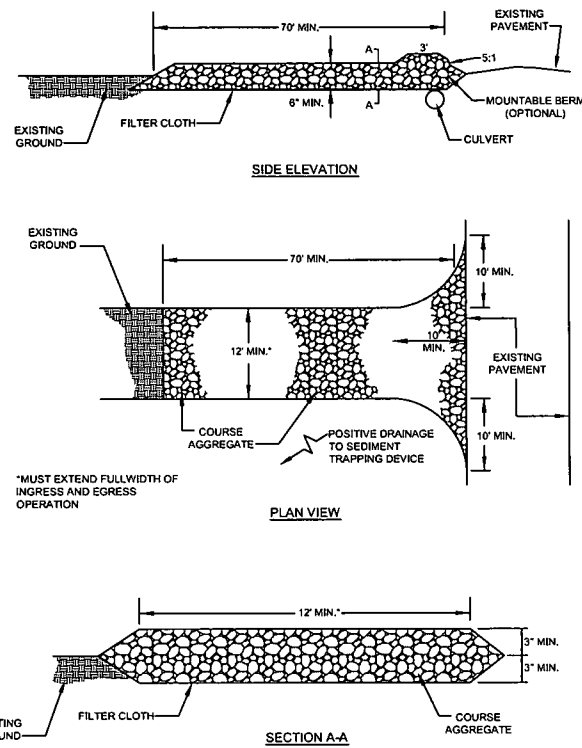
ANTERO RESOURCES  
THIS DOCUMENT  
WAS PREPARED  
FOR:  
ANTERO RESOURCES  
APPALACHIAN CORP

CENTRALIZED FRESHWATER IMPOUNDMENT SECTIONS  
**PEARL JEAN NORTH**  
CENTRALIZED FRESHWATER IMPOUNDMENT  
GRANT DISTRICT  
DODDRIDGE COUNTY, WEST VIRGINIA

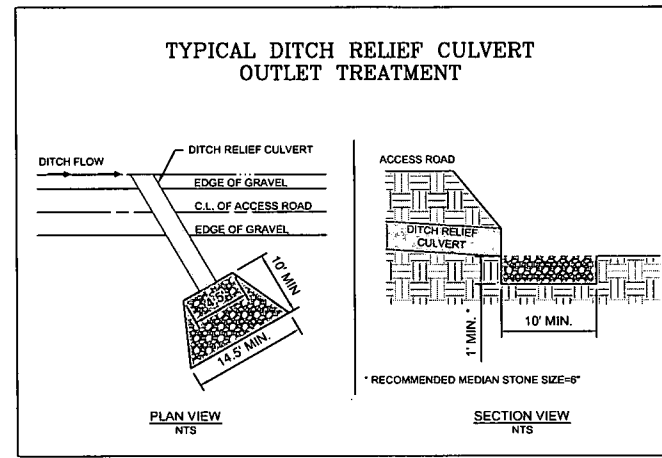


FIGURE 3.02.1

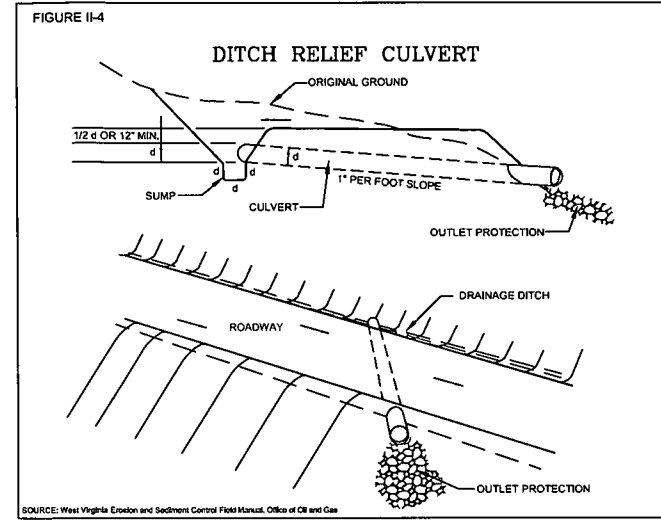
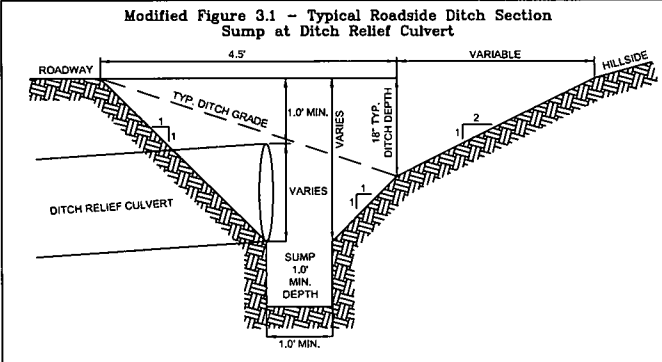
STONE CONSTRUCTION ENTRANCE



SOURCE: ADAPTED FROM THE 1983 MARYLAND STANDARDS FOR SOIL EROSION AND SEDIMENT CONTROL AND VA DSWC



**NOTE:**  
 ALL DITCH LINE PROTECTION SHALL BE INSTALLED AS RECOMMENDED IN THE WEST VIRGINIA EROSION AND SEDIMENT CONTROL BEST MANAGEMENT PRACTICE (BMP) MANUAL. DITCH LINE PROTECTION SHALL BE BASED ON THE FOLLOWING GRADES:  
 1. LESS THAN 3% - GRASSED  
 2. 3-8% - GRASS WITH ROLLED EROSION CONTROL PRODUCTS (RECP)  
 3. GREATER THAN 8% - RIPRAP OR EQUIVALENT GEOTEXTILE  
 IF HIGH EROSION SOILS ARE ENCOUNTERED DURING CONSTRUCTION, THE ENGINEER SHOULD BE CONTACTED FOR FURTHER EVALUATION.



SOURCE: WEST VIRGINIA EROSION AND SEDIMENT CONTROL FIELD MANUAL, OFFICE OF OIL AND GAS

Table II-5  
Pipe Sizes for Culverts Across Roads

Drainage Area (Ac)	Pipe Diameter (In)	Pipe Capacity (Cfs)
10	15	5
20	18	9
30	21	12
50	24	16
80	27	24
100	30	28
300	36	60
500	42	85

Table II-6  
Spacing of Culverts

Road Grade %	Distance (Ft)
2-5	500-300
6-10	300-200
11-15	200-100
16-20	100

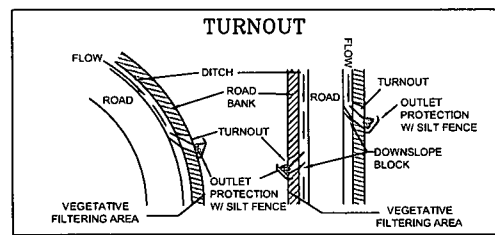
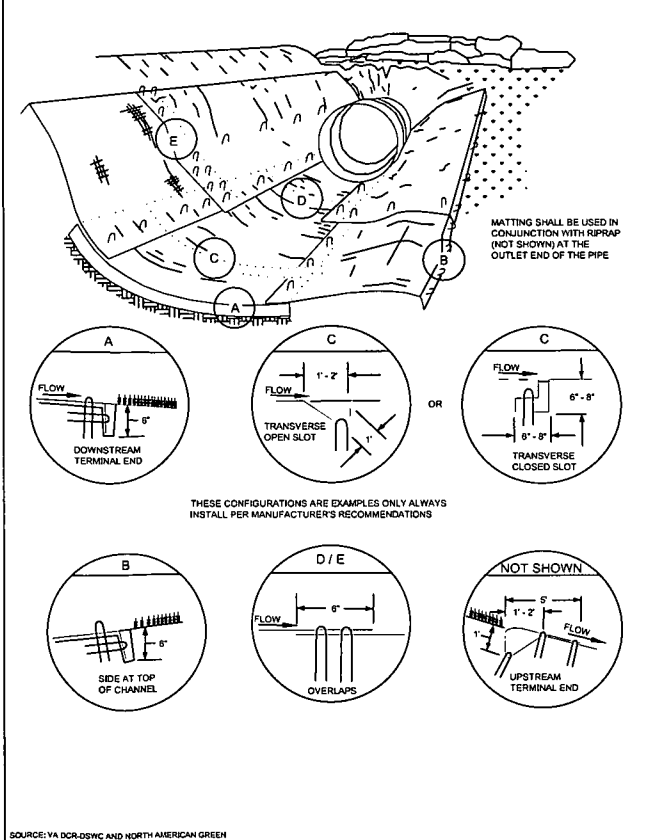


FIGURE 3.13.1

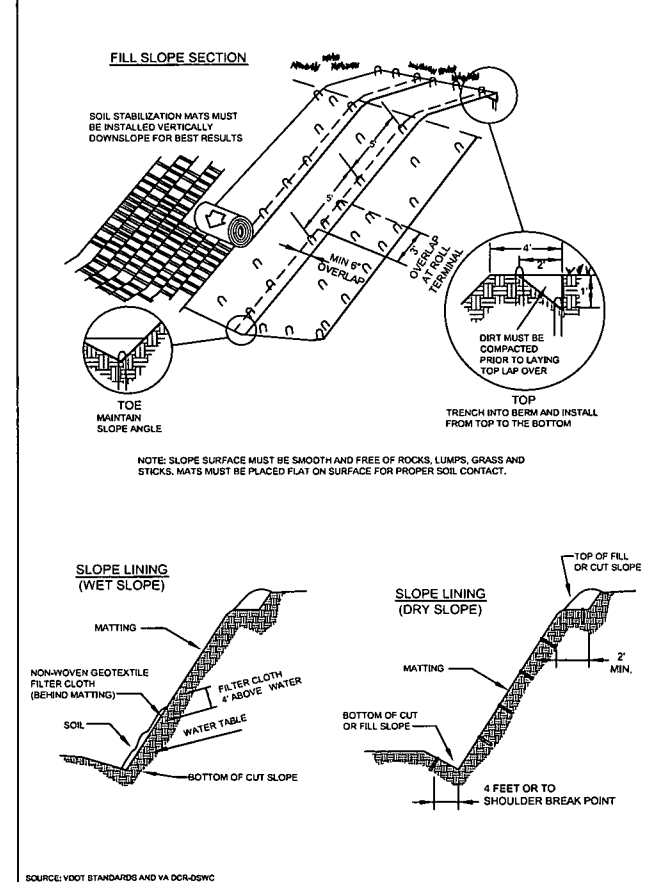
TYPICAL RECP CHANNEL INSTALLATION



SOURCE: VA DCR-DSWC AND NORTH AMERICAN GREEN

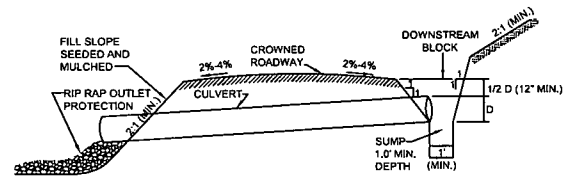
FIGURE 3.13.2

ROLLED EROSION CONTROL PRODUCTS

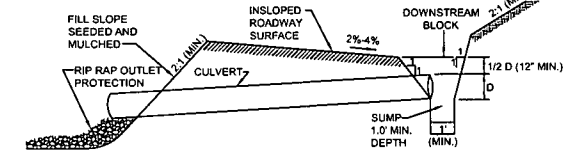


SOURCE: VDOT STANDARDS AND VA DCR-DSWC

CROWNED ROADWAY



INSLOPED ROADWAY

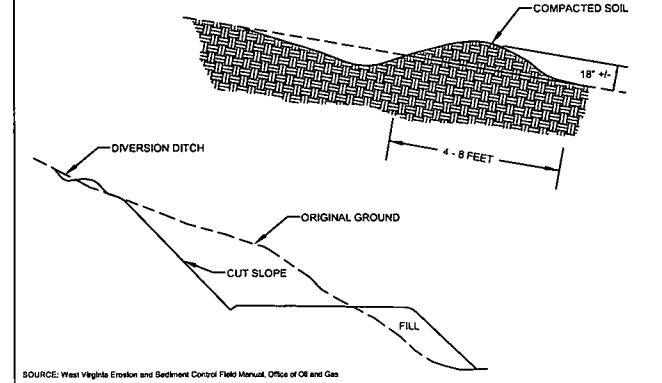


Cut and fill slopes shall be stabilized immediately upon completion of roadway grading. These areas shall be blanketed wherever they are located within 50 feet of a surface water or within 100 feet of a surface water where a suitable vegetative filter strip does not exist. A durable top dressing shall be provided for soils having low strength. Roadside ditches shall be provided with adequate protective lining. Adequately sized culverts or other suitable cross drains shall be provided at all slopes, springs, and drainageways. Roadway shall be inspected weekly and after each runoff event. Damaged roadways, ditches, or cross drains shall be repaired immediately.

SOURCE: VA DEPARTMENT OF ENVIRONMENTAL PROTECTION, BUREAU OF OIL AND GAS MANAGEMENT 8500-PA-000111 APPENDIX A BMP CONSTRUCTION DETAILS (REVISED)

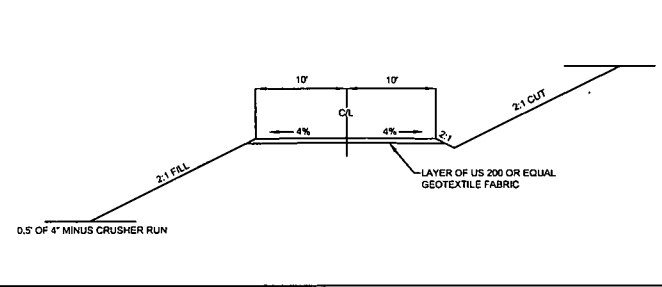
FIGURE II-3

DIVERSION DITCH - TEMPORARY



SOURCE: WEST VIRGINIA EROSION AND SEDIMENT CONTROL FIELD MANUAL, OFFICE OF OIL AND GAS

TYPICAL ROAD CROSS SECTION DETAIL



REVISION

DATE	UPDATE PER CLIENT REQUEST
04/03/2013	

ANTERO RESOURCES  
 THIS DOCUMENT WAS PREPARED FOR:  
 ANTERO RESOURCES  
 APPALACHIAN CORP

CONSTRUCTION DETAILS  
**PEARL JEAN NORTH**  
 CENTRALIZED FRESHWATER IMPOUNDMENT  
 GRANT DISTRICT  
 DODDRIDGE COUNTY, WEST VIRGINIA



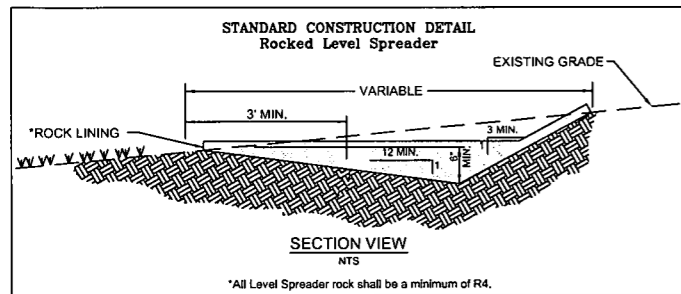
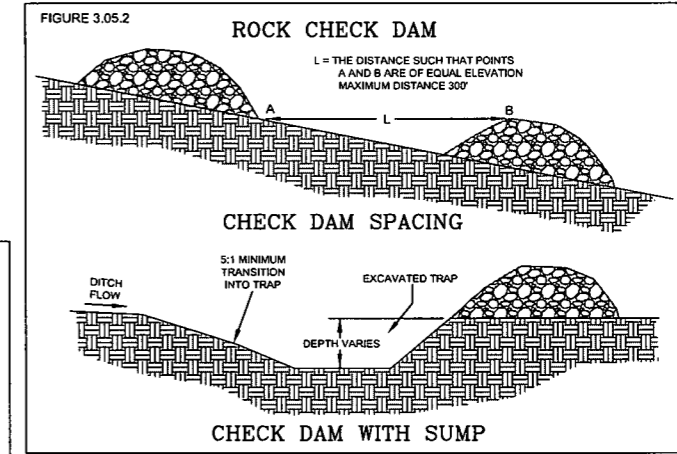
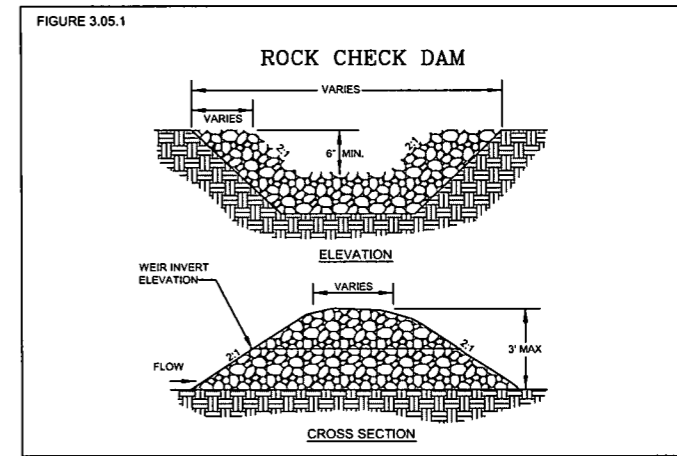
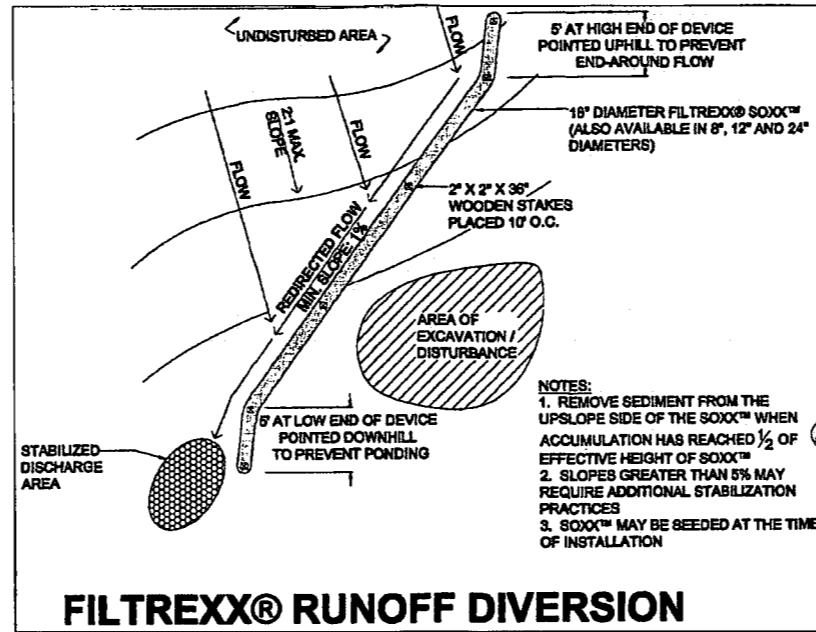
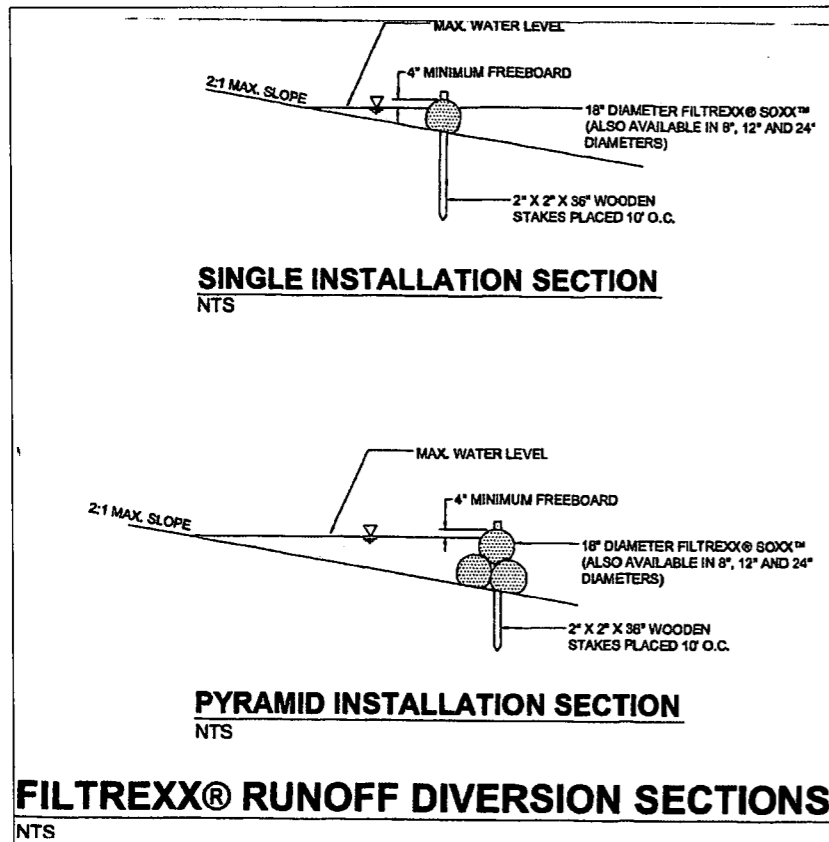


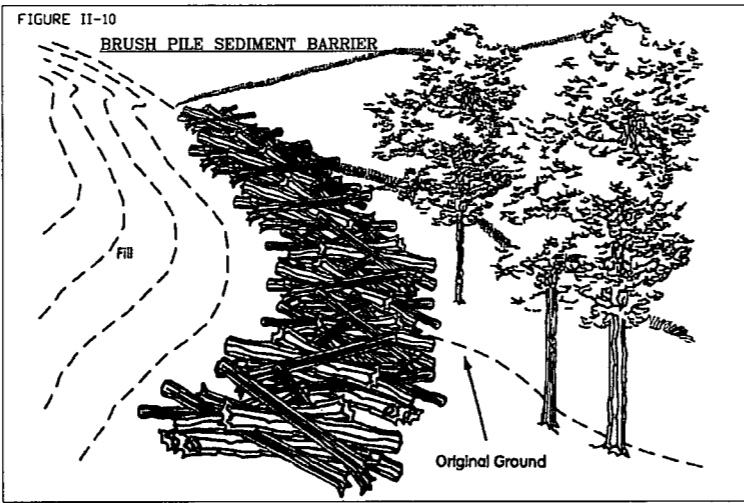
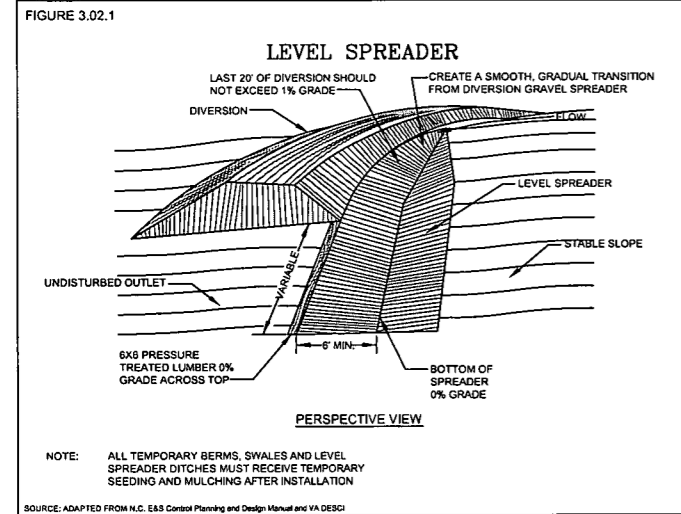
Table 4.1  
Compost Sock Fabric Minimum Specifications

Material Type	3 mil HDPE Photo-degradable	5 mil HDPE Photo-degradable	5 mil HDPE Bio-degradable	Multi-Filament Polypropylene (MPPP) Photo-degradable	Heavy Duty Multi-Filament Polypropylene (HDMPPP) Photo-degradable
Sock Diameters	12", 18"	12", 18", 24", 32"	12", 18", 24", 32"	12", 18", 24", 32"	12", 18", 24", 32"
Mesh Opening	3/8"	3/8"	3/8"	3/8"	1/8"
Tensile Strength		28 psi	28 psi	44 psi	202 psi
Ultraviolet Stability % Original Strength (ASTM G-155)	25% at 1000 hr.	25% at 1000 hr.		100% at 1000 hr.	100% at 1000 hr.
Minimum Functional Longevity	6 months	6 months	6 months	1 year	2 years

Two-ply systems

Inner Containment Netting	Outer Filtration Mesh
HDPE Marlex net Continuously wound Fusion-welded junctures 3/4" x 3/4" Max. aperture size	Composite Polypropylene Fabric (Woven layer & non-woven fleece mechanically fused via needle punch) 3/16" Max. aperture size

Sock fabrics composed of burlap may be used on projects lasting 6 months or less.



**STANDARD CONSTRUCTION DETAIL #4-1**  
Compost Filter Sock

SECTION VIEW  
NTS

PLAN VIEW  
NTS  
Adapted from Filtrex.

Sock fabric shall meet standards of Table 4.1. Compost shall meet the following standards:

Organic Matter Content	80% - 100% (dry weight basis)
Organic Portion	Fibrous and elongated
pH	5.5 - 8.0
Moisture Content	35% - 55%
Particle Size	98% pass through 1" screen
Soluble Salt Concentration	5.0 dS Maximum

Compost Filter Sock shall be placed at existing level grade. Both ends of the sock shall be extended at least 8 feet up the slope at 45 degrees to the main sock alignment (see Figure 4.1). Maximum slope above any sock shall not exceed that shown in Figure 4.2.

Traffic shall not be permitted to cross filter socks.

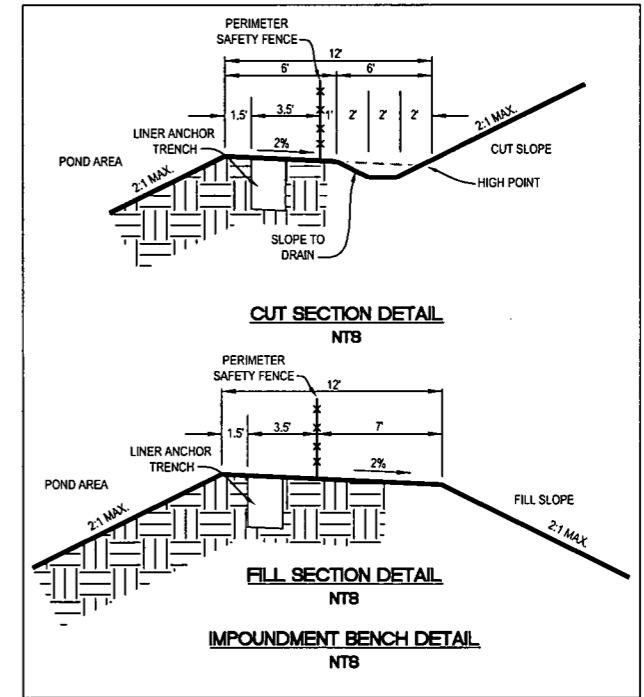
Accumulated Sediment shall be removed when it reaches 1/2 the above ground height of the sock and disposed in the manner described elsewhere in the plan.

Socks shall be inspected weekly and after each runoff event. Damaged socks shall be repaired according to manufacturer's specifications or replaced within 24 hours of inspection.

Biodegradable filter socks shall be replaced after 6 months; photodegradable socks after 1 year. Polypropylene socks shall be replaced according to manufacturer's recommendations.

Upon stabilization of the area tributary to the sock, stakes shall be removed. The sock may be left in place and vegetated or removed. In the latter case, the mesh shall be cut open and the mulch spread as a soil supplement.

In the event the ground is frozen, #5 rebar with safety caps shall be used instead of wooden stakes to anchor the filter sock. Once the ground thaws the rebar anchors shall be removed and replaced with 2" x 2" wooden stakes and installed as shown in the detail above.



**REVEGETATION**

Taken from the  
West Virginia Erosion and Sediment Control Field Manual  
West Virginia Division of Environmental Protection Office of Oil and Gas  
Charleston, W.Va.  
Section IV

**Temporary Seeding**

**a. General Conditions Where Practice Applies**

Where exposed soil surfaces are not to be fine-graded or worked for periods longer than 21 days. Temporary vegetative cover with sediment controls must be established where runoff will go directly into a stream. Immediately upon construction of the site (site includes road and location), vegetation must be established on road bank and location slopes. A permanent vegetative cover shall be applied to areas that will be left un-worked for a period of more than six months.

**b. Seed Mixtures and Planting Dates**

Refer to Tables 2 through 4 for recommended dates to establish vegetative cover and the approved lists of temporary and permanent plant species, and planting rates. Table 3 gives recommended types of temporary vegetation, rates of application, and optimum seeding dates. In situations where another cover is desired, contact the local soil conservation district for seeding recommendations.

**c. Seed Application**

Apply seed by broadcasting, drilling, or by hydroseed according to the rates indicates in Table IV-3. Perform all planting operations at right angles to the slope. Necessary site preparation and roughening of the soil surface should be done just prior to seeding. Seeded preparation may not be required on newly disturbed areas.

**Permanent Seeding**

**a. General**

Permanent vegetative cover will be established where no further soil disturbance is anticipated or needed. Soil fertility and pH level should be tested and adjusted according to seed species planted. Planting of permanent vegetative covers must be performed on all disturbed areas after completion of the drilling process. Any site that contains significant amounts of topsoil shall have the topsoil removed and stockpiled when feasible. Topsoil should not be added to slopes steeper than 2:1 unless a good bonding to the sub-layer can be achieved. After proper grading and seedbed preparation, the vegetation will reestablish ground cover for the control of surface water runoff erosion. All required seedbed preparation and loosening of soil by disking or dozer tracking should be performed just prior to seeding. If seedbed preparation is not feasible, 50% more seed shall be added to the recommended rates shown in Tables IV-3 and IV-4.

When hydroseeding, seedbed preparation may not be necessary if adequate site preparation was performed. Incorporate the appropriate amount of lime and/or fertilizer in the slurry mix when hydroseeding.

When hydroseeding, first mix the lime, fertilizer, and hydro-mulch in the recommended amount of water. Mix the seed and inoculants together within one hour prior to planting, and add to the slurry just before seeding. Apply the slurry uniformly over the prepared site. Assure that agitation is continuous throughout the seeding operation and the mix is applied within one hour of initial mixing.

**b. Lime and Fertilizer**

1. Lime shall be applied to all permanent seedings. The pH of the soil is to be determined and lime applied accordingly. Once the pH is known, select the amount of lime to be applied from Table IV-5.

2. Fertilizer shall be applied in all permanent seedings. Apply the equivalent for 500 lbs. minimum 10-20-20 fertilizer per acre or use the amount of fertilizer and lime recommended by a certified soil test.

3. Application: For best results and maximum benefits, the lime and fertilizer are to be applied at the time of seedbed preparation.

**c. Permanent Seed Mixtures**

Planners should take into consideration the species makeup of the existing pasture and the landowner's future pasture management plans when recommending seed mixtures. Selection: From Tables IV 4a and b, Permanent Seeding Mixtures Suitable for Establishment in West Virginia.

**Notes:**

- All legumes must be planted with the proper inoculants prior to seeding.
- Lathco Flatpea is potentially poisonous to some livestock.
- Only endophyte free varieties of Tall Fescue should be used. Tall Fescue and Crownvetch are also very invasive species, non-native to WV.
- For unprepared seedbeds or seeding outside the optimum timeframes, add 50% more seed to the specified rate. Mixtures in Table 4b are more wildlife and farm friendly; those listed in bold are suitable for use in shaded woodland settings. Mixtures in italic are suitable for use in filter strips.

**d. Seeding for Wildlife Habitat**

Consider the use of the native plants or locally adapted plants when selecting cover types and species for wildlife habitat. Wildlife friendly species or mixes that have multiple values should be considered. See wildlife friendly species/mixtures in Table IV-4b. Consider selecting no or low maintenance long-lived plants adaptable to sites which may be difficult to maintain with equipment.

**Mulching**

**a. General Organic Mulches**

The application of straw, hay or other suitable materials to the soil surface to prevent erosion. Straw made from wheat or oats is the preferred mulch, the use of hay is permissible, but not encouraged due to the risk of spreading invasive species. Mulch must be applied to all temporary and permanent seeding on all disturbed areas. Depending on site conditions, in critical areas such as waterways or steep slopes, additional or substitute soil protective measures may be used if deemed necessary. Examples include jute mesh and soil stabilization blankets or erosion control matting.

Areas that have been temporarily or permanently seeded should be mulched immediately following seeding. Mulches conserve desirable soil properties, reduce soil moisture loss, prevent crusting and sealing of the soil surface and provide a suitable microclimate for seed germination.

Areas that cannot be seeded because of the season should be mulched to provide some protection to the soil surface. An organic mulch, straw or hay should be used and the area then seeded as soon as weather or seasonal conditions permit. Do not use fiber mulch (cellulose-hydroseed) alone for this practice; at normal application rates it will not give the soil protection of other types of mulch. Wood cellulose fiber mulch is used in hydroseeding operations and applied as part of the slurry. It creates the best seed-soil contact when applied over the top of (as a separate operation) newly seeded areas. Fiber mulch does not alone provide sufficient protection on highly erodible soils, or during less than favorable growing conditions. Fiber mulch should not be used alone during the dry summer months or when used for late fall mulch cover. Use straw mulch during these periods and fiber mulch may be used to tack (anchor) the straw mulch. Fiber mulch is well suited for steep slopes, critical areas and areas susceptible to wind.

**b. Chemical Mulches, Soil Binders and Tackifiers**

A wide range of synthetic spray on materials are marketed to stabilize and protect the soil surface. These are mixed with water and sprayed over the mulch and to the soil. They may be used alone in some cases as temporary stabilizers, or in conjunction with fiber mulch, straw or hay. When used alone most chemical mulches do not have the capability to insulate the soil or retain soil moisture that organic mulches have.

**c. Specifications**

From Table IV-6 select the type of mulch and rate of application that will best suit the conditions at the site.

**d. Anchoring**

Depending on the field situation, mulch may not stay in place because of wind action or rapid water runoff. In such cases, mulch is to be anchored mechanically or with mulch netting.

**1. Mechanical Anchoring**

Apply mulch and pull mulch anchoring tool over the mulch. When a disk is used set the disk straight and pull across slope. Mulch material should be tucked into the soil about three inches.

**2. Mulch netting**

Follow manufacturer's recommendation when positioning and stapling the mulch netting in the soil.

**Table IV-1  
Recommended Seeding Dates**

Planting Dates	Suitability
March 1 - April 15 and August 1 - October 1	Best Seeding Periods
April 15 - August 1	HIGH RISK - moisture stress likely
October 1 - December 1	HIGH RISK - freeze damage to young seedlings
December 1 - March 1	Good seeding period. Dormant seeding

**Table 2  
Acceptable Fertilization Recommendation**

Species	N (lbs/ac)	P2O5 (lbs/ac)	Example Rec. (per acre)
Cool Season Grass	40	80	400 lbs. 10-20-20
CS Grass & Legume	30	60	300 lbs. 10-20-20
Temporary Cover	40	40	200 lbs. 19-19-19

**Table 3  
Temporary Cover**

Species	Seeding Rate (lbs/acre)	Optimum Seeding Dates	Drainage	pH Range
Annual Ryegrass	40	3/1 - 6/15 or 8/15 - 9/15	Well - Poorly	5.5 - 7.5
Field Bromegrass	40	3/1 - 6/15 or 8/15 - 9/15	Well - Mod. Well	6.0 - 7.0
Spring Oats	96	3/1 - 6/15	Well - Poorly	5.5 - 7.0
Sundangrass	40	5/15 - 8/15	Well - Poorly	5.5 - 7.5
Winter Rye	168	8/15 - 10/15	Well - Poorly	5.5 - 7.5
Winter Wheat	180	8/15 - 11/15	Well - Mod. Well	5.5 - 7.0
Japanese Millet	30	6/15 - 8/15	Well	4.5 - 7.0
Redtop	5	3/1 - 6/15	Well	4.0 - 7.5
Annual Ryegrass	26	3/1 - 6/15	Well - Poorly	5.5 - 7.5
Spring Oats	64	3/1 - 6/15	Well - Poorly	5.5 - 7.5

NOTE: These rates should be increased by 50% if planted April 15 - August 1 and October 1 - March 1.

**Table 4a  
Permanent Seeding Mixture**

Species/Mixture	Seeding Rate (lbs/acre)	Soil Drainage preference	pH Range
Crownvetch / Tall Fescue	10 - 15	Well - Mod. Well	5.0 - 7.5
Crownvetch / Perennial Ryegrass	10 - 15	Well - Mod. Well	5.0 - 7.5
Flatpea or Perennial Pea / Tall Fescue	20 / 15	Well - Mod. Well	4.0 - 8.0
Ladino Clover / Serecia Lespedeza / Tall Fescue	30 / 25 / 2	Well - Mod. Well	4.5 - 7.5
Tall Fescue / Ladino Clover / Redtop	40 / 3 / 3	Well - Mod. Well	5.0 - 7.5
Crownvetch / Tall Fescue / Redtop	10 / 20 / 3	Well - Mod. Well	5.0 - 7.5
Tall Fescue / Birdsfoot Trefoil / Redtop	40 / 10 / 3	Well - Mod. Well	5.0 - 7.5
Serecia Lespedeza / Tall Fescue / Redtop	25 / 30 / 3	Well - Mod. Well	4.5 - 7.5
Redtop / Tall Fescue / Creeping Red	30 / 3 / 50	Well - Mod. Well	5.0 - 7.5
Tall Fescue / Perennial Ryegrass / Tall Fescue / Lathco Flatpea *	50 / 10 / 15 / 20	Well - Poorly / Well - Poorly	4.5 - 7.5 / 5.8 - 8.0

\* Lathco Flatpea is potentially poisonous to some livestock. All legumes should be planted with proper inoculants prior to seeding. For unprepared seedbeds or seeding outside the optimum timeframe, add 50% more seed to the specified rate.

Mixtures listed in bold are suitable for use in shaded woodland settings; those in italics are suitable for use in filter strips.

**Table 4b  
Wildlife and Farm Friendly Seed Mixtures**

Species/Mixture	Seeding Rate (lbs/acre)	Soil Drainage preference	pH Range
KY Bluegrass / Redtop	20 / 3	Well - Mod. Well	5.5 - 7.5
Ladino Clover or Birdsfoot Trefoil	2 / 10		
Timothy / Alfalfa	5 / 12	Well - Mod. Well	6.5 - 8.0
Timothy / Birdsfoot Trefoil	5 / 8	Well - Poorly	5.5 - 7.5
Orchardgrass / Ladino Clover / Redtop	10 / 2 / 3	Well - Mod. Well	5.5 - 7.5
Orchardgrass / Ladino Clover	10 / 2	Well - Mod. Well	5.5 - 7.5
Orchardgrass / Perennial Ryegrass	20 / 10	Well - Mod. Well	5.5 - 7.5
Creeping Red Fescue / Perennial Ryegrass	30 / 10	Well - Mod. Well	5.5 - 7.5
Orchardgrass or KY Bluegrass	20	Well - Mod. Well	6.0 - 7.5
Birdsfoot Trefoil / Redtop / Orchardgrass	10 / 5 / 20	Well - Mod. Well	5.5 - 7.5
Lathco Flatpea * / Perennial Ryegrass	30 / 20	Well - Mod. Well	5.5 - 7.5
Lathco Flatpea * / Orchardgrass	30 / 20	Well - Mod. Well	5.5 - 7.5

\* Lathco Flatpea is potentially poisonous to some livestock. All legumes should be planted with proper inoculants prior to seeding. For unprepared seedbeds or seeding outside the optimum timeframe, add 50% more seed to the specified rate.

Mixtures listed in bold are suitable for use in shaded woodland settings; those in italics are suitable for use in filter strips.


**Table IV-5  
Lime and Fertilizer Application Table**

pH of Soil	Lime in Tons per Acre	Fertilizer, Lbs., per Acre (10-20-20 or Equivalent)
Above 6.0	2	500
5.0 to 6.0	3	500
Below 5.0	4	500

The pH can be determined with a portable pH testing kit or by sending the soil samples to a soil testing laboratory. When 4 tons of lime per acre are applied it must be incorporated into the soil by disking, backblading or tracking up and down the slope.

**Table IV-6  
Mulch Materials Rates and Uses**

Material	Minimum Rates per acre	Coverage	Remarks
Hay or Straw	2 to 3 Tons	Cover 75% to 90% of Surface	Subject to wind blowing or washing unless tied down
Wood Fiber	100 to 150 bales	Cover all	For hydroseeding
Pulp Fiber	1000 to 1500 lbs.	Disturbed Areas	
Wood - Cellulose			
Recirculated Paper			




**NAVITUS ENGINEERING INC.**  
151 Windy Hill Lane  
Winchester, Virginia 25662  
Telephone: (888) 662-4185  
www.navituseng.com

Engineering Survey Environmental GIS


REVISION UPDATE PER CLIENT REQUEST

DATE 04/03/2013



THIS DOCUMENT WAS PREPARED FOR ANTERO RESOURCES APPALACHIAN CORE

**PEARL JEAN NORTH**  
CENTRALIZED FRESHWATER IMPOUNDMENT  
GRANT DISTRICT  
DODDRIDGE COUNTY, WEST VIRGINIA



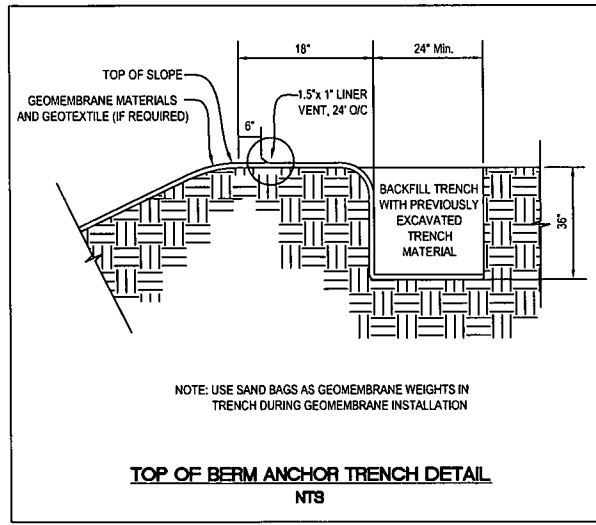
CONSTRUCTION DETAILS

DATE: 04/03/2013

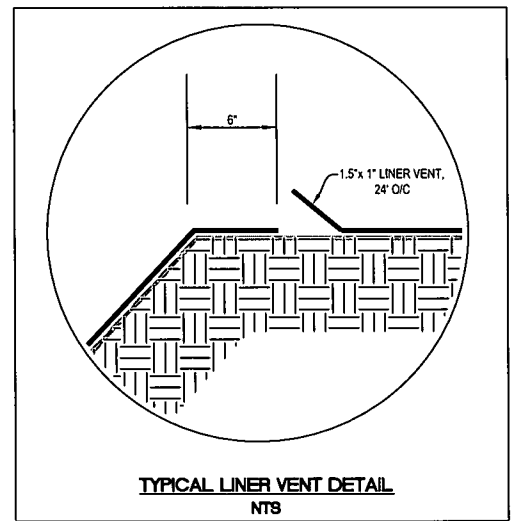
SCALE: N/A

SHEET 16 OF 20

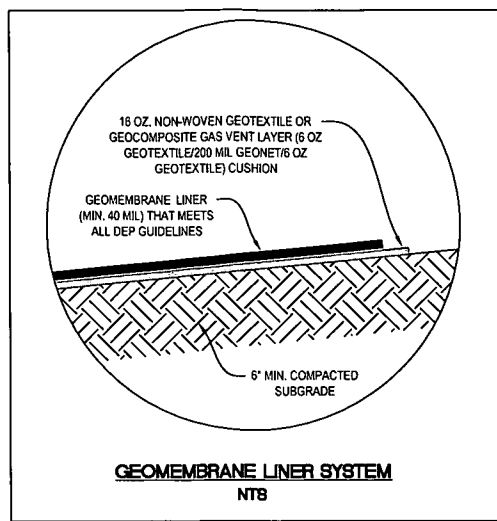




TOP OF BERM ANCHOR TRENCH DETAIL  
NTS

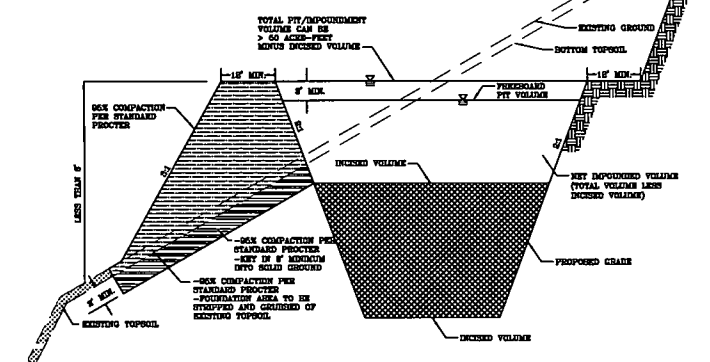


TYPICAL LINER VENT DETAIL  
NTS

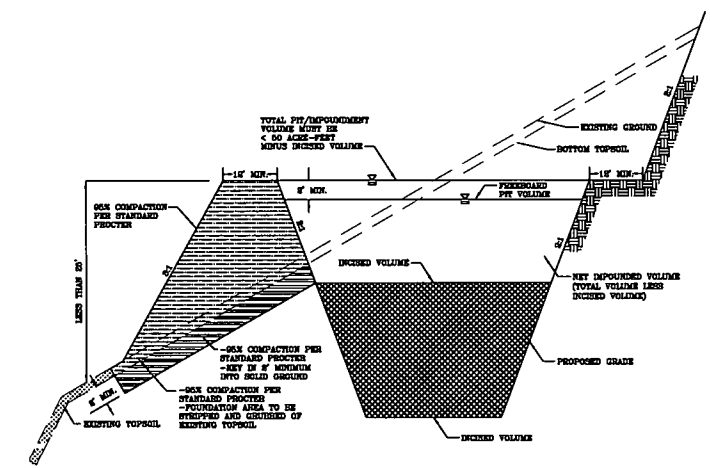


GEOMEMBRANE LINER SYSTEM  
NTS

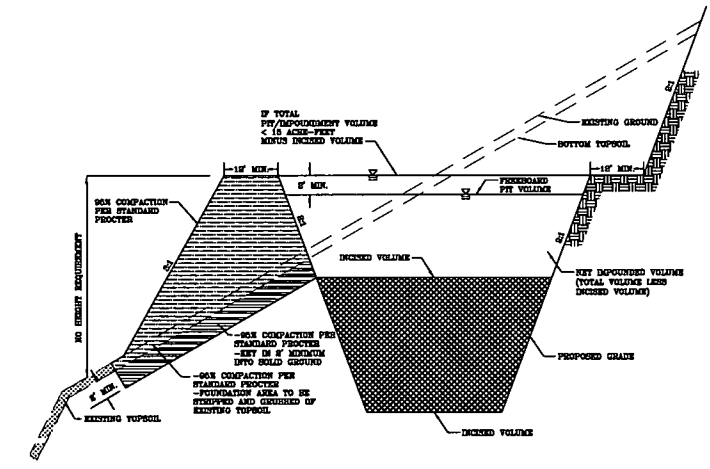
WEST VIRGINIA CODE 35 CSR 4  
DESIGN AND CONSTRUCTION REQUIREMENTS  
FOR ASSOCIATED PITS, ASSOCIATED IMPOUNDMENTS, &  
CENTRALIZED IMPOUNDMENTS  
GREATER THAN 5,000 BARRELS



SECTION VIEW



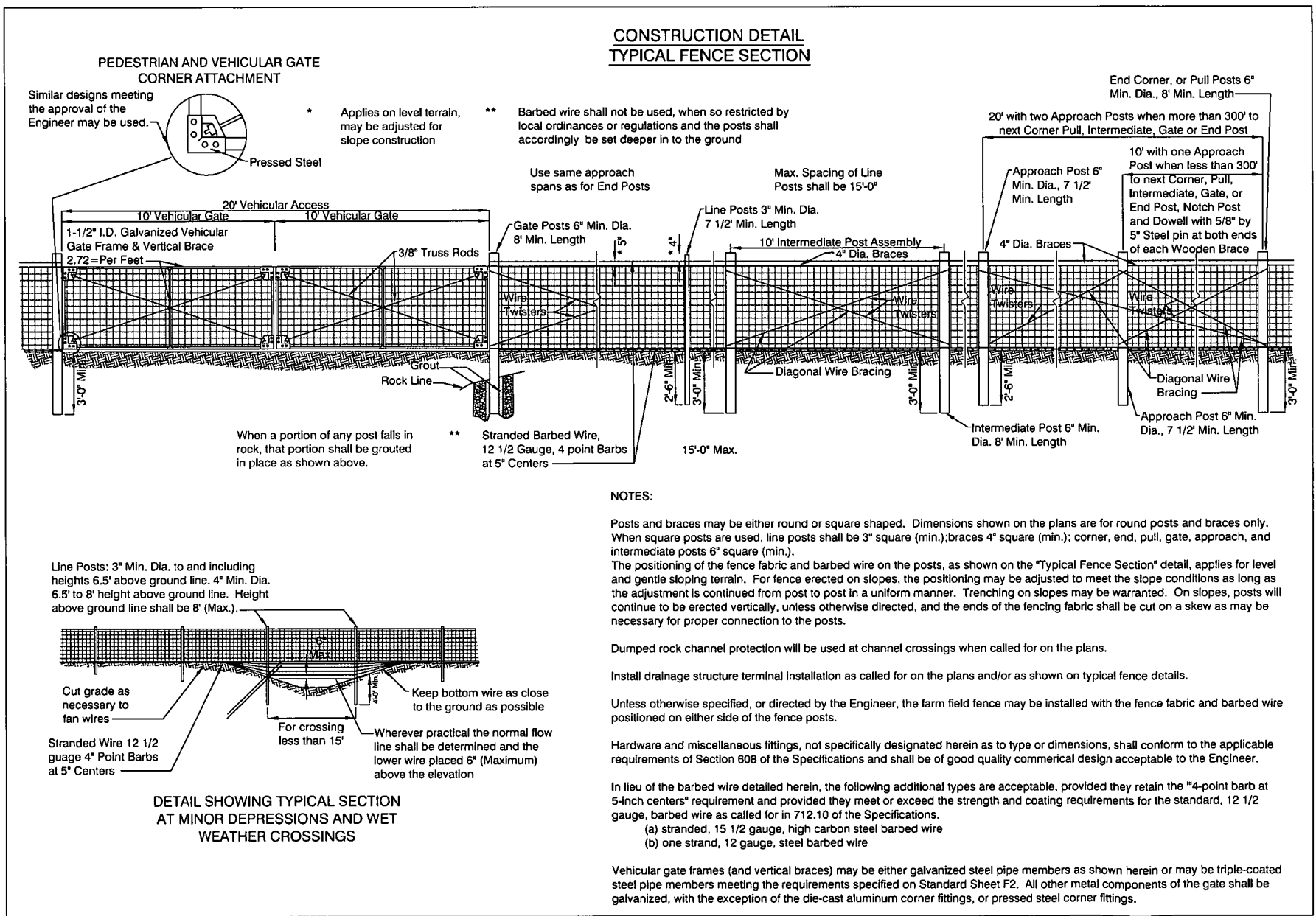
SECTION VIEW



SECTION VIEW

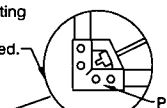
NOTES:  
1. ALL FILL SHOULD BE KEYED IN TO ORIGINAL GROUND EVERY 2-5 VERTICAL FEET DEPENDING ON EXISTING GROUND SLOPE  
2. MINIMUM OUTSIDE AND INSIDE EMBANKMENT (PILL) SLOPES SHALL BE 2H:1V. THE INSIDE AND OUTSIDE SLOPES MUST ADD UP TO 6H:1V.

NTS



CONSTRUCTION DETAIL  
TYPICAL FENCE SECTION

PEDESTRIAN AND VEHICULAR GATE  
CORNER ATTACHMENT



Similar designs meeting the approval of the Engineer may be used.

\* Applies on level terrain, may be adjusted for slope construction

\*\* Barbed wire shall not be used, when so restricted by local ordinances or regulations and the posts shall accordingly be set deeper in to the ground

Use same approach spans as for End Posts

Max. Spacing of Line Posts shall be 15'-0"

End Corner, or Pull Posts 6" Min. Dia., 8" Min. Length

20' with two Approach Posts when more than 300' to next Corner Pull, Intermediate, Gate or End Post

10' with one Approach Post when less than 300' to next Corner, Pull, Intermediate, Gate, or End Post, Notch Post and Dowell with 5/8" by 5" Steel pin at both ends of each Wooden Brace

Approach Post 6" Min. Dia., 7 1/2" Min. Length

10' Intermediate Post Assembly

4" Dia. Braces

Wire Twisters

Diagonal Wire Bracing

Intermediate Post 6" Min. Dia. 8" Min. Length

Approach Post 6" Min. Dia., 7 1/2" Min. Length

When a portion of any post falls in rock, that portion shall be grouted in place as shown above.

\*\* Stranded Barbed Wire, 12 1/2 Gauge, 4 point Barbs at 5" Centers

NOTES:

Posts and braces may be either round or square shaped. Dimensions shown on the plans are for round posts and braces only. When square posts are used, line posts shall be 3" square (min.); braces 4" square (min.); corner, end, pull, gate, approach, and intermediate posts 6" square (min.). The positioning of the fence fabric and barbed wire on the posts, as shown on the "Typical Fence Section" detail, applies for level and gentle sloping terrain. For fence erected on slopes, the positioning may be adjusted to meet the slope conditions as long as the adjustment is continued from post to post in a uniform manner. Trenching on slopes may be warranted. On slopes, posts will continue to be erected vertically, unless otherwise directed, and the ends of the fencing fabric shall be cut on a skew as may be necessary for proper connection to the posts.

Dumped rock channel protection will be used at channel crossings when called for on the plans.

Install drainage structure terminal installation as called for on the plans and/or as shown on typical fence details.

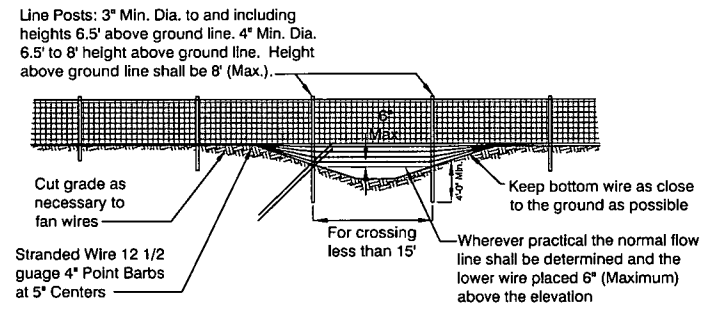
Unless otherwise specified, or directed by the Engineer, the farm field fence may be installed with the fence fabric and barbed wire positioned on either side of the fence posts.

Hardware and miscellaneous fittings, not specifically designated herein as to type or dimensions, shall conform to the applicable requirements of Section 608 of the Specifications and shall be of good quality commercial design acceptable to the Engineer.

In lieu of the barbed wire detailed herein, the following additional types are acceptable, provided they retain the "4-point barb at 5-inch centers" requirement and provided they meet or exceed the strength and coating requirements for the standard, 12 1/2 gauge, barbed wire as called for in 712.10 of the Specifications.

- (a) stranded, 15 1/2 gauge, high carbon steel barbed wire
- (b) one strand, 12 gauge, steel barbed wire

Vehicular gate frames (and vertical braces) may be either galvanized steel pipe members as shown herein or may be triple-coated steel pipe members meeting the requirements specified on Standard Sheet F2. All other metal components of the gate shall be galvanized, with the exception of the die-cast aluminum corner fittings, or pressed steel corner fittings.



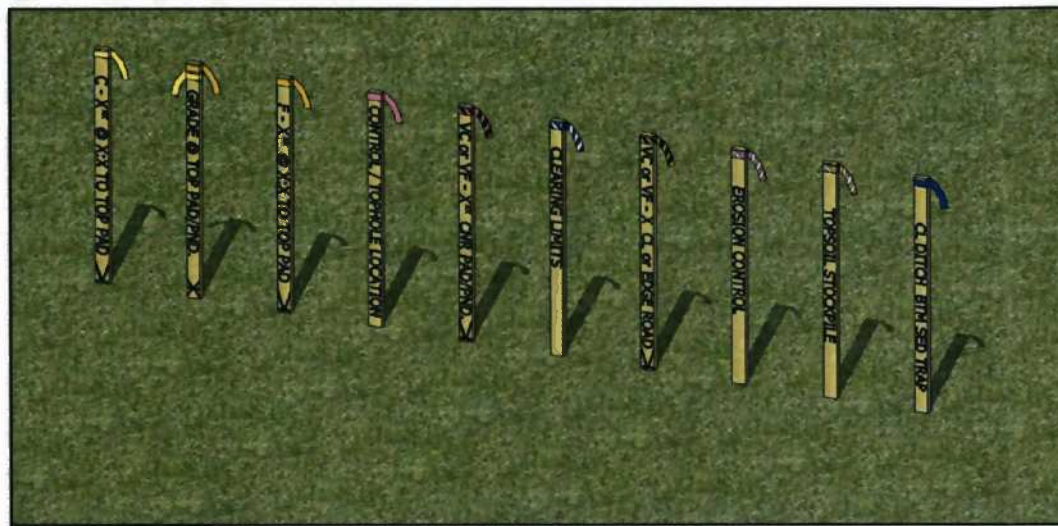
DETAIL SHOWING TYPICAL SECTION  
AT MINOR DEPRESSIONS AND WET  
WEATHER CROSSINGS

DATE	REVISION	UPDATE PER CLIENT REQUEST
04/03/2013		

**ANTERO RESOURCES**  
THIS DOCUMENT WAS PREPARED FOR:  
ANTERO RESOURCES  
APPALACHIAN CORP

CONSTRUCTION DETAILS  
**PEARL JEAN NORTH**  
CENTRALIZED FRESHWATER IMPOUNDMENT  
GRANT DISTRICT  
DODDRIDGE COUNTY, WEST VIRGINIA

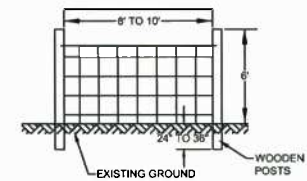




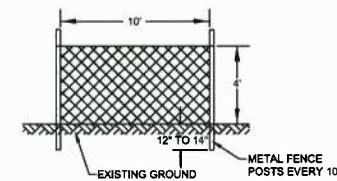
	<b>Yellow Ribbon:</b> Yellow Ribbon used to indicate top of Cuts (C) Cut to be determined at time of stakeout Slope determined by site design
	<b>Yellow &amp; Orange Ribbon:</b> Yellow and Orange Ribbon used to indicate Grade at Top of Pad/Pond/Pit
	<b>Orange Ribbon:</b> Orange Ribbon used to indicate toes of Fills (F) Fill to be determined at time of stakeout Slope determined by site design
	<b>Pink Ribbon:</b> Pink Ribbon used to indicate Top Hole Location Pink Ribbon used to indicate Survey Control Location
	<b>Pink &amp; Black Stripe Ribbon:</b> Pink & Black Stripe Ribbon used to indicate Vertical Cut (VC) at Pad/Pond/Pit corner or edge Pink & Black Stripe Ribbon used to indicate Vertical Fill (VF) at Pad/Pond/Pit corner or edge Vertical Cut/Vertical Fill to be determined at time of stakeout
	<b>Blue &amp; White Stripe Ribbon:</b> Blue & White Stripe Ribbon used to indicate clearing limits/construction limits
	<b>Orange &amp; Black Stripe Ribbon:</b> Orange & Black Stripe Ribbon used to indicate Vertical Cut (VC) at Centerline or edge of access road Orange & Black Stripe Ribbon used to indicate Vertical Fill (VF) at centerline or edge of access road
	<b>Pink &amp; White Stripe Ribbon:</b> Pink & White Stripe Ribbon used to indicate Erosion and Sediment Control Structures Silt Fence (SF) Reinforced Filter Fence (RFF) Super Silt Fence (SSF) Filter Sock (FS)
	<b>Orange &amp; White Stripe Ribbon:</b> Orange & White Stripe Ribbon used to indicate Topsoil Stockpile Locations
	<b>Blue Ribbon:</b> Blue Ribbon used to indicate Centerline (C) Ditch Blue Ribbon used to indicate Bottoms (BTM) Sediment Traps

ANTERO RESOURCES APPALACHIAN CORPORATION STANDARD RIBBON COLOR SCHEME  
PROVIDED BY ANTERO RESOURCES APPALACHIAN CORPORATION

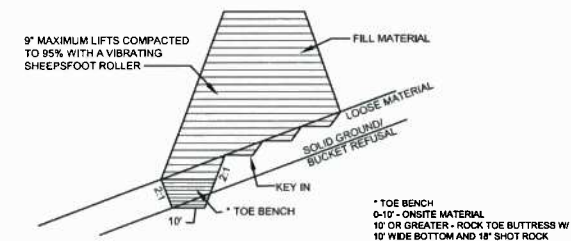
TYPICAL WOVEN WIRE FENCE DETAIL



TYPICAL CONSTRUCTION FENCE DETAIL



TOE BENCH DETAIL



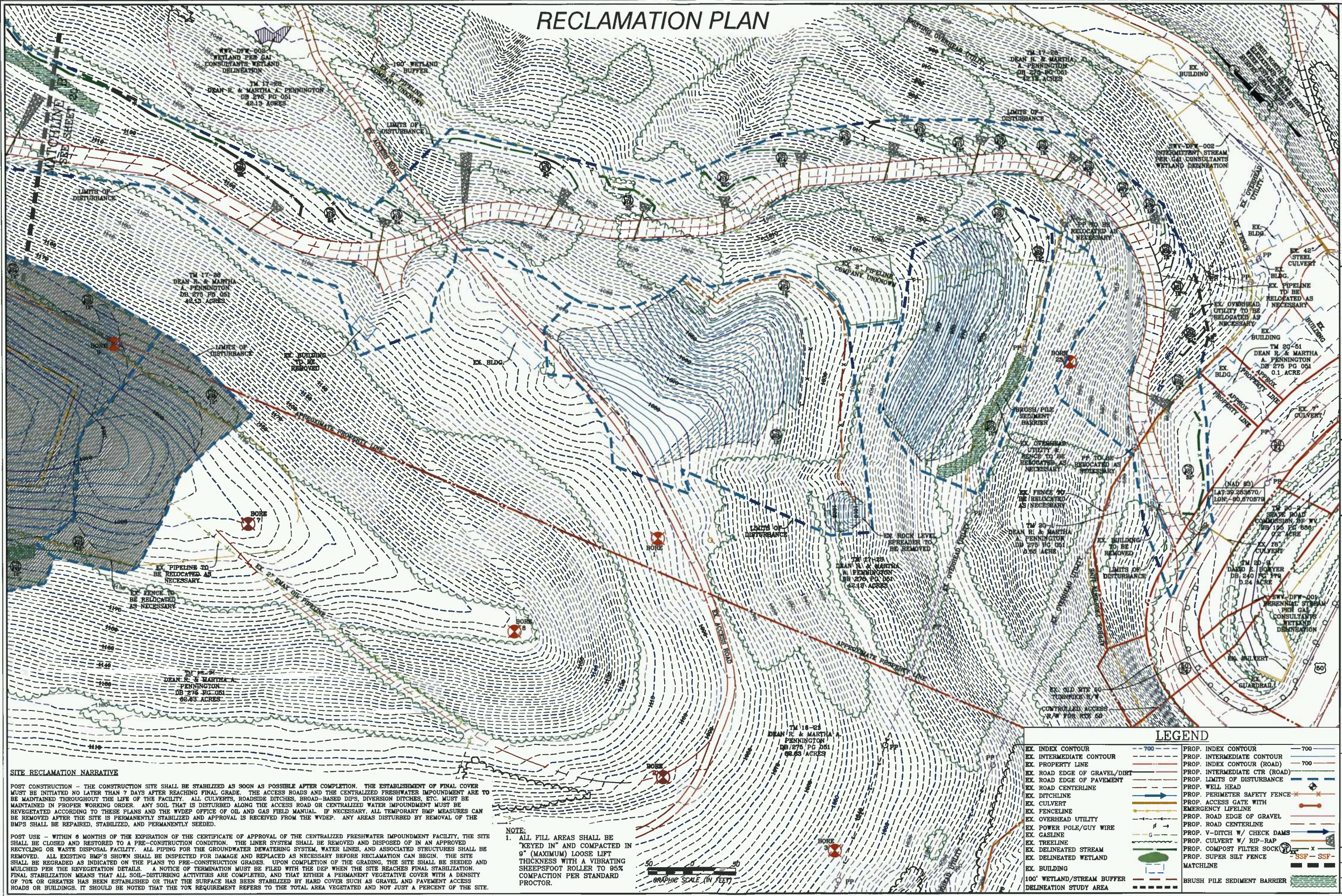
DATE	REVISION
04/03/2013	UPDATE PER CLIENT REQUEST

ANTERO RESOURCES  
THIS DOCUMENT  
WAS PREPARED  
FOR:  
ANTERO RESOURCES  
APPALACHIAN CORP

CONSTRUCTION DETAILS  
**PEARL JEAN NORTH**  
CENTRALIZED FRESHWATER IMPOUNDMENT  
GRANT DISTRICT  
DODDRIDGE COUNTY, WEST VIRGINIA



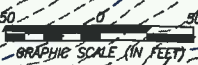
# RECLAMATION PLAN



POST CONSTRUCTION - THE CONSTRUCTION SITE SHALL BE STABILIZED AS SOON AS POSSIBLE AFTER COMPLETION. THE ESTABLISHMENT OF FINAL COVER MUST BE INITIATED NO LATER THAN 7 DAYS AFTER REACHING FINAL GRADE. THE ACCESS ROADS AND THE CENTRALIZED FRESHWATER IMPOUNDMENT ARE TO BE MAINTAINED THROUGHOUT THE LIFE OF THE FACILITY. ALL CULVERTS, ROADSIDE DITCHES, BROAD-BASED DIPS, DIVERSION DITCHES, ETC. MUST BE MAINTAINED IN PROPER WORKING ORDER. ANY SOIL THAT IS DISTURBED ALONG THE ACCESS ROAD OR CENTRALIZED WATER IMPOUNDMENT MUST BE REVEGETATED ACCORDING TO THESE PLANS AND THE WDEP OFFICE OF OIL AND GAS FIELD MANUAL. IF NECESSARY, ALL TEMPORARY BMP MEASURES CAN BE REMOVED AFTER THE SITE IS PERMANENTLY STABILIZED AND APPROVAL IS RECEIVED FROM THE WDEP. ANY AREAS DISTURBED BY REMOVAL OF THE BMP'S SHALL BE REPAIRED, STABILIZED, AND PERMANENTLY SEEDED.

POST USE - WITHIN 6 MONTHS OF THE EXPIRATION OF THE CERTIFICATE OF APPROVAL OF THE CENTRALIZED FRESHWATER IMPOUNDMENT FACILITY, THE SITE SHALL BE CLOSED AND RESTORED TO A PRE-CONSTRUCTION CONDITION. THE LINER SYSTEM SHALL BE REMOVED AND DISPOSED OF IN AN APPROVED RECYCLING OR WASTE DISPOSAL FACILITY. ALL PIPING FOR THE GROUNDWATER DEWATERING SYSTEM, WATER LINES, AND ASSOCIATED STRUCTURES SHALL BE REMOVED. ALL EXISTING BMP'S SHALL BE INSPECTED FOR DAMAGE AND REPLACED AS NECESSARY BEFORE RECLAMATION CAN BEGIN. THE SITE SHALL BE REGRADED AS INDICATED ON THE PLANS TO PRE-CONSTRUCTION GRADES. UPON COMPLETION OF THE GRADING, THE SITE SHALL BE SEEDING AND MULCHED PER THE REVEGETATION DETAILS. A NOTICE OF TERMINATION MUST BE FILED WITH THE DEP WHEN THE SITE REACHES FINAL STABILIZATION. FINAL STABILIZATION MEANS THAT ALL SOIL-DISTURBING ACTIVITIES ARE COMPLETED, AND THAT EITHER A PERMANENT VEGETATIVE COVER WITH A DENSITY OF 70% OR GREATER HAS BEEN ESTABLISHED OR THAT THE SURFACE HAS BEEN STABILIZED BY HARD COVER SUCH AS GRAVEL AND PAVEMENT ACCESS ROADS OR BUILDINGS. IT SHOULD BE NOTED THAT THE 70% REQUIREMENT REFERS TO THE TOTAL AREA VEGETATED AND NOT JUST A PERCENT OF THE SITE.

**NOTE:**  
 1. ALL FILL AREAS SHALL BE "KEYED IN" AND COMPACTED IN 9" (MAXIMUM) LOOSE LIFT THICKNESS WITH A VIBRATING SHEEPSFOOT ROLLER TO 95% COMPACTION PER STANDARD PROCTOR.



LEGEND	
EX. INDEX CONTOUR	--- 700 ---
EX. INTERMEDIATE CONTOUR	--- 700 ---
EX. PROPERTY LINE	---
EX. ROAD EDGE OF GRAVEL/DIRT	---
EX. ROAD EDGE OF PAVEMENT	---
EX. ROAD CENTERLINE	---
EX. DITCHLINE	---
EX. CULVERT	---
EX. FENCELINE	---
EX. OVERHEAD UTILITY	---
EX. POWER POLE/GUY WIRE	---
EX. GASLINE	---
EX. TREELINE	---
EX. DELINEATED STREAM	---
EX. DELINEATED WETLAND	---
EX. BUILDING	---
100' WETLAND/STREAM BUFFER DELINEATION STUDY AREA	---
PROP. INDEX CONTOUR	--- 700 ---
PROP. INTERMEDIATE CONTOUR	---
PROP. INDEX CONTOUR (ROAD)	---
PROP. INTERMEDIATE CTR (ROAD)	---
PROP. LIMITS OF DISTURBANCE	---
PROP. WELL HEAD	---
PROP. PERIMETER SAFETY FENCE	---
PROP. ACCESS GATE WITH EMERGENCY LEVERLINE	---
PROP. ROAD EDGE OF GRAVEL	---
PROP. ROAD CENTERLINE	---
PROP. V-DITCH W/ CHECK DAMS	---
PROP. CULVERT W/ RIP-RAP	---
PROP. COMPOST FILTER SOCK	---
PROP. SUPER SILT FENCE	---
MATCHLINE	---
BRUSH PILE SEDIMENT BARRIER	---

Engineering Survey Environmental GIS

151 Windy Hill Lane  
 Winchester, Virginia 22602  
 Telephone: (888) 662-4185  
 www.navituseng.com

DATE	REVISION
04/03/2013	UPDATE PER CLIENT REQUEST

ANTERO RESOURCES  
 THIS DOCUMENT WAS PREPARED FOR:  
 ANTERO RESOURCES  
 APPALACHIAN CORP.

RECLAMATION PLAN

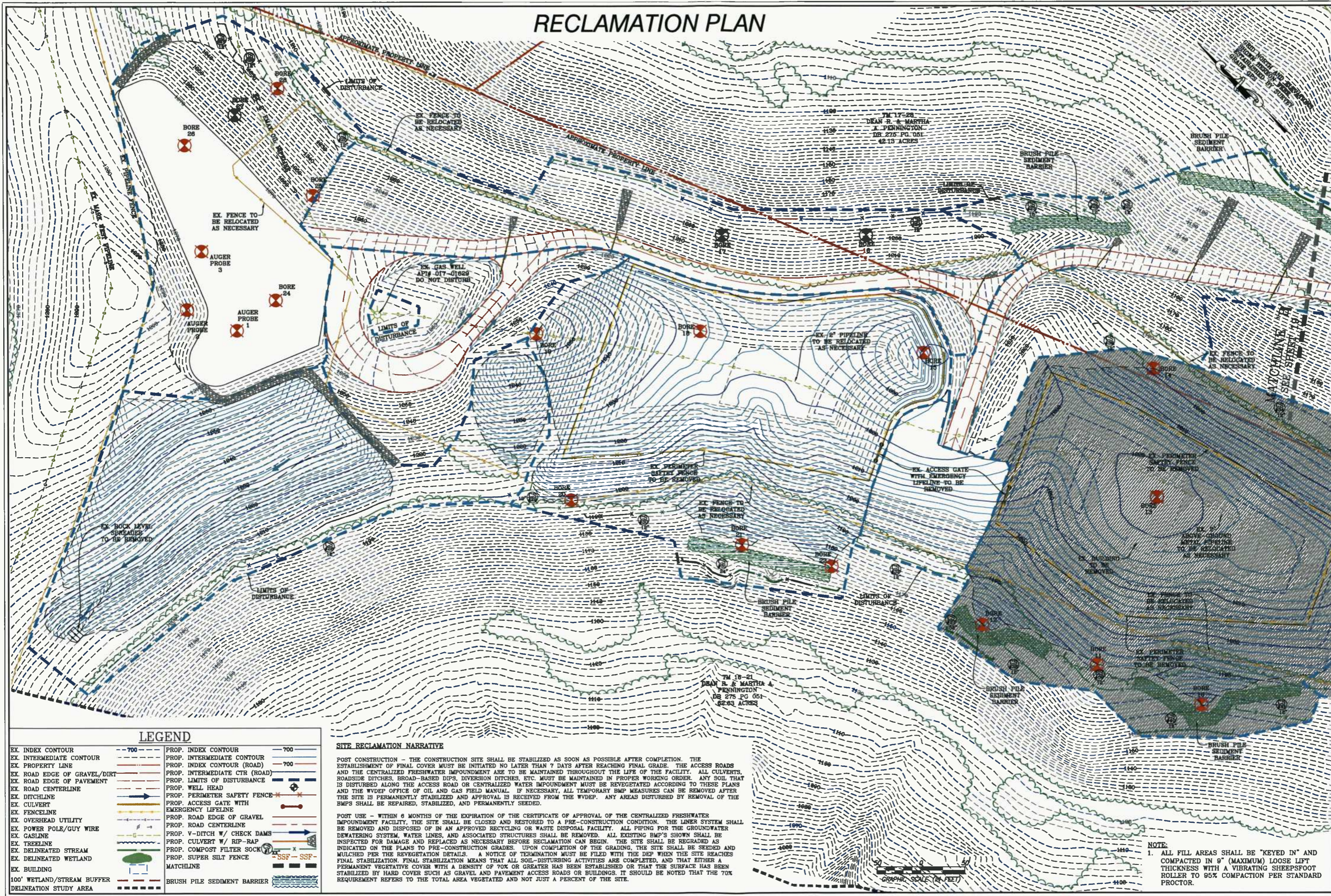
**PEARL JEAN NORTH**

**CENTRALIZED FRESHWATER IMPOUNDMENT**

GRANT DISTRICT  
 DODDRIDGE COUNTY, WEST VIRGINIA

DATE: 04/03/2013  
 SCALE: 1" = 50'  
 SHEET 19 OF 20

# RECLAMATION PLAN



## LEGEND

EX INDEX CONTOUR	--- 700 ---	PROP. INDEX CONTOUR	--- 700 ---
EX INTERMEDIATE CONTOUR	--- 700 ---	PROP. INTERMEDIATE CONTOUR	--- 700 ---
EX PROPERTY LINE	---	PROP. INDEX CONTOUR (ROAD)	--- 700 ---
EX ROAD EDGE OF GRAVEL/DIRT	---	PROP. INTERMEDIATE CTR (ROAD)	---
EX ROAD EDGE OF PAVEMENT	---	PROP. LIMITS OF DISTURBANCE	---
EX ROAD CENTERLINE	---	PROP. WELL HEAD	⊙
EX DITCHLINE	---	PROP. PERIMETER SAFETY FENCE	---
EX CULVERT	---	PROP. ACCESS GATE WITH EMERGENCY LIFELINE	---
EX FENCELINE	---	PROP. ROAD EDGE OF GRAVEL	---
EX OVERHEAD UTILITY	---	PROP. ROAD CENTERLINE	---
EX POWER POLE/GUY WIRE	---	PROP. V-DITCH W/ CHECK DAMS	---
EX GASLINE	---	PROP. CULVERT W/ RIP-RAP	---
EX TREELINE	---	PROP. COMPOST FILTER SOCK	---
EX DELINEATED STREAM	---	PROP. SUPER SILT FENCE	SSSF - SSSF
EX DELINEATED WETLAND	---	MATCHLINE	---
EX BUILDING	---	BRUSH PILE SEDIMENT BARRIER	---
100' WETLAND/STREAM BUFFER DELINEATION STUDY AREA	---		

## SITE RECLAMATION NARRATIVE

**POST CONSTRUCTION** - THE CONSTRUCTION SITE SHALL BE STABILIZED AS SOON AS POSSIBLE AFTER COMPLETION. THE ESTABLISHMENT OF FINAL COVER MUST BE INITIATED NO LATER THAN 7 DAYS AFTER REACHING FINAL GRADE. THE ACCESS ROADS AND THE CENTRALIZED FRESHWATER IMPOUNDMENT ARE TO BE MAINTAINED THROUGHOUT THE LIFE OF THE FACILITY. ALL CULVERTS, ROADSIDE DITCHES, BROAD-BASED DIPS, DIVERSION DITCHES, ETC. MUST BE MAINTAINED IN PROPER WORKING ORDER. ANY SOIL THAT IS DISTURBED ALONG THE ACCESS ROAD OR CENTRALIZED WATER IMPOUNDMENT MUST BE REVEGETATED ACCORDING TO THESE PLANS AND THE WVDEP OFFICE OF OIL AND GAS FIELD MANUAL. IF NECESSARY, ALL TEMPORARY BMP MEASURES CAN BE REMOVED AFTER THE SITE IS PERMANENTLY STABILIZED AND APPROVAL IS RECEIVED FROM THE WVDEP. ANY AREAS DISTURBED BY REMOVAL OF THE BMP'S SHALL BE REPAIRED, STABILIZED, AND PERMANENTLY SEEDDED.

**POST USE** - WITHIN 6 MONTHS OF THE EXPIRATION OF THE CERTIFICATE OF APPROVAL OF THE CENTRALIZED FRESHWATER IMPOUNDMENT FACILITY, THE SITE SHALL BE CLOSED AND RESTORED TO A PRE-CONSTRUCTION CONDITION. THE LINER SYSTEM SHALL BE REMOVED AND DISPOSED OF IN AN APPROVED RECYCLING OR WASTE DISPOSAL FACILITY. ALL PIPING FOR THE GROUNDWATER DEWATERING SYSTEM, WATER LINES, AND ASSOCIATED STRUCTURES SHALL BE REMOVED. ALL EXISTING BMP'S SHOWN SHALL BE INSPECTED FOR DAMAGE AND REPLACED AS NECESSARY BEFORE RECLAMATION CAN BEGIN. THE SITE SHALL BE REGRADED AS INDICATED ON THE PLANS TO PRE-CONSTRUCTION GRADES. UPON COMPLETION OF THE GRADING, THE SITE SHALL BE SEEDED AND MULCHED PER THE REVEGETATION DETAILS. A NOTICE OF TERMINATION MUST BE FILED WITH THE DEP WHEN THE SITE REACHES FINAL STABILIZATION. FINAL STABILIZATION MEANS THAT ALL SOIL-DISTURBING ACTIVITIES ARE COMPLETED, AND THAT EITHER A PERMANENT VEGETATIVE COVER WITH A DENSITY OF 70% OR GREATER HAS BEEN ESTABLISHED OR THAT THE SURFACE HAS BEEN STABILIZED BY HARD COVER SUCH AS GRAVEL AND PAVEMENT ACCESS ROADS OR BUILDINGS. IT SHOULD BE NOTED THAT THE 70% REQUIREMENT REFERS TO THE TOTAL AREA VEGETATED AND NOT JUST A PERCENT OF THE SITE.

## NOTE:

1. ALL FILL AREAS SHALL BE "KEYED IN" AND COMPACTED IN 9" (MAXIMUM) LOOSE LIFT THICKNESS WITH A VIBRATING SHEEPSFOOT ROLLER TO 95% COMPACTION PER STANDARD PROCTOR.

Engineering Survey Environmental GIS

**NAVITUS ENGINEERING INC.**

151 Wanda Hill Lane  
Winchester, Virginia 22602  
Telephone: (888) 662-4185  
www.navituseg.com

DATE	REVISION	UPDATE PER CLIENT REQUEST
04/03/2013		

**ANTERO RESOURCES**

THIS DOCUMENT WAS PREPARED FOR:

ANTERO RESOURCES  
APPALACHIAN CORP

RECLAMATION PLAN

**PEARL JEAN NORTH**

CENTRALIZED FRESHWATER IMPOUNDMENT

GRANT DISTRICT

DODDRIDGE COUNTY, WEST VIRGINIA



DATE: 04/03/2013

SCALE: 1" = 50'

SHEET 20 OF 20