

Doddridge County Sheriff
Flood Plain Ordinance Fund

1010
69-217/515

DATE July 2, 2013

PAY TO THE ORDER OF ANTERO RESOURCES

\$ 2,369.32

Two Thousand Three Hundred Sixty-nine Dollars and 32/100



DOLLARS  Security features included. Details on back.
Beth W. Rogers
MP

MEMO #13-015 Hinter Heirs North Reimbursement

⑈001010⑈ ⑆051502175⑆

1196499⑈



ANTERO RESOURCES APPALACHIAN
 1625 17th STREET, SUITE 300
 DENVER, COLORADO 80202

Vendor Name	Vendor No.	Date	Check Number	Check Total
DODDRIDGE COUNTY COMMISSION	43312	Jun-18-2013	31800	\$2,441.39

VOUCHER	VENDOR INV #	INV DATE	TOTAL AMOUNT	PRIOR PMTS & DISCOUNTS	NET AMOUNT
06-AP-8197	ERHEIRSNORTH	06/18/13	2,441.39	0.00	2,441.39
FLOOD PLAIN PERMIT - HINTER HEIRS NORTH					
TOTAL INVOICES PAID					2,441.39

By: BH - MEH - AML
 Asst. Chief Tax Deputy

Michael Headley
 Sheriff of Doddridge County

The Person paying Money into the Treasury shall forthwith file one of these Receipts with the County Clerk

Doddridge County, West Virginia

No. 4772

Date: June 25, 2013
 Customer copy

Received: #13-015 Antero Resources \$2,441.39

In Payment For: 318 Building Permits (LP)

For: 12-Flood Plain Ordinanc Fund #20 Fund

By: BH - MEH - AML
 Asst. Chief Tax Deputy

Michael Headley
 Sheriff of Doddridge County

Doddridge County Flood Plain Refund Calculator (if not in Flood Plain)**Hinter Heirs North**

Estimated Construction Costs	188,277.00
Amount over \$100,000	88,277.00
Drilling Oil and Gas Well Fee	1,000.00
Deposit for additional charges	1,000.00
\$5 per \$1,000 over \$100,000	441.39
Amount Due with application	2,441.39
95% of Application Fee minus \$1,000 deposit	1,369.32
Cost for Permit	72.07
Total Refund (Includes 100% of 1,000 deposit)	\$2,369.32



June 21, 2013

Antero Resources
1625 17th Street
Denver, Colorado 80202
Office 303.357.7310
Fax 303.357.7315

Doddridge County Commission
Attn: Dan Wellings, Doddridge County Floodplain Manager
118 East Court Street, Room 102
West Union, WV 26456

Mr. Wellings:

Antero Resources Appalachian Corporation (Antero) would like to submit a Doddridge County Floodplain permit application for our Hinter North Centralized Impoundment. Our project is located in Doddridge County, New Milton District and per FIRM map #54017C250C, this location is not within the floodplain.

Attached you will find the following:

- Doddridge County Floodplain Permit Application
- FIRM Map
- A detailed set of plans signed by a WV licensed professional engineer
- Copies of other required permits
- Maintenance, Monitoring and Emergency Action Plan

If you have any questions please feel free to contact me at (303) 357-6820.

Thank you in advance for your consideration.

Sincerely,

Shauna Redican
Permit Representative
Antero Resources Appalachian Corporation

Enclosures

2013 JUN 25 PM 2:34
FIRM
DODDRIDGE COUNTY, WV

DODDRIDGE COUNTY FLOODPLAIN DEVELOPMENT PERMIT APPLICATION

SECTION 1: GENERAL PROVISIONS (APPLICANT TO READ AND SIGN)

1. No work may start until a permit is issued.
2. The permit may be revoked if any false statements are made herein.
3. If revoked, all work must cease until permit is re-issued.
4. Development shall not be used or occupied until a Certificate of Compliance is issued.
5. The permit will expire if no work is commenced within six months of issuance.
6. Applicant is hereby informed that other permits may be required to fulfill local, state, and federal requirements.
7. Applicant hereby gives consent to the Floodplain Administrator/Manager or his/her representative to make inspections to verify compliance.
8. **I, THE APPLICANT CERTIFY THAT ALL STATEMENTS HEREIN AND IN ATTACHMENTS TO THIS APPLICATION ARE, TO THE BEST OF MY KNOWLEDGE, TRUE AND ACCURATE.**

APPLICANT'S SIGNATURE 

DATE June 21, 2013

SECTION 2: PROPOSE DEVELOPMENT (TO BE COMPLETED BY APPLICANT).

IF THE APPLICANT IS NOT A NATURAL PERSON, THE NAME, ADDRESS, AND TELEPHONE NUMBER OF A NATURAL PERSON WHO SHALL BE APPOINTED BY THE APPLICANT TO RECEIVE NOTICE PURSUANT TO ANY PROVISION OF THE CURRENT DODDRIDGE COUNTY FLOODPLAIN ORDINANCE.

Antero Resources Appalachian Corporation - Gerard G. Alberts,
Environmental & Regulatory Manager

APPLICANT'S NAME: _____

ADDRESS: 1625 17th Street, Denver, CO 80202

TELEPHONE NUMBER: Contact Shauna Redican: 303-357-6820

BUILDER'S NAME: Antero Resources Appalachian Corporation
ADDRESS: 1625 17th Street, Denver, CO 80202
TELEPHONE NUMBER: (303) 357-7310

ENGINEER'S NAME: Navitus Engineering, Inc. - Cyrus S. Kump
ADDRESS: 151 Windv Hill Lane
TELEPHONE NUMBER: 888-662-4185

PROJECT LOCATION:

NAME OF SURFACE OWNER/OWNERS (IF NOT THE APPLICANT) Please see attached Exhibit A

ADDRESS OF SURFACE OWNER/OWNERS (IF NOT THE APPLICANT) Please see attached Exhibit A

DISTRICT: New Milton

DATE/FROM WHOM PROPERTY

PURCHASED: N/A

LAND BOOK DESCRIPTION:

DEED BOOK REFERENCE: Please see attached Exhibit A

TAX MAP REFERENCE: Please see attached Exhibit A

EXISTING BUILDINGS/USES OF PROPERTY: None

NAME OF AT LEAST ONE ADULT RESIDING IN EACH RESIDENCE LOCATED UPON THE SUBJECT PROPERTY Please see attached Exhibit A

ADDRESS OF AT LEAST ONE ADULT RESIDING IN EACH RESIDENCE LOCATED UPON THE SUBJECT PROPERTY Please see attached Exhibit A

To avoid delay in processing the application, please provide enough information to easily identify the project location.

DESCRIPTION OF WORK (CHECK ALL APPLICABLE BOXES)

A. STRUCTURAL DEVELOPMENT

ACTIVITY

STRUCTURAL TYPE

- | | | | |
|--------------------------|-------------------------|--------------------------|----------------------------------|
| <input type="checkbox"/> | New Structure | <input type="checkbox"/> | Residential (1 – 4 Family) |
| <input type="checkbox"/> | Addition | <input type="checkbox"/> | Residential (more than 4 Family) |
| <input type="checkbox"/> | Alteration | <input type="checkbox"/> | Non-residential (floodproofing) |
| <input type="checkbox"/> | Relocation | <input type="checkbox"/> | Combined Use (res. & com.) |
| <input type="checkbox"/> | Demolition | <input type="checkbox"/> | Replacement |
| <input type="checkbox"/> | Manufactured/Mobil Home | | |

B. OTHER DEVELOPMENT ACTIVITIES:

- Fill Mining Drilling Pipelining
 Grading
 Excavation (except for STRUCTURAL DEVELOPMENT checked above)
 Watercourse Altercation (including dredging and channel modification)
 Drainage Improvements (including culvert work)
 Road, Street, or Bridge Construction *Access Road Construction as shown on attached design
 Subdivision (including new expansion)
 Individual Water or Sewer System
 Other (please specify)
-

C. STANDARD SITE PLAN OR SKETCH

1. SUBMIT ALL STANDARD SITE PLANS, IF ANY HAVE BEEN PREPARED.
2. IF STANDARD SITE PLANS HAVE NOT BEEN PREPARED:
 SKETCH ON A SEPARATE 8 ½ X 11 INCH SHEET OF PAPER THE SHAPE AND LOCATION OF THE LOT. SHOW THE LOCATION OF THE INTENDED CONSTRUCTION OR LAND USE INDICATING BUILDING SETBACKS, SIZE & HEIGHT. IDENTIFY EXISTING BUILDINGS, STRUCTURES OR LAND USES ON THE PROPERTY.
3. SIGN AND DATE THE SKETCH.

ACTUAL TOTAL CONSTRUCTION COSTS OF THE COMPLETE DEVELOPMENT IRRESPECTIVE OF WHETHER ALL OR ANY PART OF THE SUBJECT PROPOSED CONSTRUCTION PROJECT IS WITHIN THE FLOODPLAIN \$ 188,277.00

*See attached Floodplain Calculation Fee

D. ADJACENT AND/OR AFFECTED LANDOWNER

1. NAME AND ADDRESS OF ALL OWNERS OF SURFACE TRACTS ADJACENT TO THE AREA OF THE SURFACE TRACT (UP & DOWN STREAM) UPON WHICH THE PROPOSED ACTIVITY WILL OCCUR AND ALL OTHER SURFACE OWNERS UP & DOWN STREAM) WHO OWN PROPERTY THAT MAY BE AFFECTED BY FLOODING AS IS DEMONSTRATED BY A FLOODPLAIN STUDY OR SURVEY (IF ONE HAS BEEN COMPLETED).

NAME: N/A
 ADDRESS: _____

NAME: _____
 ADDRESS: _____

NAME: _____
 ADDRESS: _____

NAME: _____
 ADDRESS: _____

1. NAME AND ADDRESS OF AT LEAST ONE ADULT RESIDING IN EACH RESIDENCE LOCATED UPON ANY ADJACENT PROPERTY AT THE TIME THE FLOODPLAIN PERMIT APPLICATION IS FILED AND THE NAME AND ADDRESS OF AT LEAST ONE ADULT RESIDING IN ANY HOME ON ANY PROPERTY THAT MAY BE AFFECTED BY FLOODING AS IS DEMONSTRATED BY A FLOODPLAIN STUDY OR SURVEY.

NAME: N/A
 ADDRESS: _____

NAME: _____
 ADDRESS: _____

NAME: _____
 ADDRESS: _____

NAME: _____
 ADDRESS: _____

E. CONFIRMATION FORM

THE APPLICANT ACKNOWLEDGES, AGREES, AND CONFIRMS THAT HE/IT WILL PAY WITHIN 30 DAYS OF RECEIPT OF INVOICE BY THE COUNTY FOR ALL EXPENSES RELATIVE TO THE PERMIT APPLICATION PROCESS GREATER THAN THE REQUIRED DEPOSIT FOR EXPENSES INCLUDING:

- (A) PERSONAL SERVICE OF PROCESS BY THE DODDRIDGE COUNTY SHERIFF AT THE RATES PERMITTED BY LAW FOR SUCH SERVICE.
- (B) SERVICE BY CERTIFIED MAIL RETURN RECEIPT REQUESTED.
- (C) PUBLICATION.

Hinter Heirs North Doddridge County Floodplain Permit – Exhibit A

Surface Owner Name	Address	Deed/Page	Tax Map/ Parcel
David Burton and Vivian Burton	1094 Williamstown Pike, Williamstown, WV 26187	29/444	15/12
Richard and Lreta Delaney	903 56th Street, Vienna, WV 26105	29/444	15/12

- (D) COURT REPORTING SERVICES AT ANY HEARINGS REQUESTED BY THE APPLICANT.
- (E) CONSULTANTS AND/OR HEARING EXPERTS UTILIZED BY DODDRIDGE COUNTY FLOODPLAIN ADMINISTRATOR/MANAGER OR FLOODPLAIN APPEALS BOARD FOR REVIEW OF MATERIALS AND/OR TESTIMONY REGARDING THE EFFICACY OF GRANTING OR DENYING THE APPLICANT'S FLOODPLAIN PERMIT.

NAME (PRINT): Anthony Smith
 SIGNATURE: Am N M DATE: 6/24/13

After completing SECTION 2, APPLICANT should submit form to Floodplain Administrator/Manager or his/her representative for review.

SECTION 3: FLOODPLAIN DETERMINATION (to be completed by Floodplain Administrator/Manager or his/her representative)

THE PROPOSED DEVELOPMENT:

THE PROPOSED DEVELOPMENT IS LOCATED ON:

FIRM Panel: 250
 Dated: 10/04/2011

Is **NOT** located in a Specific Flood Hazard Area (Notify applicant that the application review is complete and **NO FLOODPLAIN DEVELOPMENT PERMIT IS REQUIRED**).

Is located in Special Flood Hazard Area.
 FIRM zone designation _____
 100-Year flood elevation is: _____ NGVD (MSL)

Unavailable

The proposed development is located in a floodway.
 FBFM Panel No. _____ Dated _____

See section 4 for additional instructions.

SIGNED *Dan Wellins*

DATE 06/25/2013

SECTION 4: ADDITIONAL INFORMATION REQUIRED (To be completed by Floodplain Administrator/Manager or his/her representative)

The applicant must submit the documents checked below before the application can be processed.

- A plan showing the location of all existing structures, water bodies, adjacent roads, lot dimensions and proposed development.
- Development plans, drawn to scale, and specifications, including where applicable: details for anchoring structures, storage tanks, proposed elevation of lowest floor, (including basement or crawl space), types of water resistant materials used below the first floor, details of flood proffing of utilities located below the first floor and details of enclosures below the first floor. Also _____

- Subdivision or other development plans (If the subdivision or development exceeds 50 lots or 5 acres, whichever is the lesser, the applicant must provide 100-year flood elevations if they are not otherwise available).
- Plans showing the extent of watercourse relocation and/or landform alterations.
- Top of new fill elevation _____ Ft. NGVD (MSL).
For floodproofing structures applicant must attach certification from registered engineer or architect.
- Certification from a registered engineer that the proposed activity in a regulatory floodway will not result in any increase in the height of the 100-year flood. A copy of all data and calculations supporting this finding must also be submitted.
- Manufactured homes located in a floodplain area must have a West Virginia Contractor's License and a Manufactured Home Installation License as required by the Federal Emergency Management Agency (FEMA).

Other:

SECTION 5: PERMIT DETERMINATION (To be completed by Floodplain Administrator/Manager or his/her representative)

I have determined that the proposed activity (type is or is not) in conformance with provisions of the Floodplain Ordinance adopted by the County Commission of Doddridge County on May 21, 2013. The permit is issued subject to the conditions attached to and made part of this permit.

SIGNED *Dan Williams* DATE 06/25/2013

If the Floodplain Administrator/Manager found that the above was not in conformance with the provisions of the Doddridge County Floodplain Ordinance and/or denied that application, the applicant may complete an appealing process below.

APPEALS: Appealed to the County Commission of Doddridge County? Yes No
Hearing Date: _____
County Commission Decision - Approved Yes No

CONDITIONS: _____

SECTION 6: AS-BUILT ELEVATIONS (To be submitted by APPLICANT before Certificate of Compliance is issued).

The following information must be provided for project structures. This section must be completed by a registered professional engineer or a licensed land surveyor (or attach a certification to this application).

COMPLETE 1 OR 2 BELOW:

- 1 Actual (As-Built) Elevation of the top of the lowest floor (including basement or crawl space is _____ FT. NGVD (MSL)
- 2 Actual (As Built) elevation of floodproofing is _____ FT. NGVD (MSL)

Note: Any work performed prior to submittal of the above information is at risk of the applicant.

SECTION 7: COMPLIANCE ACTION (To be completed by the Floodplain Administrator/Manager or his/her representative).

The Floodplain Administrator/Manager or his/her representative will complete this section as applicable based on inspection of the project to ensure compliance with the Doddridge County Floodplain Ordinance.

INSPECTIONS:

DATE: _____ BY: _____
DEFICIENCIES ? Y/N

COMMENTS _____

SECTION 8: CERTIFICATE OF COMPLIANCE (To be completed by Floodplain Administrator/Manager or his/her representative).

Certificate of Compliance issued: DATE: _____ BY: _____

**CERTIFICATE OF COMPLIANCE
FOR DEVELOPMENT IN SPECIAL FLOOD HAZARD AREA
(OWNER MUST RETAIN)**

PERMIT NUMBER: 13-015

PERMIT DATE: 6/25/2013

PURPOSE –

CONSTRUCTION LOCATION: _____

OWNER'S ADDRESS: _____

**THE FOLLOWING MUST BE COMPLETED BY THE FLOODPLAIN
ADMINISTRATOR/MANAGER OR HIS/HER AGENT.**

**COMPLIANCE IS HEREBY CERTIFIED WITH THE REQUIREMENT OF THE
FLOODPLAIN ORDINANCE ADOPTED BY THE COUNTY COMMISSION OF
DODDRIDGE COUNTY ON MAY 21, 2013.**

SIGNED *Dan Kelly* DATE 06/25/2013

ANTERO RESOURCES APPALACHIAN CORPORATION
SCHEDULE OF QUANTITIES
HINTER HEIRS NORTH
CENTRALIZED FRESHWATER IMPOUNDMENT

CLEARING & GRUBBING; EROSION & SEDIMENT CONTROLS				
	QUANTITY	UNIT		
MOBILIZATION	0.5	EA	\$16,000.00	\$8,000.00
CONSTRUCTION ENTRANCE	0.0	EA	\$4,033.30	\$0.00
CLEARING & GRUBBING (OPEN FIELD)	0.0	AC	\$2,200.00	\$0.00
CLEARING & GRUBBING (TREE REMOVAL)	4.7	AC	\$4,333.30	\$20,496.51
8" COMPOST FILTER SOCK	0.0	LF		\$0.00
12" COMPOST FILTER SOCK	315.8	LF	\$4.30	\$1,357.94
18" COMPOST FILTER SOCK	245.0	LF	\$7.60	\$1,862.00
24" COMPOST FILTER SOCK	25.6	LF	\$9.80	\$250.88
32" COMPOST FILTER SOCK	0.0	LF	\$14.50	\$0.00
SUPER SILT FENCE	0.0	LF	\$8.10	\$0.00
9" STRAW WATTLES	0.0	LF		\$0.00
TOTAL				\$31,967.33
SITE				
	QUANTITY	UNIT		
DRILL PAD EXCAVATION	0.0	CY		\$0.00
ACCESS ROADS EXCAVATION	0.0	CY	\$3.50	\$0.00
TURNAROUND PAD and/or CENTRALIZED IMPOUNDMENT EXCAVATION	27324.8	CY	\$3.50	\$95,636.80
TOPSOIL	2367.5	CY	\$3.30	\$7,812.75
DIVERSION DITCH	0.0	LF	\$2.00	\$0.00
ROADSIDE DITCH	0.0	LF	\$3.70	\$0.00
TOTAL				\$103,449.55
SUMP(S) PER ANTERO RESOURCES STANDARD DETAIL				
	QUANTITY	UNIT		
INSTALL 102" x 78" x 44" PRE CAST SUMP	0.0	EA		\$0.00
VALVE BOX HDPE PIPE (MINIMUM 12" DIAMETER x 48" HEIGHT)	0.0	EA		\$0.00
4" PVC CONNECTIVE PIPE (ANTERO SUMP DRAIN DETAIL)	0.0	LF		\$0.00
TOTAL				\$0.00
AGGREGATE SURFACING - SPREADING, COMPACTION, and/or INSTALLATION				
	QUANTITY	UNIT		
DRILL PAD AASHTO #1 (6" THICK)	0.0	TON		\$0.00
DRILL PAD 1 1/2" or 3/4" CRUSHER RUN STONE (2" THICK)	0.0	TON		\$0.00
DRILL PAD GEOTEXTILE FABRIC (US 200)	0.0	SY		\$0.00
ACCESS ROADS 2-3" AGGREGATE (6" THICK)	0.0	TON	\$9.40	\$0.00
ACCESS ROADS GEOTEXTILE FABRIC (US 200)	0.0	SY	\$0.90	\$0.00
*INSTALL TENSAR TX190 GEOGRID or EQUIVALENT	0.0	SY	\$2.50	\$0.00
TURNAROUND PAD 3" AGGREGATE (6" THICK)	190.1	TON	\$2.60	\$494.26
TURNAROUND PAD GEOTEXTILE FABRIC (US 200)	253.5	SY	\$2.00	\$507.00
*INSTALL TENSAR TX190 GEOGRID or EQUIVALENT	0.0	SY		\$0.00
TOTAL				\$1,001.26

ANTERO RESOURCES APPALACHIAN CORPORATION
SCHEDULE OF QUANTITIES
HINTER HEIRS NORTH
CENTRALIZED FRESHWATER IMPOUNDMENT

ROAD CULVERTS				
	QUANTITY	UNIT		
15" HDPE	0.0	LF	\$24.30	\$0.00
18" HDPE	0.0	LF		\$0.00
24" HDPE	0.0	LF		\$0.00
30" HDPE	0.0	LF		\$0.00
36" HDPE	0.0	LF		\$0.00
42" HDPE	0.0	LF		\$0.00
48" HDPE	0.0	LF		\$0.00
60" HDPE	0.0	LF		\$0.00
R4 RIP RAP (INLETS/OUTLETS)	0.0	TON	\$9.00	\$0.00
AASHTO #1 STONE (DITCH CHECKS)	0.0	TON	\$48.30	\$0.00
DITCH LINING - (ACCESS ROAD) SYNTHETIC MATTING (TRM)	0.0	SY		\$0.00
DITCH LINING - (ACCESS ROAD)	0.0	SY		\$0.00
DITCH LINING - (ACCESS ROAD) R4 RIP-RAP	0.0	TON	\$21.70	\$0.00
TOTAL				\$0.00
LINER SYSTEM*				
	QUANTITY	UNIT		
60 MIL TEXTURED PRIMARY LINER	7932.2	SY		\$0.00
16 OZ. NON-WOVEN GEOTEXTILE FABRIC CUSHION	7932.2	SY		\$0.00
TOTAL				\$0.00
*THE SQUARE YARDAGE FOR THE LINER SYSTEM DOES NOT ACCOUNT FOR MATERIAL OVERLAP AND WASTE.				
FENCING/GATES				
	QUANTITY	UNIT		
4 FT WOVEN WIRE FARM FENCE w/MINIMUM 10 FT POST SPACING (WOODEN and/or "T" POST	1018.2	LF	\$16.80	\$17,105.76
16 FT DOUBLE GATE	1.0	EA	\$650.00	\$650.00
TOTAL				\$17,755.76
SEEDING				
	QUANTITY	UNIT		
SITE SEEDING (LIME, FERTILIZER, SEEDING, AND HYDRO-MULCH w/TACK (HYC-2 OR EQUAL))	4.7	AC	\$3,400.00	\$16,082.00
TOTAL				\$16,082.00
UNFORESEEN SITE CONDITIONS				
	QUANTITY	UNIT		
*ROCK CLAUSE - BLASTING	0.0	CY	\$5.20	\$0.00
*ROCK CLAUSE - HOE RAMMING	0.0	CY	\$75.80	\$0.00
*FRENCH DRAINS	0.0	FT	\$10.00	\$0.00
*ORANGE SAFETY FENCE w/"T" POST (10FT CENTERS) - WETLAND PROTECTION	0.0	LF	\$9.40	\$0.00
*STEEL PANELS w/"T" POST (10 FT CENTERS) - WETLAND PROTECTION	0.0	LF	\$9.50	\$0.00
*SILT FENCE	0.0	LF	\$4.00	\$0.00
*TEMPORARY SEEDING	3.0	AC	\$1,900.00	\$5,696.04
*CONSTRUCTION STAKEOUT	0.0	HOUR	\$171.00	\$0.00
* JUTE MATTING - SLOPE MATTING	7703.3	SY	\$1.60	\$12,325.21
TOTAL				\$18,021.25
GRAND TOTAL				\$188,277.15



west virginia department of environmental protection

Office of Oil and Gas
601 57th Street SE
Charleston, WV 25304
Telephone: (304) 926-0499
Fax: (304) 926-0456

Earl Ray Tomblin, Governor
Randy C. Huffman, Cabinet Secretary
www.dep.wv.gov

Date 19 April 2013
**CERTIFICATE OF APPROVAL
CENTRALIZED FRESHWATER IMPOUNDMENT**

This certificate of approval, number 017-FWC-00001, issued to **Antero Resources Appalachian Corp for the Hinter Heirs North Fresh Water Centralized Impoundment**, is evidence of permission granted to construct a centralized freshwater impoundment pursuant to conditions described in W.Va Code §22-6A. The term of certificate of approval is for one year. The certificate of approval may be extended annually with the submission of an annual registration fee, provided the Office of Oil and Gas has on file an up-to-date inspection report, monitoring and emergency plan, maintenance plan, and no outstanding violations of certificate requirements exist. Construction of the impoundment will be located as described in the application. Design, construction, inspection and as-built certification will be the responsibility of, and under the supervision of, a professional engineer, registered in West Virginia.

Please be advised that notification to the landowner is required per W.Va Code §22-6A-10(h) within 7 days but no less than 2 days prior to commencement of construction. The Office of Oil and Gas as well as the oil and gas inspector must be notified. The filling of the impoundment with waters of the state will be subject to conditions of an approved Water Management Plan. Any deviation from conditions of the Water Management Plan will require prior approval from the Division of Water and Waste Management. Only freshwater may be stored in this impoundment. Addition of any wastewater will be in violation of the terms of this approval and may result in revocation of the certificate of approval. Any plans to enlarge, alter, repair, remove or abandon this structure will require a Certificate of Approval from the Office of Oil and Gas. An as built certification (IMP-3) must be submitted and received by the Office of Oil Gas prior to placing any fluids in this structure. Additional conditions as provide for in West Virginia Code §22-6A-9(h) are attached.



James Martin
Chief

Promoting a healthy environment.

Certificate of Approval CONDITIONS

West Virginia Code § 22-6A-9(h) allows the Office of Oil and Gas to place specific conditions upon this Certificate of Approval and have the same effect as law. Failure to adhere to the specified conditions may result in enforcement action.

CONDITIONS

1. The impoundment shall be monitored continuously during the initial filling operation.
2. Impoundment will be inspected every two weeks for the life of the impoundment and within 24 hours of a rainfall of two inches or greater in a six hour period. The attached form shall be used to document all inspections performed on the structure.

west virginia department of environmental protection



Water Management Plan: Primary Water Sources



WMP-01079

API/ID Number: 017-FWC-00001

Operator:

Antero Resources

Hinter Heirs North Centralized Freshwater Impoundment

Important:

For each proposed primary water source (including source intakes for purchased water sources) identified in your water management plan, and summarized herein, DEP has made an evaluation concerning water availability over the specified date range. DEP's assessment is based on the following considerations:

- Statistical analysis of historical USGS stream gauge data (transferred to un-gauged locations as necessary);
- Identification of sensitive aquatic life (endangered species, mussels, etc.);
- Quantification of known existing demands on the water supply (Large Quantity Users);
- Minimum flows required by the Army Corps of Engineers; and
- Designated stream uses.

Based on these factors, DEP has provided, for each intake location (and origination point for purchased water), a reference gauge location and discharge flow reading which must be surpassed prior to withdrawals. Additionally, DEP has established a minimum passby flow at the withdrawal location which must also be surpassed prior to withdrawals. These thresholds are considered terms of the permit and are enforceable as such.

DEP is aware that some intake points will be used for multiple wells and well sites. In these cases, the thresholds set by the Water Management Plan are to be interpreted as total withdrawal limits for each location over the specified date range regardless of how many wells are supported by that intake.

For all purchased water intakes, determinations of water availability are made at the original source intake location. It is the responsibility of the Oil and Gas Operator, not the seller, to cease withdrawal of water from the seller when flows are less than the minimum gauge reading at the stream gauge referenced by the Water Management Plan in order to protect stream uses.

Note that the determinations made herein are based on the best available data, but it is impossible to predict water availability in the future. While the DEP has carefully established these minimum withdrawal thresholds, it remains the operator's responsibility to protect aquatic life at all times. Approval to withdrawal is contingent upon permission from the land owner. It is the responsibility of the operator to secure and maintain permission prior to any withdrawals.

The operator is reminded that 24-48 hours prior to withdrawing (or purchasing) water, DEP must be notified by email at DEP.water.use@wv.gov.

APPROVED APR 02 2013

Source Summary

WMP: 01079

API Number: 017-FWC-00001

Operator:

Antero Resources

Hinter Heirs North Centralized Freshwater Impoundment

Stream/River

Source **West Fork River @ JCP Withdrawal** Owner: **James & Brenda Raines**

Start Date End Date Total Volume (gal) Max. daily purchase (gal) Intake Latitude: Intake Longitude:
3/29/2013 3/29/2015 39.320913 -80.337572

Regulated Stream? Stonewall Jackson Dam Ref. Gauge ID: 3061000 WEST FORK RIVER AT ENTERPRISE, WV

Max. Pump rate (gpm): **2,000** Min. Gauge Reading (cfs): **175.00** Min. Passby (cfs) **146.25**

DEP Comments:

Source **West Fork River @ McDonald Withdrawal** Owner: **David Shrieves**

Start Date End Date Total Volume (gal) Max. daily purchase (gal) Intake Latitude: Intake Longitude:
3/29/2013 3/29/2015 39.16761 -80.45069

Regulated Stream? Stonewall Jackson Dam Ref. Gauge ID: 3061000 WEST FORK RIVER AT ENTERPRISE, WV

Max. Pump rate (gpm): **3,000** Min. Gauge Reading (cfs): **175.00** Min. Passby (cfs) **106.30**

DEP Comments:

Source **West Fork River @ GAL Withdrawal** Owner: **David Shrieves**

Start Date End Date Total Volume (gal) Max. daily purchase (gal) Intake Latitude: Intake Longitude:
3/29/2013 3/29/2015 39.16422 -80.45173

Regulated Stream? Stonewall Jackson Dam Ref. Gauge ID: 3061000 WEST FORK RIVER AT ENTERPRISE, WV

Max. Pump rate (gpm): **2,000** Min. Gauge Reading (cfs): **175.00** Min. Passby (cfs) **106.30**

DEP Comments:

APPROVED APR 02 2013

● Source **Middle Island Creek @ Dawson Withdrawal**

Owner: **Gary D. and Rella A. Dawson**

Start Date	End Date	Total Volume (gal)	Max. daily purchase (gal)	Intake Latitude:	Intake Longitude:
3/29/2013	3/29/2015			39.379292	-80.867803

Regulated Stream? Ref. Gauge ID: 3114500 MIDDLE ISLAND CREEK AT LITTLE, WV

Max. Pump rate (gpm): **3,000** Min. Gauge Reading (cfs): **76.03** Min. Passby (cfs) **28.83**

DEP Comments:

● Source **McElroy Creek @ Forest Withdrawal**

Owner: **Forest C. & Brenda L. Moore**

Start Date	End Date	Total Volume (gal)	Max. daily purchase (gal)	Intake Latitude:	Intake Longitude:
3/29/2013	3/29/2015			39.39675	-80.738197

Regulated Stream? Ref. Gauge ID: 3114500 MIDDLE ISLAND CREEK AT LITTLE, WV

Max. Pump rate (gpm): **1,000** Min. Gauge Reading (cfs): **74.77** Min. Passby (cfs) **13.10**

DEP Comments:

● Source **McElroy Creek @ Sweeney Withdrawal**

Owner: **Bill Sweeney**

Start Date	End Date	Total Volume (gal)	Max. daily purchase (gal)	Intake Latitude:	Intake Longitude:
3/29/2013	3/29/2015			39.398123	-80.656808

Regulated Stream? Ref. Gauge ID: 3114500 MIDDLE ISLAND CREEK AT LITTLE, WV

Max. Pump rate (gpm): **1,000** Min. Gauge Reading (cfs): **69.73** Min. Passby (cfs) **6.66**

DEP Comments:

APPROVED APR 3 2013

* Source **Meathouse Fork @ Gagnon Withdrawal** Owner: **George L. Gagnon and Susan C. Gagnon**

Start Date	End Date	Total Volume (gal)	Max. daily purchase (gal)	Intake Latitude:	Intake Longitude:
3/29/2013	3/29/2015			39.26054	-80.720998

Regulated Stream? Ref. Gauge ID: **3114500** MIDDLE ISLAND CREEK AT LITTLE, WV

Max. Pump rate (gpm):	1,000	Min. Gauge Reading (cfs):	71.96	Min. Passby (cfs)	13.10
-----------------------	--------------	---------------------------	--------------	-------------------	--------------

DEP Comments:

o Source **Meathouse Fork @ Whitehair Withdrawal** Owner: **Elton Whitehair**

Start Date	End Date	Total Volume (gal)	Max. daily purchase (gal)	Intake Latitude:	Intake Longitude:
3/29/2013	3/29/2015			39.211317	-80.679592

Regulated Stream? Ref. Gauge ID: **3114500** MIDDLE ISLAND CREEK AT LITTLE, WV

Max. Pump rate (gpm):	1,000	Min. Gauge Reading (cfs):	69.73	Min. Passby (cfs)	7.28
-----------------------	--------------	---------------------------	--------------	-------------------	-------------

DEP Comments:

* Source **Tom's Fork @ Erwin Withdrawal** Owner: **John F. Erwin and Sandra E. Erwin**

Start Date	End Date	Total Volume (gal)	Max. daily purchase (gal)	Intake Latitude:	Intake Longitude:
3/29/2013	3/29/2015			39.174306	-80.702992

Regulated Stream? Ref. Gauge ID: **3114500** MIDDLE ISLAND CREEK AT LITTLE, WV

Max. Pump rate (gpm):	1,000	Min. Gauge Reading (cfs):	69.73	Min. Passby (cfs)	0.59
-----------------------	--------------	---------------------------	--------------	-------------------	-------------

DEP Comments:

● Source **Arnold Creek @ Davis Withdrawal** Owner: **Jonathon Davis**

Start Date	End Date	Total Volume (gal)	Max. daily purchase (gal)	Intake Latitude:	Intake Longitude:
3/29/2013	3/29/2015			39.302006	-80.824561

Regulated Stream? Ref. Gauge ID: **3114500** MIDDLE ISLAND CREEK AT LITTLE, WV

Max. Pump rate (gpm): **1,000** Min. Gauge Reading (cfs): **69.73** Min. Passby (cfs) **3.08**

DEP Comments:

● Source **Buckeye Creek @ Powell Withdrawal** Owner: **Dennis Powell**

Start Date	End Date	Total Volume (gal)	Max. daily purchase (gal)	Intake Latitude:	Intake Longitude:
3/29/2013	3/29/2015			39.277142	-80.690386

Regulated Stream? Ref. Gauge ID: **3114500** MIDDLE ISLAND CREEK AT LITTLE, WV

Max. Pump rate (gpm): **1,000** Min. Gauge Reading (cfs): **69.73** Min. Passby (cfs) **4.59**

DEP Comments:

● Source **South Fork of Hughes River @ Knight Withdrawal** Owner: **Tracy C. Knight & Stephanie C. Knight**

Start Date	End Date	Total Volume (gal)	Max. daily purchase (gal)	Intake Latitude:	Intake Longitude:
3/29/2013	3/29/2015			39.198369	-80.870969

Regulated Stream? Ref. Gauge ID: **3155220** SOUTH FORK HUGHES RIVER BELOW MACFARLAN, WV

Max. Pump rate (gpm): **3,000** Min. Gauge Reading (cfs): **39.80** Min. Passby (cfs) **1.95**

DEP Comments:

3/29/2013

o Source **North Fork of Hughes River @ Davis Withdrawal** Owner: **Lewis P. Davis and Normal J. Davis**

Start Date End Date Total Volume (gal) Max. daily purchase (gal) Intake Latitude: Intake Longitude:
3/29/2013 3/29/2015 39.322363 -80.936771

Regulated Stream? Ref. Gauge ID: 3155220 SOUTH FORK HUGHES RIVER BELOW MACFARLAN, WA

Max. Pump rate (gpm): **1,000** Min. Gauge Reading (cfs): **35.23** Min. Passby (cfs) **2.19**

DEP Comments:

Source Summary

WMP-01079 API Number: 017-FWC-00001 Operator: Antero Resources
Hinter Heirs North Centralized Freshwater Impoundment

Purchased Water

o Source **Middle Island Creek @ Solo Construction** Owner: **Solo Construction, LLC**

Start Date End Date Total Volume (gal) Max. daily purchase (gal) Intake Latitude: Intake Longitude:
3/29/2013 3/29/2015 1,000,000 39.399094 -81.185548

Regulated Stream? Ohio River Min. Flow Ref. Gauge ID: 9999999 Ohio River Station: Willow Island Lock & Dam

Max. Pump rate (gpm): Min. Gauge Reading (cfs): **6,468.00** Min. Passby (cfs)

DEP Comments: Elevation analysis indicates that this location has the same elevation as Middle Island Creek's pour point into the Ohio River. As such, it is deemed that water flow at this location is heavily influenced by the Ohio River.

o Source **Sun Valley Public Service District** Owner: **Sun Valley PSD**

Start Date End Date Total Volume (gal) Max. daily purchase (gal) Intake Latitude: Intake Longitude:
3/29/2013 3/29/2015 200,000 - -

Regulated Stream? Stonewall Jackson Dam Ref. Gauge ID: 3061000 WEST FORK RIVER AT ENTERPRISE, WV

Max. Pump rate (gpm): Min. Gauge Reading (cfs): **171.48** Min. Passby (cfs)

DEP Comments:

Source Detail

WMP-01079

API/ID Number: 017-FWC-00001

Operator:

Antero Resources

Hinter Heirs North Centralized Freshwater Impoundment

Source ID: 13832 Source Name: Middle Island Creek @ Solo Construction
Solo Construction, LLC

Source Latitude: 39.399094
Source Longitude: -81.185548

HUC-8 Code: 5030201

Drainage Area (sq. mi.): 25000 County: Pleasants

Anticipated withdrawal start date: 3/29/2013

Anticipated withdrawal end date: 3/29/2015

Endangered Species? Mussel Stream?

Trout Stream? Tier 3?

Regulated Stream? Ohio River Min. Flow

Proximate PSD? City of St. Marys

Gauged Stream?

Total Volume from Source (gal):

Max. Pump rate (gpm):

Max. Simultaneous Trucks:

Max. Truck pump rate (gpm) 0

Reference Gaug 9999999 Ohio River Station: Willow Island Lock & Dam

Drainage Area (sq. mi.) 25,000.00

Gauge Threshold (cfs): 6468

Month	Median monthly flow (cfs)	Threshold (+ pump)	Estimated Available water (cfs)
1	45,700.00	-	-
2	49,200.00	-	-
3	65,700.00	-	-
4	56,100.00	-	-
5	38,700.00	-	-
6	24,300.00	-	-
7	16,000.00	-	-
8	13,400.00	-	-
9	12,800.00	-	-
10	15,500.00	-	-
11	26,300.00	-	-
12	41,300.00	-	-

Water Availability Profile

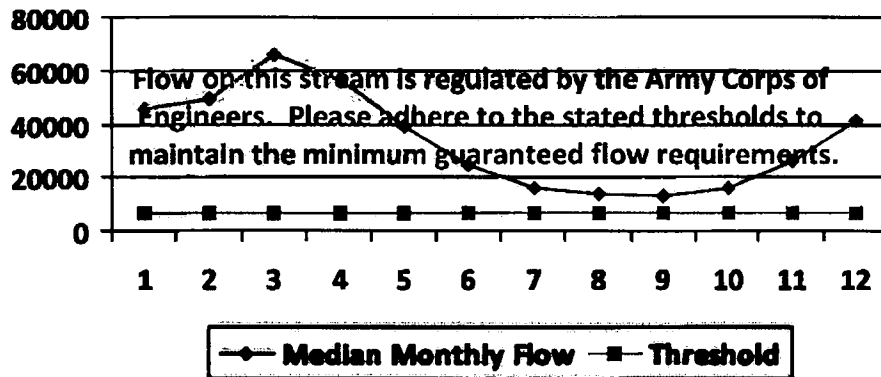

Water Availability Assessment of Location

Base Threshold (cfs):	-
Upstream Demand (cfs):	0.00
Downstream Demand (cfs):	0.00
Pump rate (cfs):	
Headwater Safety (cfs):	0.00
Ungauged Stream Safety (cfs):	0.00
<hr/>	
Min. Gauge Reading (cfs):	-
Passby at Location (cfs):	-

"Threshold", as depicted in the chart above is meant only to indicate the calculated base threshold at the proposed withdrawal location. This value does not include the proposed pump rate or existing demand on the stream. Refer to the monthly breakdown above for a more complete estimation of water availability by month.

Source Detail

WMP-01079

API/ID Number: 017-FWC-00001

Operator:

Antero Resources

Hinter Heirs North Centralized Freshwater Impoundment

Source ID: 13850 Source Name: Sun Valley Public Service District
Sun Valley PSD

Source Latitude: -
Source Longitude: -

HUC-8 Code: 5020002

Drainage Area (sq. mi.): 391.85 County: Harrison

Anticipated withdrawal start date: 3/29/2013

Anticipated withdrawal end date: 3/29/2015

- Endangered Species? Mussel Stream?
- Trout Stream? Tier 3?
- Regulated Stream? Stonewall Jackson Dam
- Proximate PSD?
- Gauged Stream?

Total Volume from Source (gal):

Max. Pump rate (gpm):

Max. Simultaneous Trucks:

Max. Truck pump rate (gpm)

Reference Gaug: 3061000 WEST FORK RIVER AT ENTERPRISE, WV

Drainage Area (sq. mi.): 759.00

Gauge Threshold (cfs): 234

Month	Median monthly flow (cfs)	Threshold (+ pump)	Estimated Available water (cfs)
1	1,200.75	-	-
2	1,351.92	-	-
3	1,741.33	-	-
4	995.89	-	-
5	1,022.23	-	-
6	512.21	-	-
7	331.86	-	-
8	316.87	-	-
9	220.48	-	-
10	216.17	-	-
11	542.45	-	-
12	926.12	-	-

Water Availability Profile

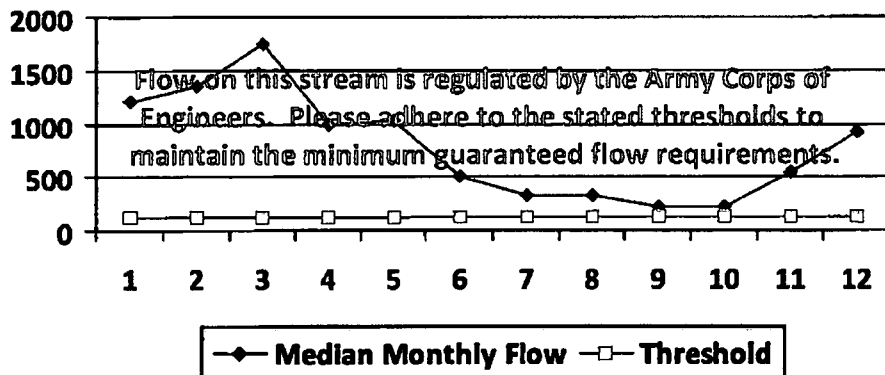

Water Availability Assessment of Location

- Base Threshold (cfs): -
- Upstream Demand (cfs):
- Downstream Demand (cfs):
- Pump rate (cfs):
- Headwater Safety (cfs): 0.00
- Ungauged Stream Safety (cfs): 0.00

- Min. Gauge Reading (cfs): -
- Passby at Location (cfs): -

"Threshold", as depicted in the chart above is meant only to indicate the calculated base threshold at the proposed withdrawal location. This value does not include the proposed pump rate or existing demand on the stream. Refer to the monthly breakdown above for a more complete estimation of water availability by month.

Source Detail

WMP-01079

API/ID Number: 017-FWC-00001

Operator:

Antero Resources

Hinter Heirs North Centralized Freshwater Impoundment

Source ID: 13819 Source Name: West Fork River @ JCP Withdrawal
James & Brenda Raines

Source Latitude: 39.320913
Source Longitude: -80.337572

HUC-8 Code: 5020002

Drainage Area (sq. mi.): 532.2 County: Harrison

Anticipated withdrawal start date: 3/29/2013

Anticipated withdrawal end date: 3/29/2015

Endangered Species? Mussel Stream?

Trout Stream? Tier 3?

Regulated Stream? Stonewall Jackson Dam

Proximate PSD?

Gauged Stream?

Total Volume from Source (gal):

Max. Pump rate (gpm): 2,000

Max. Simultaneous Trucks: 0

Max. Truck pump rate (gpm): 0

Reference Gaug: 3061000 WEST FORK RIVER AT ENTERPRISE, WV

Drainage Area (sq. mi.): 759.00

Gauge Threshold (cfs): 234

Month	Median monthly flow (cfs)	Threshold (+ pump)	Estimated Available water (cfs)
1	1,630.82	-	-
2	1,836.14	-	-
3	2,365.03	-	-
4	1,352.59	-	-
5	1,388.37	-	-
6	695.67	-	-
7	450.73	-	-
8	430.37	-	-
9	299.45	-	-
10	293.59	-	-
11	736.74	-	-
12	1,257.84	-	-

Water Availability Profile

Water Availability Assessment of Location

Base Threshold (cfs):	-
Upstream Demand (cfs):	24.29
Downstream Demand (cfs):	0.00
Pump rate (cfs):	4.46
Headwater Safety (cfs):	0.00
Ungauged Stream Safety (cfs):	0.00

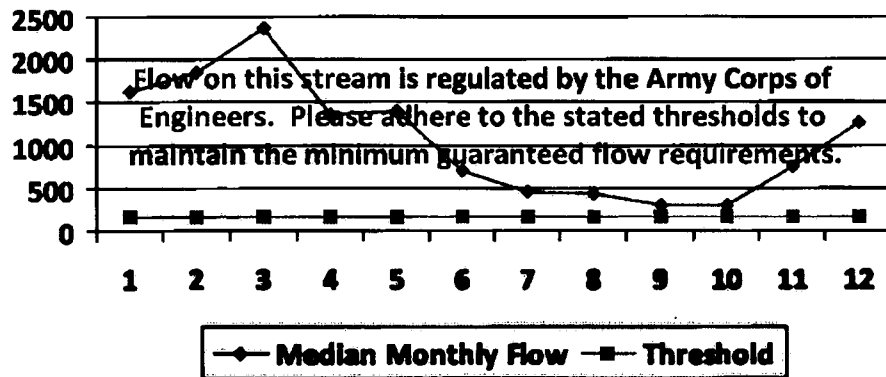

Min. Gauge Reading (cfs):	-
Passby at Location (cfs):	-

"Threshold", as depicted in the chart above is meant only to indicate the calculated base threshold at the proposed withdrawal location. This value does not include the proposed pump rate or existing demand on the stream. Refer to the monthly breakdown above for a more complete estimation of water availability by month.

Source Detail

WMP-01079

API/ID Number: 017-FWC-00001

Operator:

Antero Resources

Hinter Heirs North Centralized Freshwater Impoundment

Source ID: 13820 Source Name: West Fork River @ McDonald Withdrawal
David Shrieves

Source Latitude: 39.16761
Source Longitude: -80.45069

HUC-8 Code: 5020002

Drainage Area (sq. mi.): 314.91 County: Harrison

Anticipated withdrawal start date: 3/29/2013
Anticipated withdrawal end date: 3/29/2015

- Endangered Species? Mussel Stream?
- Trout Stream? Tier 3?
- Regulated Stream? Stonewall Jackson Dam
- Proximate PSD?
- Gauged Stream?

Total Volume from Source (gal):

Max. Pump rate (gpm): 3,000
Max. Simultaneous Trucks: 0
Max. Truck pump rate (gpm): 0

Reference Gaug: 3061000 WEST FORK RIVER AT ENTERPRISE, WV

Drainage Area (sq. mi.): 759.00

Gauge Threshold (cfs): 234

Month	Median monthly flow (cfs)	Threshold (+ pump)	Estimated Available water (cfs)
1	964.98	-	-
2	1,086.47	-	-
3	1,399.42	-	-
4	800.34	-	-
5	821.52	-	-
6	411.64	-	-
7	266.70	-	-
8	254.66	-	-
9	177.19	-	-
10	173.72	-	-
11	435.94	-	-
12	744.28	-	-

Water Availability Profile

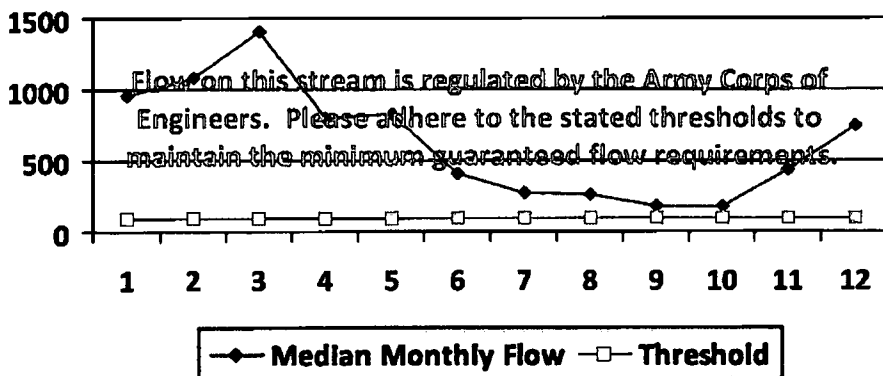

Water Availability Assessment of Location

Base Threshold (cfs):	-
Upstream Demand (cfs):	24.29
Downstream Demand (cfs):	0.00
Pump rate (cfs):	6.68
Headwater Safety (cfs):	24.27
Ungauged Stream Safety (cfs):	0.00
Min. Gauge Reading (cfs):	-
Passby at Location (cfs):	-

"Threshold", as depicted in the chart above is meant only to indicate the calculated base threshold at the proposed withdrawal location. This value does not include the proposed pump rate or existing demand on the stream. Refer to the monthly breakdown above for a more complete estimation of water availability by month.

Source Detail

WMP-01079

API/D Number: 017-FWC-00001

Operator:

Antero Resources

Hinter Heirs North Centralized Freshwater Impoundment

Source ID: 13821 Source Name: West Fork River @ GAL Withdrawal
David Shrieves

Source Latitude: 39.16422
Source Longitude: -80.45173

HUC-8 Code: 5020002

Drainage Area (sq. mi.): 313.67 County: Harrison

Anticipated withdrawal start date: 3/29/2013

Anticipated withdrawal end date: 3/29/2015

- Endangered Species? Mussel Stream?
- Trout Stream? Tier 3?
- Regulated Stream? Stonewall Jackson Dam
- Proximate PSD?
- Gauged Stream?

Total Volume from Source (gal):

Max. Pump rate (gpm): 2,000

Max. Simultaneous Trucks: 0

Max. Truck pump rate (gpm): 0

Reference Gaug: 3061000 WEST FORK RIVER AT ENTERPRISE, WV

Drainage Area (sq. mi.): 759.00

Gauge Threshold (cfs): 234

Month	Median monthly flow (cfs)	Threshold (+ pump)	Estimated Available water (cfs)
1	961.18	-	-
2	1,082.19	-	-
3	1,393.91	-	-
4	797.19	-	-
5	818.28	-	-
6	410.02	-	-
7	265.65	-	-
8	253.65	-	-
9	176.49	-	-
10	173.04	-	-
11	434.22	-	-
12	741.35	-	-

Water Availability Profile

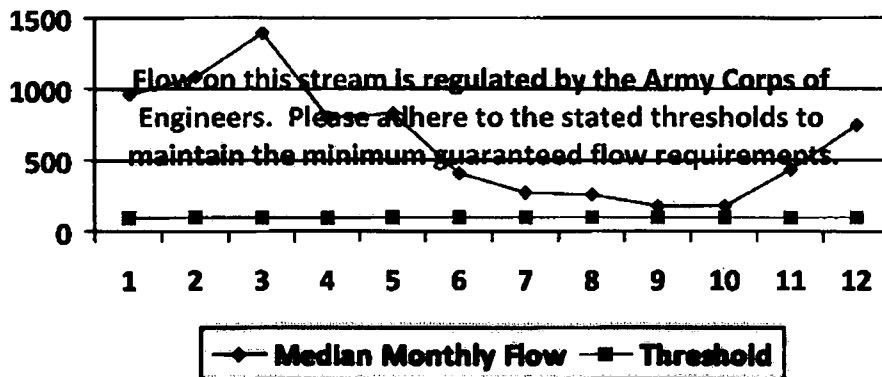

Water Availability Assessment of Location

Base Threshold (cfs): -
 Upstream Demand (cfs): 24.29
 Downstream Demand (cfs): 0.00
 Pump rate (cfs): 4.46
 Headwater Safety (cfs): 24.18
 Ungauged Stream Safety (cfs): 0.00

Min. Gauge Reading (cfs): -

Passby at Location (cfs): -

"Threshold", as depicted in the chart above is meant only to indicate the calculated base threshold at the proposed withdrawal location. This value does not include the proposed pump rate or existing demand on the stream. Refer to the monthly breakdown above for a more complete estimation of water availability by month.

Source Detail

WMP-01079

API/ID Number: 017-FWC-00001

Operator:

Antero Resources

Hinter Heirs North Centralized Freshwater Impoundment

Source ID: 13822 Source Name: Middle Island Creek @ Dawson Withdrawal
Gary D. and Rella A. Dawson

Source Latitude: 39.379292
Source Longitude: -80.867803

HUC-8 Code: 5030201

Drainage Area (sq. mi.): 181.34 County: Tyler

Anticipated withdrawal start date: 3/29/2013
Anticipated withdrawal end date: 3/29/2015

- Endangered Species? Mussel Stream?
- Trout Stream? Tier 3?
- Regulated Stream?
- Proximate PSD?
- Gauged Stream?

Total Volume from Source (gal):

Max. Pump rate (gpm): 3,000
Max. Simultaneous Trucks: 0
Max. Truck pump rate (gpm): 0

Reference Gaug: 3114500 MIDDLE ISLAND CREEK AT LITTLE, WV
Drainage Area (sq. mi.): 458.00

Gauge Threshold (cfs): 45

Month	Median monthly flow (cfs)	Threshold (+ pump)	Estimated Available water (cfs)
1	194.47	42.06	152.68
2	244.62	42.06	202.83
3	273.72	42.06	231.93
4	203.26	42.06	161.47
5	107.22	42.06	65.43
6	37.44	42.06	-4.35
7	21.19	42.06	-20.60
8	17.45	42.06	-24.34
9	8.94	42.06	-32.85
10	11.23	42.06	-30.56
11	54.82	42.06	13.04
12	133.96	42.06	92.17

Water Availability Profile

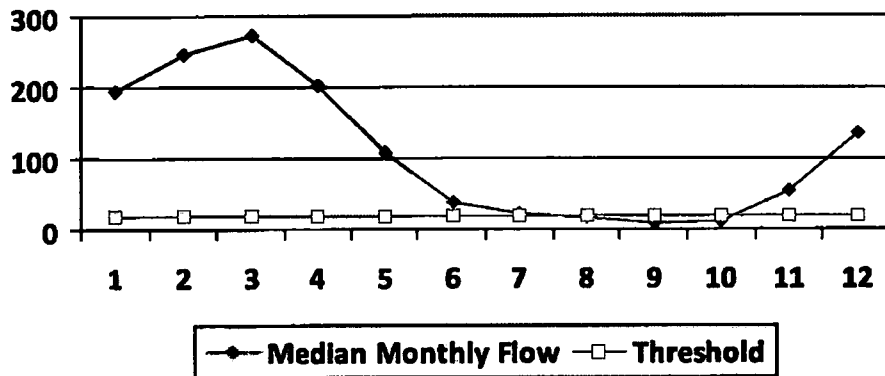

Water Availability Assessment of Location

Base Threshold (cfs): 17.82
 Upstream Demand (cfs): 13.10
 Downstream Demand (cfs): 6.55
 Pump rate (cfs): 6.68
 Headwater Safety (cfs): 4.45
 Ungauged Stream Safety (cfs): 0.00

Min. Gauge Reading (cfs): 76.03
 Passby at Location (cfs): 28.82

"Threshold", as depicted in the chart above is meant only to indicate the calculated base threshold at the proposed withdrawal location. This value does not include the proposed pump rate or existing demand on the stream. Refer to the monthly breakdown above for a more complete estimation of water availability by month.

Source Detail

WMP-01079

API/ID Number: 017-FWC-00001

Operator:

Antero Resources

Hinter Heirs North Centralized Freshwater Impoundment

Source ID: 13823 Source Name: McElroy Creek @ Forest Withdrawal
Forest C. & Brenda L. Moore

Source Latitude: 39.39675
Source Longitude: -80.738197

HUC-8 Code: 5030201

Drainage Area (sq. mi.): 88.85 County: Tyler

Anticipated withdrawal start date: 3/29/2013

Anticipated withdrawal end date: 3/29/2015

- Endangered Species? Mussel Stream?
- Trout Stream? Tier 3?
- Regulated Stream?
- Proximate PSD?
- Gauged Stream?

Total Volume from Source (gal):

Max. Pump rate (gpm): 1,000

Max. Simultaneous Trucks: 0

Max. Truck pump rate (gpm): 0

Reference Gaug: 3114500 MIDDLE ISLAND CREEK AT LITTLE, WV

Drainage Area (sq. mi.): 458.00

Gauge Threshold (cfs): 45

Month	<u>Median monthly flow (cfs)</u>	<u>Threshold (+ pump)</u>	<u>Estimated Available water (cfs)</u>
1	95.28	19.78	75.68
2	119.86	19.78	100.25
3	134.11	19.78	114.51
4	99.59	19.78	79.99
5	52.54	19.78	32.93
6	18.35	19.78	-1.26
7	10.38	19.78	-9.22
8	8.55	19.78	-11.05
9	4.38	19.78	-15.23
10	5.50	19.78	-14.10
11	26.86	19.78	7.26
12	65.63	19.78	46.03

Water Availability Profile

Water Availability Assessment of Location

Base Threshold (cfs): 8.73

Upstream Demand (cfs): 4.46

Downstream Demand (cfs): 0.00

Pump rate (cfs): 2.23

Headwater Safety (cfs): 2.18

Ungauged Stream Safety (cfs): 2.18

Min. Gauge Reading (cfs): 74.19

Passby at Location (cfs): 13.09

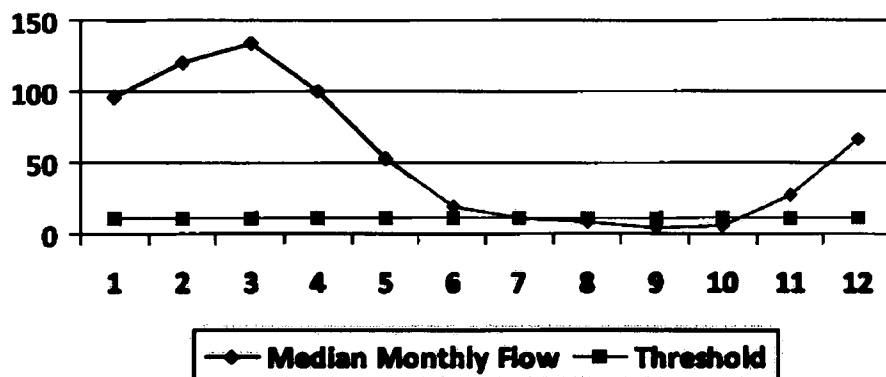

"Threshold", as depicted in the chart above is meant only to indicate the calculated base threshold at the proposed withdrawal location. This value does not include the proposed pump rate or existing demand on the stream. Refer to the monthly breakdown above for a more complete estimation of water availability by month.

Source Detail

WMP-01079

API/ID Number: 017-FWC-00001

Operator:

Antero Resources

Hinter Heirs North Centralized Freshwater Impoundment

Source ID: 13824 Source Name: McElroy Creek @ Sweeney Withdrawal
Bill Sweeney

Source Latitude: 39.398123
Source Longitude: -80.656808

HUC-8 Code: 5030201

Drainage Area (sq. mi.): 45.16 County: Doddridge

Anticipated withdrawal start date: 3/29/2013
Anticipated withdrawal end date: 3/29/2015

- Endangered Species? Mussel Stream?
- Trout Stream? Tier 3?
- Regulated Stream?
- Proximate PSD?
- Gauged Stream?

Total Volume from Source (gal):

Max. Pump rate (gpm): 1,000
Max. Simultaneous Trucks: 0
Max. Truck pump rate (gpm): 0

Reference Gaug: 3114500 MIDDLE ISLAND CREEK AT LITTLE, WV

Drainage Area (sq. mi.): 458.00

Gauge Threshold (cfs): 45

Month	<u>Median monthly flow (cfs)</u>	<u>Threshold (+ pump)</u>	<u>Estimated Available water (cfs)</u>
1	48.43	8.88	39.93
2	60.92	8.88	52.42
3	68.17	8.88	59.67
4	50.62	8.88	42.12
5	26.70	8.88	18.21
6	9.32	8.88	0.83
7	5.28	8.88	-3.22
8	4.34	8.88	-4.15
9	2.23	8.88	-6.27
10	2.80	8.88	-5.70
11	13.65	8.88	5.16
12	33.36	8.88	24.86

Water Availability Profile

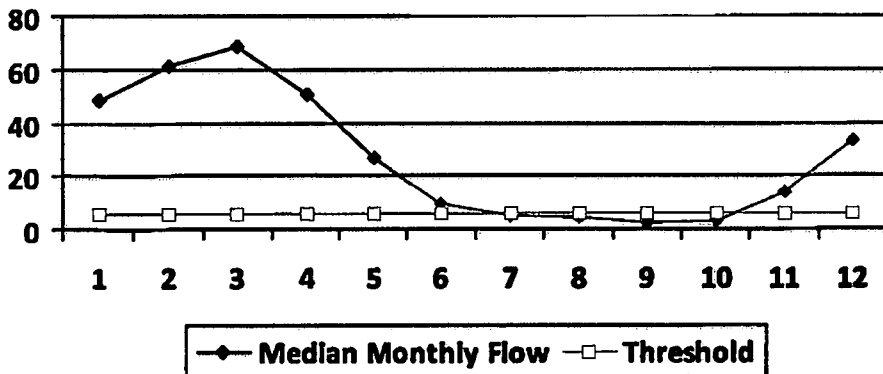

Water Availability Assessment of Location

Base Threshold (cfs): 4.44
Upstream Demand (cfs): 0.00
Downstream Demand (cfs): 0.00
Pump rate (cfs): 2.23
Headwater Safety (cfs): 1.11
Ungauged Stream Safety (cfs): 1.11

Min. Gauge Reading (cfs): 69.73
Passby at Location (cfs): 6.66

"Threshold", as depicted in the chart above is meant only to indicate the calculated base threshold at the proposed withdrawal location. This value does not include the proposed pump rate or existing demand on the stream. Refer to the monthly breakdown above for a more complete estimation of water availability by month.

Source Detail

WMP-01079

API/ID Number: 017-FWC-00001

Operator:

Antero Resources

Hinter Heirs North Centralized Freshwater Impoundment

Source ID: 13825 Source Name: Meathouse Fork @ Gagnon Withdrawal
George L. Gagnon and Susan C. Gagnon

Source Latitude: 39.26054
Source Longitude: -80.720998

HUC-8 Code: 5030201

Drainage Area (sq. mi.): 60.6 County: Doddridge

Anticipated withdrawal start date: 3/29/2013

Anticipated withdrawal end date: 3/29/2015

- Endangered Species? Mussel Stream?
- Trout Stream? Tier 3?
- Regulated Stream?
- Proximate PSD?
- Gauged Stream?

Total Volume from Source (gal):

Max. Pump rate (gpm): 1,000
Max. Simultaneous Trucks: 0
Max. Truck pump rate (gpm): 0

Reference Gaug: 3114500 MIDDLE ISLAND CREEK AT LITTLE, WV

Drainage Area (sq. mi.): 458.00 Gauge Threshold (cfs): 45

Month	<u>Median monthly flow</u> (cfs)	<u>Threshold</u> (+ pump)	<u>Estimated Available water</u> (cfs)
1	64.99	13.39	51.70
2	81.75	13.39	68.46
3	91.47	13.39	78.19
4	67.93	13.39	54.64
5	35.83	13.39	22.55
6	12.51	13.39	-0.77
7	7.08	13.39	-6.20
8	5.83	13.39	-7.45
9	2.99	13.39	-10.30
10	3.75	13.39	-9.53
11	18.32	13.39	5.04
12	44.76	13.39	31.48

Water Availability Profile

Water Availability Assessment of Location

Base Threshold (cfs): 5.95
Upstream Demand (cfs): 2.23
Downstream Demand (cfs): 2.81
Pump rate (cfs): 2.23
Headwater Safety (cfs): 1.49
Ungauged Stream Safety (cfs): 1.49

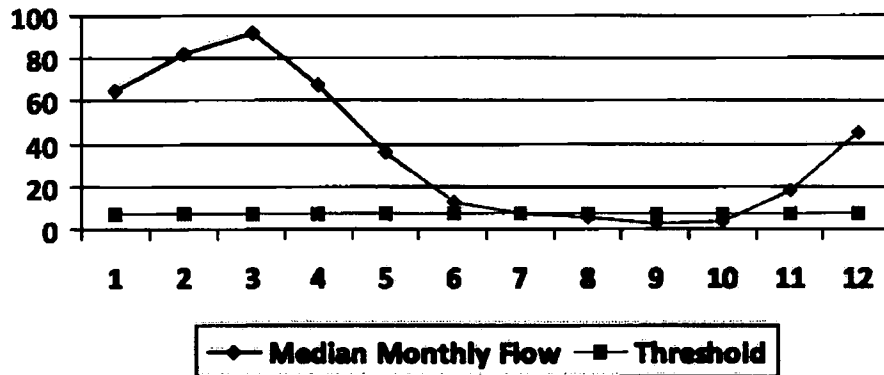

Min. Gauge Reading (cfs): 71.96
Passby at Location (cfs): 11.74

"Threshold", as depicted in the chart above is meant only to indicate the calculated base threshold at the proposed withdrawal location. This value does not include the proposed pump rate or existing demand on the stream. Refer to the monthly breakdown above for a more complete estimation of water availability by month.

Source Detail

WMP-01079

API/ID Number: 017-FWC-00001

Operator:

Antero Resources

Hinter Heirs North Centralized Freshwater Impoundment

Source ID: 13826 Source Name: Meathouse Fork @ Whitehair Withdrawal
Elton Whitehair

Source Latitude: 39.211317
Source Longitude: -80.679592

HUC-8 Code: 5030201

Drainage Area (sq. mi.): 30.37 County: Doddridge

Anticipated withdrawal start date: 3/29/2013
Anticipated withdrawal end date: 3/29/2015

- Endangered Species? Mussel Stream?
- Trout Stream? Tier 3?
- Regulated Stream?
- Proximate PSD?
- Gauged Stream?

Total Volume from Source (gal):

Max. Pump rate (gpm): 1,000
Max. Simultaneous Trucks: 0
Max. Truck pump rate (gpm): 0

Reference Gaug: 3114500 MIDDLE ISLAND CREEK AT LITTLE, WV
Drainage Area (sq. mi.): 458.00

Gauge Threshold (cfs): 45

Month	Median monthly flow (cfs)	Threshold (+ pump)	Estimated Available water (cfs)
1	32.57	6.70	26.15
2	40.97	6.70	34.55
3	45.84	6.70	39.42
4	34.04	6.70	27.62
5	17.96	6.70	11.54
6	6.27	6.70	-0.15
7	3.55	6.70	-2.87
8	2.92	6.70	-3.50
9	1.50	6.70	-4.92
10	1.88	6.70	-4.54
11	9.18	6.70	2.76
12	22.43	6.70	16.01

Water Availability Profile

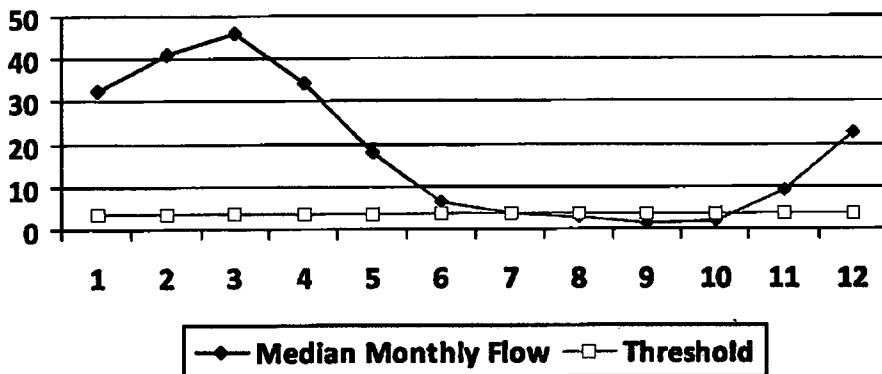

Water Availability Assessment of Location

Base Threshold (cfs): 2.98
Upstream Demand (cfs): 0.00
Downstream Demand (cfs): 2.81
Pump rate (cfs): 2.23
Headwater Safety (cfs): 0.75
Ungauged Stream Safety (cfs): 0.75

Mln. Gauge Reading (cfs): 69.73
Passby at Location (cfs): 7.29

"Threshold", as depicted in the chart above is meant only to indicate the calculated base threshold at the proposed withdrawal location. This value does not include the proposed pump rate or existing demand on the stream. Refer to the monthly breakdown above for a more complete estimation of water availability by month.

Source Detail

WMP-01079

API/ID Number: 017-FWC-00001

Operator:

Antero Resources

Hinter Heirs North Centralized Freshwater Impoundment

Source ID: 13827 Source Name: Tom's Fork @ Erwin Withdrawal
 John F. Erwin and Sandra E. Erwin

Source Latitude: 39.174306
 Source Longitude: -80.702992

HUC-8 Code: 5030201

Drainage Area (sq. mi.): 4.01 County: Doddridge

Anticipated withdrawal start date: 3/29/2013

Anticipated withdrawal end date: 3/29/2015

- Endangered Species? Mussel Stream?
- Trout Stream? Tier 3?
- Regulated Stream?
- Proximate PSD?
- Gauged Stream?

Total Volume from Source (gal):

Max. Pump rate (gpm): 1,000
 Max. Simultaneous Trucks: 0
 Max. Truck pump rate (gpm): 0

Reference Gaug: 3114500 MIDDLE ISLAND CREEK AT LITTLE, WV

Drainage Area (sq. mi.): 458.00

Gauge Threshold (cfs): 45

Month	Median monthly flow (cfs)	Threshold (+ pump)	Estimated Available water (cfs)
1	4.30	2.82	1.88
2	5.41	2.82	2.98
3	6.05	2.82	3.63
4	4.49	2.82	2.07
5	2.37	2.82	-0.05
6	0.83	2.82	-1.60
7	0.47	2.82	-1.96
8	0.39	2.82	-2.04
9	0.20	2.82	-2.23
10	0.25	2.82	-2.18
11	1.21	2.82	-1.21
12	2.96	2.82	0.54

Water Availability Profile

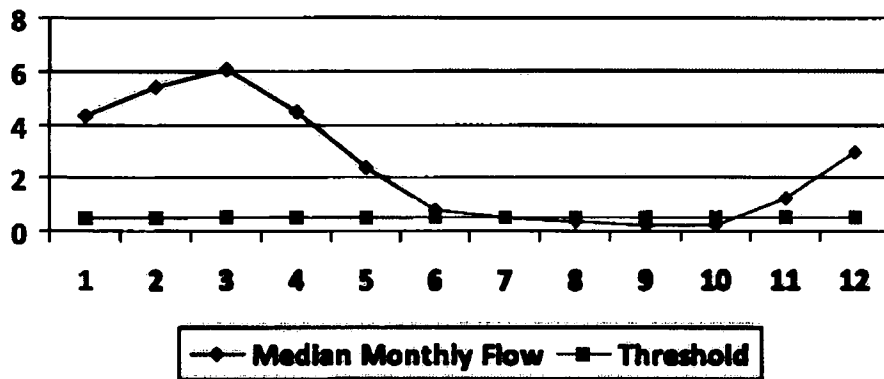

Water Availability Assessment of Location

Base Threshold (cfs): 0.39
 Upstream Demand (cfs): 0.00
 Downstream Demand (cfs): 0.00
 Pump rate (cfs): 2.23
 Headwater Safety (cfs): 0.10
 Ungauged Stream Safety (cfs): 0.10

Min. Gauge Reading (cfs): 69.73
 Passby at Location (cfs): 0.59

"Threshold", as depicted in the chart above is meant only to indicate the calculated base threshold at the proposed withdrawal location. This value does not include the proposed pump rate or existing demand on the stream. Refer to the monthly breakdown above for a more complete estimation of water availability by month.

Source Detail

WMP-01079

API/ID Number: 017-FWC-00001

Operator:

Antero Resources

Hinter Heirs North Centralized Freshwater Impoundment

Source ID: 13828 Source Name: Arnold Creek @ Davis Withdrawal
Jonathon Davis

Source Latitude: 39.302006
Source Longitude: -80.824561

HUC-8 Code: 5030201

Drainage Area (sq. mi.): 20.83 County: Doddridge

Anticipated withdrawal start date: 3/29/2013
Anticipated withdrawal end date: 3/29/2015

- Endangered Species? Mussel Stream?
- Trout Stream? Tier 3?
- Regulated Stream?
- Proximate PSD?
- Gauged Stream?

Total Volume from Source (gal):

Max. Pump rate (gpm): 1,000

Max. Simultaneous Trucks: 0

Max. Truck pump rate (gpm): 0

Reference Gaug 3114500 MIDDLE ISLAND CREEK AT LITTLE, WV

Drainage Area (sq. mi.) 458.00

Gauge Threshold (cfs): 45

Month	<u>Median monthly flow (cfs)</u>	<u>Threshold (+ pump)</u>	<u>Estimated Available water (cfs)</u>
1	22.34	5.30	17.29
2	28.10	5.30	23.05
3	31.44	5.30	26.39
4	23.35	5.30	18.30
5	12.32	5.30	7.26
6	4.30	5.30	-0.75
7	2.43	5.30	-2.62
8	2.00	5.30	-3.05
9	1.03	5.30	-4.03
10	1.29	5.30	-3.76
11	6.30	5.30	1.25
12	15.39	5.30	10.34

Water Availability Profile

Water Availability Assessment of Location

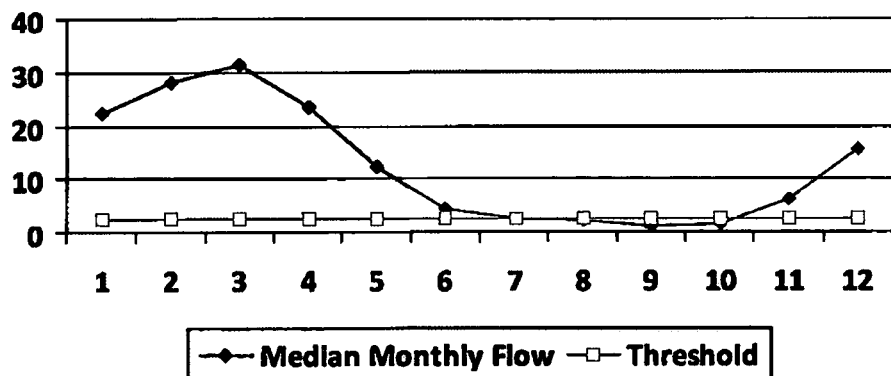

Base Threshold (cfs): 2.05
 Upstream Demand (cfs): 0.00
 Downstream Demand (cfs): 0.00
 Pump rate (cfs): 2.23
 Headwater Safety (cfs): 0.51
 Ungauged Stream Safety (cfs): 0.51

Min. Gauge Reading (cfs): 69.73
 Passby at Location (cfs): 3.07

"Threshold", as depicted in the chart above is meant only to indicate the calculated base threshold at the proposed withdrawal location. This value does not include the proposed pump rate or existing demand on the stream. Refer to the monthly breakdown above for a more complete estimation of water availability by month.

Source Detail

WMP-01079

API/ID Number: 017-FWC-00001

Operator:

Antero Resources

Hinter Heirs North Centralized Freshwater Impoundment

Source ID: 13829 Source Name: Buckeye Creek @ Powell Withdrawal
Dennis Powell

Source Latitude: 39.277142
Source Longitude: -80.690386

HUC-8 Code: 5030201

Drainage Area (sq. mi.): 31.15 County: Doddridge

Anticipated withdrawal start date: 3/29/2013

Anticipated withdrawal end date: 3/29/2015

Total Volume from Source (gal):

Max. Pump rate (gpm): 1,000

Max. Simultaneous Trucks: 0

Max. Truck pump rate (gpm): 0

- Endangered Species? Mussel Stream?
- Trout Stream? Tier 3?
- Regulated Stream?
- Proximate PSD?
- Gauged Stream?

Reference Gaug: 3114500 MIDDLE ISLAND CREEK AT LITTLE, WV

Drainage Area (sq. mi.): 458.00

Gauge Threshold (cfs): 45

Month	<u>Median monthly flow (cfs)</u>	<u>Threshold (+ pump)</u>	<u>Estimated Available water (cfs)</u>
1	33.41	6.82	26.95
2	42.02	6.82	35.56
3	47.02	6.82	40.56
4	34.92	6.82	28.46
5	18.42	6.82	11.96
6	6.43	6.82	-0.03
7	3.64	6.82	-2.82
8	3.00	6.82	-3.46
9	1.53	6.82	-4.92
10	1.93	6.82	-4.53
11	9.42	6.82	2.96
12	23.01	6.82	16.55

Water Availability Profile

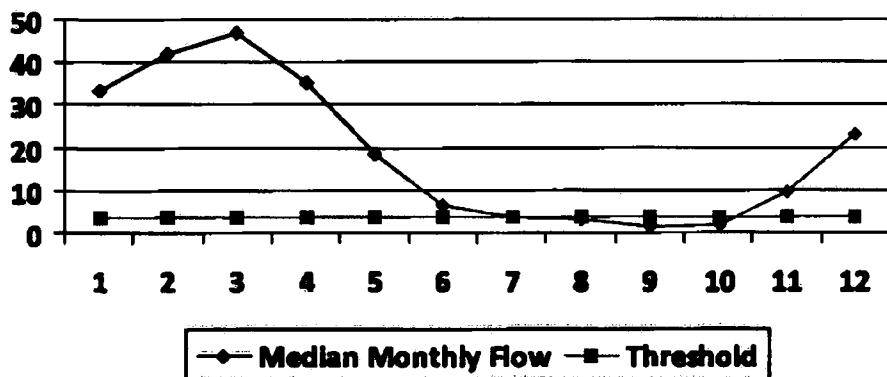

Water Availability Assessment of Location

Base Threshold (cfs):	3.06
Upstream Demand (cfs):	0.00
Downstream Demand (cfs):	0.00
Pump rate (cfs):	2.23
Headwater Safety (cfs):	0.77
Ungauged Stream Safety (cfs):	0.77
<hr/>	
Min. Gauge Reading (cfs):	69.73
Passby at Location (cfs):	4.59

"Threshold", as depicted in the chart above is meant only to indicate the calculated base threshold at the proposed withdrawal location. This value does not include the proposed pump rate or existing demand on the stream. Refer to the monthly breakdown above for a more complete estimation of water availability by month.

Source Detail

WMP-01079

API/ID Number: 017-FWC-00001

Operator:

Antero Resources

Hinter Heirs North Centralized Freshwater Impoundment

Source ID: 13830 Source Name: South Fork of Hughes River @ Knight Withdrawal
Tracy C. Knight & Stephanie C. Knight

Source Latitude: 39.198369
Source Longitude: -80.870969

HUC-8 Code: 5030203

Drainage Area (sq. mi.): 16.26 County: Ritchie

Anticipated withdrawal start date: 3/29/2013
Anticipated withdrawal end date: 3/29/2015

- Endangered Species? Mussel Stream?
- Trout Stream? Tier 3?
- Regulated Stream?
- Proximate PSD?
- Gauged Stream?

Total Volume from Source (gal):

Max. Pump rate (gpm): 3,000
Max. Simultaneous Trucks: 0
Max. Truck pump rate (gpm): 0

Reference Gaug: 3155220 SOUTH FORK HUGHES RIVER BELOW MACFARLAN, WV

Drainage Area (sq. mi.): 229.00 Gauge Threshold (cfs): 22

Month	Median monthly flow (cfs)	Threshold (+ pump)	Estimated Available water (cfs)
1	45.67	14.26	31.44
2	59.55	14.26	45.31
3	65.21	14.26	50.97
4	36.87	14.26	22.63
5	25.86	14.26	11.63
6	13.90	14.26	-0.33
7	6.89	14.26	-7.34
8	3.98	14.26	-10.25
9	4.79	14.26	-9.45
10	5.20	14.26	-9.04
11	15.54	14.26	1.30
12	32.06	14.26	17.82

Water Availability Profile

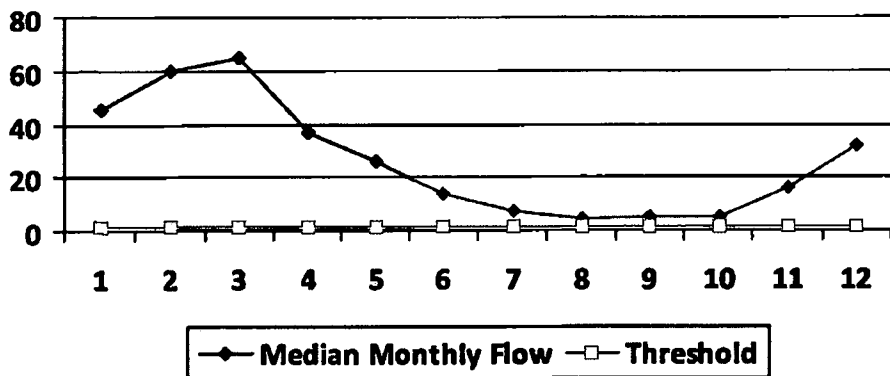

Water Availability Assessment of Location

Base Threshold (cfs): 1.56
 Upstream Demand (cfs): 5.62
 Downstream Demand (cfs): 0.00
 Pump rate (cfs): 6.68
 Headwater Safety (cfs): 0.39
 Ungauged Stream Safety (cfs): 0.00

Min. Gauge Reading (cfs): 39.80
 Passby at Location (cfs): 1.95

"Threshold", as depicted in the chart above is meant only to indicate the calculated base threshold at the proposed withdrawal location. This value does not include the proposed pump rate or existing demand on the stream. Refer to the monthly breakdown above for a more complete estimation of water availability by month.

west virginia department of environmental protection



Water Management Plan: Secondary Water Sources



WMP-01079

API/ID Number: 017-FWC-00001

Operator:

Antero Resources

Hinter Heirs North Centralized Freshwater Impo

Important:

For each proposed secondary water source identified in your water management plan (i.e., groundwater well, lake/reservoir, recycled frac water, multi-site impoundment, out-of-state source), DEP makes no estimation of the availability of water. These sources may prove to be unsuitable water supplies. Please review the following notes:

- For groundwater supply wells, DEP recommends that the operator contact the local health department prior to drilling any new well; and reminds the operator that all drinking water wells within 1,500 feet of a water supply well shall be flow- and quality-tested by the operator at the request of the drinking well owner prior to operation of the water supply well.
- For each proposed multi-site impoundment water source identified in your water management plan (if applicable), DEP will review the withdrawal limits established in the referenced Water Management Plan for current suitability and provide to the operator these limits for each identified intake. Note that withdrawal limits may be modified as necessary based on changing demands upon that water supply.

Lake/Reservoir

Source ID:	13851	Source Name	City of Salem Reservoir (Lower Dog Run)	Source start date:	3/29/2013
			Public Water Provider	Source end date:	3/29/2015
Source Lat:	39.28834	Source Long:	-80.54966	County	Harrison
Max. Daily Purchase (gal)	1,000,000	Total Volume from Source (gal):			

DEP Comments:

APPROVED AFR 0 2 2013

Hinter Heirs North Centralized Freshwater Impot

Important:

For each proposed secondary water source identified in your water management plan (i.e., groundwater well, lake/reservoir, recycled frac water, multi-site impoundment, out-of-state source), DEP makes no estimation of the availability of water. These sources may prove to be unsuitable water supplies. Please review the following notes:

- For groundwater supply wells, DEP recommends that the operator contact the local health department prior to drilling any new well; and reminds the operator that all drinking water wells within 1,500 feet of a water supply well shall be flow- and quality-tested by the operator at the request of the drinking well owner prior to operation of the water supply well.

- For each proposed multi-site impoundment water source identified in your water management plan (if applicable), DEP will review the withdrawal limits established in the referenced Water Management Plan for current suitability and provide to the operator these limits for each identified intake. Note that withdrawal limits may be modified as necessary based on changing demands upon that water supply.

Source ID: 13852	Source Name	Pennsboro Lake		Source start date:	3/29/2013
				Source end date:	3/29/2015
	Source Lat:	39.281689	Source Long:	-80.925526	County
					Ritchie
	Max. Daily Purchase (gal)			Total Volume from Source (gal):	
DEP Comments:					

Source ID: 13853	Source Name	Powers Lake (Wilderness Water Park Dam)		Source start date:	3/29/2013
				Source end date:	3/29/2015
	Source Lat:	39.255752	Source Long:	-80.463262	County
					Harrison
	Max. Daily Purchase (gal)			Total Volume from Source (gal):	
DEP Comments:					

APPROVED APR 0 2 2013

WMP-01079

API/ID Number 017-FWC-00001

Operator:

Antero Resources

Hinters Heirs North Centralized Freshwater Impou

Important:

For each proposed secondary water source identified in your water management plan (i.e., groundwater well, lake/reservoir, recycled frac water, multi-site impoundment, out-of-state source), DEP makes no estimation of the availability of water. These sources may prove to be unsuitable water supplies. Please review the following notes:

- For groundwater supply wells, DEP recommends that the operator contact the local health department prior to drilling any new well; and reminds the operator that all drinking water wells within 1,500 feet of a water supply well shall be flow- and quality-tested by the operator at the request of the drinking well owner prior to operation of the water supply well.

- For each proposed multi-site impoundment water source identified in your water management plan (if applicable), DEP will review the withdrawal limits established in the referenced Water Management Plan for current suitability and provide to the operator these limits for each identified intake. Note that withdrawal limits may be modified as necessary based on changing demands upon that water supply.

Source ID: 13854 Source Name Powers Lake Two

Source start date: 3/29/2013

Source end date: 3/29/2015

Source Lat: 39.247604

Source Long: -80.466642

County

Harrison

Max. Daily Purchase (gal)

Total Volume from Source (gal):

DEP Comments:

APPROVED APR 02 2013

Hinter Heirs North Centralized Freshwater Impot

Important:

For each proposed secondary water source identified in your water management plan (i.e., groundwater well, lake/reservoir, recycled frac water, multi-site impoundment, out-of-state source), DEP makes no estimation of the availability of water. These sources may prove to be unsuitable water supplies. Please review the following notes:

- For groundwater supply wells, DEP recommends that the operator contact the local health department prior to drilling any new well; and reminds the operator that all drinking water wells within 1,500 feet of a water supply well shall be flow- and quality-tested by the operator at the request of the drinking well owner prior to operation of the water supply well.

- For each proposed multi-site impoundment water source identified in your water management plan (if applicable), DEP will review the withdrawal limits established in the referenced Water Management Plan for current suitability and provide to the operator these limits for each identified intake. Note that withdrawal limits may be modified as necessary based on changing demands upon that water supply.

Other

Source ID: 13855	Source Name	Poth Lake (Landowner Pond)		Source start date:	3/29/2013
		Private Owner		Source end date:	3/29/2015
	Source Lat:	39.221306	Source Long:	-80.463028	County
					Harrison
	Max. Daily Purchase (gal)			Total Volume from Source (gal):	
DEP Comments:					

Source ID: 13856	Source Name	Williamson Pond (Landowner Pond)		Source start date:	3/29/2013
				Source end date:	3/29/2015
	Source Lat:	39.19924	Source Long:	-80.886161	County
					Ritchie
	Max. Daily Purchase (gal)			Total Volume from Source (gal):	
DEP Comments:					

WMP 01079

API/ID Number 017-FWC-00001

Operator:

Antero Resources

Hinters Heirs North Centralized Freshwater Impoi

Important:

For each proposed secondary water source identified in your water management plan (i.e., groundwater well, lake/reservoir, recycled frac water, multi-site impoundment, out-of-state source), DEP makes no estimation of the availability of water. These sources may prove to be unsuitable water supplies. Please review the following notes:

- For groundwater supply wells, DEP recommends that the operator contact the local health department prior to drilling any new well; and reminds the operator that all drinking water wells within 1,500 feet of a water supply well shall be flow- and quality-tested by the operator at the request of the drinking well owner prior to operation of the water supply well.

- For each proposed multi-site impoundment water source identified in your water management plan (if applicable), DEP will review the withdrawal limits established in the referenced Water Management Plan for current suitability and provide to the operator these limits for each identified intake. Note that withdrawal limits may be modified as necessary based on changing demands upon that water supply.

Source ID: 13857	Source Name	Eddy Pond (Landowner Pond)	Source start date:	3/29/2013		
			Source end date:	3/29/2015		
	Source Lat:	39.19924	Source Long:	-80.886161	County	Ritchie
	Max. Daily Purchase (gal)		Total Volume from Source (gal):			
	DEP Comments:					

Source ID: 13858	Source Name	Hog Lick Quarry Industrial Facility	Source start date:	3/29/2013		
			Source end date:	3/29/2015		
	Source Lat:	39.419272	Source Long:	-80.217941	County	Marion
	Max. Daily Purchase (gal)	1,000,000	Total Volume from Source (gal):			
	DEP Comments:					

Hinter Heirs North Centralized Freshwater Impo

Important:

For each proposed secondary water source identified in your water management plan (i.e., groundwater well, lake/reservoir, recycled frac water, multi-site impoundment, out-of-state source), DEP makes no estimation of the availability of water. These sources may prove to be unsuitable water supplies. Please review the following notes:

- For groundwater supply wells, DEP recommends that the operator contact the local health department prior to drilling any new well; and reminds the operator that all drinking water wells within 1,500 feet of a water supply well shall be flow- and quality-tested by the operator at the request of the drinking well owner prior to operation of the water supply well.

- For each proposed multi-site impoundment water source identified in your water management plan (if applicable), DEP will review the withdrawal limits established in the referenced Water Management Plan for current suitability and provide to the operator these limits for each identified intake. Note that withdrawal limits may be modified as necessary based on changing demands upon that water supply.

Source ID: 13859	Source Name	Glade Fork Mine Industrial Facility		Source start date:	3/29/2013
				Source end date:	3/29/2015
	Source Lat:	38.965767	Source Long:	-80.299313	County Upshur
	Max. Daily Purchase (gal)	1,000,000	Total Volume from Source (gal):		

DEP Comments:

WMP#: 01079



west virginia department of environmental protection
601 57th Street SE
Charleston, WV 25304-2345

**WATER MANAGEMENT PLAN/
WATER ADDENDUM**
Centralized Impoundments and Pits
Office of Oil and Gas
Phone: (304) 926-0450

DEP Office Use only	
Date Received by Oil & Gas:	
Administratively Complete - Oil & Gas: <input type="checkbox"/> Yes <input type="checkbox"/> No:	
Date Received by Water Use:	
Complete - Water Use: <input checked="" type="checkbox"/> Yes <input type="checkbox"/> No: JH	

Section I - Operator Information

Identifier (assigned by Oil & Gas): ⁰¹⁷~~015~~ **FWC-60001**
 Modification?

Operator Name: Antero Resources Appalachian Corporation	
Operator ID: 49448855	Registered in the Frac Water Reporting Website? Yes <input checked="" type="checkbox"/> No <input type="checkbox"/>
Mailing Address: 1625 17th Street Denver CO 80202	Contact Name/Title (Water Resources Manager): Amanda Femley/Environmental and Regulatory Analyst
Contact Phone: (303) 357- 6736	Contact Email: afemley@anteroresources.com

*If no, the operator will be required to register with the WVDEP Water Use Section; contact dep.water.use@wv.gov

Section II - Impoundment/Pit Overview

Impoundment/Pit Name: Hinte Heirs North Centralized Freshwater Impoundment			
<input checked="" type="checkbox"/> Centralized Impoundment (Freshwater)	Location (decimal degrees, NAD 83)		
	Latitude: 39.18764327	Longitude: -80.70739783	County: Doddridge
<input type="checkbox"/> Centralized Waste Pit	Landowner name and address: David Burton and Vivian Burton 1094 Williamstown Pike, Williamstown, WV. 26187		
Phone:			

Section III - Source Water Overview (check all that apply)

<input checked="" type="checkbox"/> Streams/Rivers	<input checked="" type="checkbox"/> Lakes/Reservoirs/Pond	<input checked="" type="checkbox"/> Ground Water	<input checked="" type="checkbox"/> Purchased Water (PSD)
<input type="checkbox"/> Purchased Water (Private)	<input type="checkbox"/> Recycled Frac Water	Other (describe):	
Total Impoundment/pit capacity (gal): 5,184,722.8			

Received
Office of Oil & Gas
JAN 2 2013

Section III(a) - Surface Water Source (to be completed for each surface water withdrawal location, print additional pages as necessary)

Source Name: West Fork River at JCP Withdrawal		
Location (decimal degrees, NAD 83)		
Latitude: 39.3209139	Longitude: -80.3375722	County: Harrison
Landowner name and address: James & Brenda Raines PO Box 446, Lumberport WV 26386; Clarence Mutschelknaus 107 E. Main St, Salem WV 26426; Patrick Deem, Jr. 623 Rivendell Dr, Bridgeport WV 26330		Phone: James Raines (304) 641- 9594
Obtained Landowner Permission? Yes <input checked="" type="checkbox"/> No <input type="checkbox"/>		

Proposed Withdrawal Details

Start Date:	End Date:	Total Withdrawal from Source (gal):	Max. Pump Rate (gpm): 1000 gpm
No. of Pump Trucks: N/A	Max. Pump Rate per Truck (gpm): N/A	No. Trucks Simultaneously Pumping: N/A	

Determination that sufficient flow is available downstream from proposed intake point

Allow passby to be calculated by the DEP (Preferred)? Yes <input checked="" type="checkbox"/> No <input type="checkbox"/> (If no, advance written authorization by DEP is required. Attach authorization and details.)

Aquatic Life Protection

Describe Entrainment and Impingement Prevention Plan:
Fish screens will be installed on the water withdrawal intake hoses to prevent losses of resident fresh water fish with a minimum fork length of 5 mm (approx. 1 inch). The sizing of the fish screens will also afford protection of mussels. The water withdrawal hoses will be installed a minimum of 300 mm (12 in) above the bottom of the watercourse to prevent entrainment of sediment and aquatic organisms associated with the streambed.

Describe Invasive Species Transfer Prevention Plan:
Water withdrawal trucks and intake hoses will be disinfected on a routine basis. Withdrawal trucks will be blown out at the conclusion of each day. In addition, individual trucking companies will be assigned to a specific withdrawal point to prevent the transfer of aquatic life between surface water sources.

Stream details

DEP Office Use Only			
Contact Recreation <input type="checkbox"/>	Aquatic Life-Trout Water <input type="checkbox"/>	Aquatic Life-Warm Water <input type="checkbox"/>	Drinking Water Supply <input type="checkbox"/>
Industrial <input type="checkbox"/>	Agriculture <input type="checkbox"/>	Irrigation <input type="checkbox"/>	Reference Gauge: <input type="checkbox"/>
Gauged Stream: <input type="checkbox"/>	Stream Final Code: <input type="checkbox"/>	Regulated by: <input type="checkbox"/>	
Trout? <input type="checkbox"/>	Sensitive Aquatic Species? <input type="checkbox"/>	Tier 3 Stream? <input type="checkbox"/>	Within 1 mile upstream of a PSD? Yes <input type="checkbox"/> No <input checked="" type="checkbox"/>
Mussels? <input type="checkbox"/>	Upstream Drainage Area? <input type="checkbox"/>		

Section III(a) - Surface Water Source (to be completed for each surface water withdrawal location, print additional pages as necessary)

Source Name: West Fork River at McDonald			
Location (decimal degrees, NAD 83)			
Latitude: 39.16761	Longitude: 80.45069	County: Harrison	
Landowner name and address: William M McDonald RR2 Box 215A, Jane Iew, WV, 26378		Phone: 304-677-5944	
Obtained Landowner Permission? Yes <input checked="" type="checkbox"/> No <input type="checkbox"/>			

Proposed Withdrawal Details

Start Date:	End Date:	Total Withdrawal from Source (gal):	Max. Pump Rate (gpm): 3000
No. of Pump Trucks: N/A	Max. Pump Rate per Truck (gpm): N/A	No. Trucks Simultaneously Pumping: N/A	

Determination that sufficient flow is available downstream from proposed intake point

Allow passby to be calculated by the DEP (Preferred)? Yes <input checked="" type="checkbox"/> No <input type="checkbox"/> (If no, advance written authorization by DEP is required. Attach authorization and details.)

Aquatic Life Protection

Describe Entrainment and Impingement Prevention Plan: Fish screens will be installed on the water withdrawal intake hoses to prevent losses of resident fresh water fish with a minimum fork length of 5 mm (approx. 1 inch). The sizing of the fish screens will also afford protection of mussels. The water withdrawal hoses will be installed a minimum of 300 mm (12 in) above the bottom of the watercourse to prevent entrainment of sediment and aquatic organisms associated with the streambed.
Describe Invasive Species Transfer Prevention Plan: Water withdrawal trucks and intake hoses will be disinfected on a routine basis. Withdrawal trucks will be blown out at the conclusion of each day. In addition, individual trucking companies will be assigned to a specific withdrawal point to prevent the transfer of aquatic life between the withdrawal locations.

Stream details

DEP Office Use Only			
Contact Recreation <input type="checkbox"/>	Aquatic Life-Trout Water <input type="checkbox"/>	Aquatic Life-Warm Water <input type="checkbox"/>	Drinking Water Supply <input type="checkbox"/>
Industrial <input type="checkbox"/>	Agriculture <input type="checkbox"/>	Irrigation <input type="checkbox"/>	Reference Gauge: <input type="checkbox"/>
Gauged Stream: <input type="checkbox"/>	Stream Final Code:	Regulated by:	
Trout? <input type="checkbox"/>	Sensitive Aquatic Species? <input type="checkbox"/>	Tier 3 Stream? <input type="checkbox"/>	Within 1 mile upstream of PSD? Yes <input type="checkbox"/> No <input type="checkbox"/>
Mussels? <input type="checkbox"/>	Upstream Drainage Area?		

Received
 Office of Oil & Gas
 MAY 24 2013

Section III(a) - Surface Water Source (to be completed for each surface water withdrawal location, print additional pages as necessary)

Source Name: West Fork River at GAL Withdrawal		
Location (decimal degrees, NAD 83)		
Latitude: 39.16422	Longitude: -80.45173	County: Harrison
Landowner name and address: David Shrieves PO Box 215Z Jane Lew WV 26378		Phone: 304-745-3546
Obtained Landowner Permission? Yes <input checked="" type="checkbox"/> No <input type="checkbox"/>		

Proposed Withdrawal Details

Start Date:	End Date:	Total Withdrawal from Source (gal):	Max. Pump Rate (gpm): 1000 gpm
No. of Pump Trucks: N/A	Max. Pump Rate per Truck (gpm): N/A	No. Trucks Simultaneously Pumping: N/A	

Determination that sufficient flow is available downstream from proposed intake point

Allow passby to be calculated by the DEP (Preferred)? Yes <input checked="" type="checkbox"/> No <input type="checkbox"/> (If no, advance written authorization by DEP is required. Attach authorization and details.)

Aquatic Life Protection

Describe Entrainment and Impingement Prevention Plan: Fish screens will be installed on the water withdrawal intake hoses to prevent losses of resident fresh water fish with a minimum fork length of 5 mm (approx. 1 inch). The sizing of the fish screens will also afford protection of mussels. The water withdrawal hoses will be installed a minimum of 300 mm (12 in) above the bottom of the watercourse to prevent entrainment of sediment and aquatic organisms associated with the streambed.
Describe Invasive Species Transfer Prevention Plan: Water withdrawal trucks and intake hoses will be disinfected on a routine basis. Withdrawal trucks will be blown out at the conclusion of each day. In addition, individual trucking companies will be assigned to a specific withdrawal point to prevent the transfer of aquatic life between surface water sources.

Stream details

DEP Office Use Only			
Contact Recreation <input type="checkbox"/>	Aquatic Life-Trout Water <input type="checkbox"/>	Aquatic Life-Warm Water <input type="checkbox"/>	Drinking Water Supply <input type="checkbox"/>
Industrial <input type="checkbox"/>	Agriculture <input type="checkbox"/>	Irrigation <input type="checkbox"/>	Reference Gauge: <input type="checkbox"/>
Gauged Stream: <input type="checkbox"/>	Stream Final Code:	Regulated by:	
Trout? <input type="checkbox"/>	Sensitive Aquatic Species? <input type="checkbox"/>	Tier 3 Stream? <input type="checkbox"/>	Within 1 mile upstream of PSD? Yes <input type="checkbox"/> No <input type="checkbox"/>
Mussels? <input type="checkbox"/>	Upstream Drainage Area? <input type="checkbox"/>		

RECEIVED
 Office of Oil & Gas
 JAN 20 2012

Section III(a) - Surface Water Source (to be completed for each surface water withdrawal location, print additional pages as necessary)

Source Name: McElroy Creek at Forest Withdrawal			
Location (decimal degrees, NAD 83)			
Latitude: 39.39675	Longitude: 80.738197	County: Tyler	
Landowner name and address: Forest C. Moore, Jr. and Brenda L. Moore HC 67 Box 157 West Union, WV 26456		Phone: (304) 758-5127	
Obtained Landowner Permission? Yes <input checked="" type="checkbox"/> No <input type="checkbox"/>			

Proposed Withdrawal Details

Start Date:	End Date:	Total Withdrawal from Source (gal):	Max. Pump Rate (gpm): 1000 gpm
No. of Pump Trucks: N/A	Max. Pump Rate per Truck (gpm): N/A	No. Trucks Simultaneously Pumping: N/A	

Determination that sufficient flow is available downstream from proposed intake point

Allow passby to be calculated by the DEP (Preferred)? Yes <input checked="" type="checkbox"/> No <input type="checkbox"/> (If no, advance written authorization by DEP is required. Attach authorization and details.)

Aquatic Life Protection

<p>Describe Entrainment and Impingement Prevention Plan:</p> <p>Fish screens will be installed on the water withdrawal intake hoses to prevent losses of resident fresh water fish with a minimum fork length of 5 mm (approx. 1 inch). The sizing of the fish screens will also afford protection of mussels. The water withdrawal hoses will be installed a minimum of 300 mm (12 in) above the bottom of the watercourse to prevent entrainment of sediment and aquatic organisms associated with the streambed.</p>
<p>Describe Invasive Species Transfer Prevention Plan:</p> <p>Water withdrawal trucks and intake hoses will be disinfected on a routine basis. Withdrawal trucks will be blown out at the conclusion of each day. In addition, individual trucking companies will be assigned to a specific withdrawal point to prevent the transfer of aquatic life between surface water sources.</p>

Stream details

DEP Office Use Only			
Contact Recreation <input type="checkbox"/>	Aquatic Life-Trout Water <input type="checkbox"/>	Aquatic Life-Warm Water <input type="checkbox"/>	Drinking Water Supply <input type="checkbox"/>
Industrial <input type="checkbox"/>	Agriculture <input type="checkbox"/>	Irrigation <input type="checkbox"/>	Reference Gauge: <input type="checkbox"/>
Gauged Stream: <input checked="" type="checkbox"/>	Stream Final Code:	Regulated by:	
Trout? <input type="checkbox"/>	Sensitive Aquatic Species? <input type="checkbox"/>	Tier 3 Stream? <input type="checkbox"/>	Within 1 mile upstream of a PSD? Yes <input type="checkbox"/> No <input type="checkbox"/>
Mussels? <input type="checkbox"/>	Upstream Drainage Area?		

Received
 Oil & Gas
 1/23/2012

Section III(a) - Surface Water Source (to be completed for each surface water withdrawal location, print additional pages as necessary)

Source Name: McElroy Creek at Sweeney Withdrawal		
Location (decimal degrees, NAD 83)		
Latitude: 39.398123	Longitude: -80.656808	County: Doddridge
Landowner name and address: Bill Sweeney PO Box 126 Mannington, WV 26582		Phone: 304-986-1432
Obtained Landowner Permission? Yes <input checked="" type="checkbox"/> No <input type="checkbox"/>		

Proposed Withdrawal Details

Start Date:	End Date:	Total Withdrawal from Source (gal):	Max. Pump Rate (gpm): 1000 gpm
No. of Pump Trucks: N/A	Max. Pump Rate per Truck (gpm): N/A	No. Trucks Simultaneously Pumping: N/A	

Determination that sufficient flow is available downstream from proposed intake point

Allow passby to be calculated by the DEP (Preferred)? Yes <input checked="" type="checkbox"/> No <input type="checkbox"/> (If no, advance written authorization by DEP is required. Attach authorization and details.)

Aquatic Life Protection

Describe Entrainment and Impingement Prevention Plan:
Fish screens will be installed on the water withdrawal intake hoses to prevent losses of resident fresh water fish with a minimum fork length of 5 mm (approx. 1 inch). The sizing of the fish screens will also afford protection of mussels. The water withdrawal hoses will be installed a minimum of 300 mm (12 in) above the bottom of the watercourse to prevent entrainment of sediment and aquatic organisms associated with the streambed.

Describe Invasive Species Transfer Prevention Plan:
Water withdrawal trucks and intake hoses will be disinfected on a routine basis. Withdrawal trucks will be blown out at the conclusion of each day. In addition, individual trucking companies will be assigned to a specific withdrawal point to prevent the transfer of aquatic life between surface water sources.

Stream details

DEP Office Use Only			
Contact Recreation <input type="checkbox"/>	Aquatic Life-Trout Water <input type="checkbox"/>	Aquatic Life-Warm Water <input type="checkbox"/>	Drinking Water Supply <input type="checkbox"/>
Industrial <input type="checkbox"/>	Agriculture <input type="checkbox"/>	Irrigation <input type="checkbox"/>	Reference Gauge: <input type="checkbox"/>
Gauged Stream: <input type="checkbox"/>	Stream Final Code:	Regulated by:	
Trout? <input type="checkbox"/>	Sensitive Aquatic Species? <input type="checkbox"/>	Tier 3 Stream? <input type="checkbox"/>	Within 1 mile upstream of a 200? Yes <input type="checkbox"/>
Mussels? <input type="checkbox"/>	Upstream Drainage Area?		

Received
 Office of Water & Gas
 JAN 25 2009

Section III(a) - Surface Water Source (to be completed for each surface water withdrawal location, print additional pages as necessary)

Source Name: Meathouse Fork at Gagnon Withdrawal		
Location (decimal degrees, NAD 83)		
Latitude: 39.260540	Longitude: -80.720998	County: Doddridge
Landowner name and address: George L. Gagnon and Susan C. Gagnon Rt.1 Box 312, West Union, West Virginia		Phone: 304-709-4029
Obtained Landowner Permission? Yes <input checked="" type="checkbox"/> No <input type="checkbox"/>		

Proposed Withdrawal Details

Start Date:	End Date:	Total Withdrawal from Source (gal):	Max. Pump Rate (gpm): 1000
No. of Pump Trucks: N/A	Max. Pump Rate per Truck (gpm): N/A	No. Trucks Simultaneously Pumping: N/A	

Determination that sufficient flow is available downstream from proposed intake point

Allow passby to be calculated by the DEP (Preferred)? Yes <input checked="" type="checkbox"/> No <input type="checkbox"/> (If no, advance written authorization by DEP is required. Attach authorization and details.)

Aquatic Life Protection

<p>Describe Entrainment and Impingement Prevention Plan:</p> <p>Fish screens will be installed on the water withdrawal intake hoses to prevent losses of resident fresh water fish with a minimum fork length of 5 mm (approx. 1 inch). The sizing of the fish screens will also afford protection of mussels. The water withdrawal hoses will be installed a minimum of 300 mm (12 in) above the bottom of the watercourse to prevent entrainment of sediment and aquatic organisms associated with the streambed.</p>
<p>Describe Invasive Species Transfer Prevention Plan:</p> <p>Water withdrawal trucks and intake hoses will be disinfected on a routine basis. Withdrawal trucks will be blown out at the conclusion of each day. In addition, individual trucking companies will be assigned to a specific withdrawal point to prevent the transfer of aquatic life between surface water sources.</p>

Stream details

DEP Office Use Only			
Contact Recreation <input type="checkbox"/>	Aquatic Life-Trout Water <input type="checkbox"/>	Aquatic Life-Warm Water <input type="checkbox"/>	Drinking Water Supply <input type="checkbox"/>
Industrial <input type="checkbox"/>	Agriculture <input type="checkbox"/>	Irrigation <input type="checkbox"/>	Reference Gauge: <input type="checkbox"/>
Gauged Stream : <input type="checkbox"/>	Stream Final Code: <input type="checkbox"/>	Regulated by: <input type="checkbox"/>	
Trout? <input type="checkbox"/>	Sensitive Aquatic Species? <input type="checkbox"/>	Tier 3 Stream? <input type="checkbox"/>	Within 1 mile upstream a PSD? Yes <input type="checkbox"/> No <input type="checkbox"/>
Mussels? <input type="checkbox"/>	Upstream Drainage Area? <input type="checkbox"/>		

Received
 Office of Oil & Gas
 JAN 25 2013

Section III(a) - Surface Water Source (to be completed for each surface water withdrawal location, print additional pages as necessary)

Source Name: Meathouse Creek at Whitehair Withdrawal		
Location (decimal degrees, NAD 83)		
Latitude: 39.211317	Longitude: -80.679592	County: Doddridge
Landowner name and address: Elton Whitehair 3108 Meathouse Fork Road New Milton WV 26411		Phone: 304-873-1351
Obtained Landowner Permission? Yes <input checked="" type="checkbox"/> No <input type="checkbox"/>		

Proposed Withdrawal Details

Start Date:	End Date:	Total Withdrawal from Source (gal):	Max. Pump Rate (gpm): 1000
No. of Pump Trucks: N/A	Max. Pump Rate per Truck (gpm): N/A	No. Trucks Simultaneously Pumping: N/A	

Determination that sufficient flow is available downstream from proposed intake point

Allow passby to be calculated by the DEP (Preferred)? Yes <input checked="" type="checkbox"/> No <input type="checkbox"/> (If no, advance written authorization by DEP is required. Attach authorization and details.)

Aquatic Life Protection

<p>Describe Entrainment and Impingement Prevention Plan: Fish screens will be installed on the water withdrawal intake hoses to prevent losses of resident fresh water fish with a minimum fork length of 5 mm (approx. 1 inch). The sizing of the fish screens will also afford protection of mussels. The water withdrawal hoses will be installed a minimum of 300 mm (12 in) above the bottom of the watercourse to prevent entrainment of sediment and aquatic organisms associated with the streambed.</p>
<p>Describe Invasive Species Transfer Prevention Plan: Water withdrawal trucks and intake hoses will be disinfected on a routine basis. Withdrawal trucks will be blown out at the conclusion of each day. In addition, individual trucking companies will be assigned to a specific withdrawal point to prevent the transfer of aquatic life between surface water sources.</p>

Stream details

DEP Office Use Only			
Contact Recreation <input type="checkbox"/>	Aquatic Life-Trout Water <input type="checkbox"/>	Aquatic Life-Warm Water <input type="checkbox"/>	Drinking Water Supply <input type="checkbox"/>
Industrial <input type="checkbox"/>	Agriculture <input type="checkbox"/>	Irrigation <input type="checkbox"/>	Reference Gauge: <input type="checkbox"/>
Gauged Stream : <input type="checkbox"/>	Stream Final Code:	Regulated by:	
Trout? <input type="checkbox"/>	Sensitive Aquatic Species? <input type="checkbox"/>	Tier 3 Stream? <input type="checkbox"/>	Within 1 mile upstream of a OSD? Yes <input type="checkbox"/> No <input type="checkbox"/>
Mussels? <input type="checkbox"/>	Upstream Drainage Area?		

Received
 Office of Oil & Gas
 JAN 25 2018

Section III(a) - Surface Water Source (to be completed for each surface water withdrawal location, print additional pages as necessary)

Source Name: Tom's Fork at Erwin		
Location (decimal degrees, NAD 83)		
Latitude: 39.174306	Longitude: -80.702992	County: Doddridge
Landowner name and address: John F. Erwin and Sandra E. Erwin 12222 WV Rt. 18 South, New Milton, WV 26411		Phone: (304) 873-1885
Obtained Landowner Permission? Yes <input checked="" type="checkbox"/> No <input type="checkbox"/>		

Proposed Withdrawal Details

Start Date:	End Date:	Total Withdrawal from Source (gal):	Max. Pump Rate (gpm): 1000 gpm
No. of Pump Trucks: N/A	Max. Pump Rate per Truck (gpm): N/A	No. Trucks Simultaneously Pumping: N/A	

Determination that sufficient flow is available downstream from proposed intake point

Allow passby to be calculated by the DEP (Preferred)? Yes <input type="checkbox"/> No <input type="checkbox"/>
(If no, advance written authorization by DEP is required. Attach authorization and details.)

Aquatic Life Protection

Describe Entrainment and Impingement Prevention Plan: Fish screens will be installed on the water withdrawal intake hoses to prevent losses of resident fresh water fish with a minimum fork length of 5 mm (approx. 1 inch). The sizing of the fish screens will also afford protection of mussels. The water withdrawal hoses will be installed a minimum of 300 mm (12 in) above the bottom of the watercourse to prevent entrainment of sediment and aquatic organisms associated with the streambed.
Describe Invasive Species Transfer Prevention Plan: Water withdrawal trucks and intake hoses will be disinfected on a routine basis. Withdrawal trucks will be blown out at the conclusion of each day. In addition, individual trucking companies will be assigned to a specific withdrawal point to prevent the transfer of aquatic life between surface water sources.

Stream details

DEP Office Use Only			
Contact Recreation <input type="checkbox"/>	Aquatic Life-Trout Water <input type="checkbox"/>	Aquatic Life-Warm Water <input type="checkbox"/>	Drinking Water Supply <input type="checkbox"/>
Industrial <input type="checkbox"/>	Agriculture <input type="checkbox"/>	Irrigation <input type="checkbox"/>	Reference Gauge: <input type="checkbox"/>
Gauged Stream: <input type="checkbox"/>	Stream Final Code:	Regulated by:	
Trout? <input type="checkbox"/>	Sensitive Aquatic Species? <input type="checkbox"/>	Tier 3 Stream? <input type="checkbox"/>	Within 1 mile upstream of PSD? Yes <input type="checkbox"/> No <input type="checkbox"/>
Mussels? <input type="checkbox"/>	Upstream Drainage Area?		

Received
 Office of Oil & Gas
 JAN 25 2013

Section III(a) - Surface Water Source (to be completed for each surface water withdrawal location, print additional pages as necessary)

Source Name: Arnold Creek at Davis Withdrawal		
Location (decimal degrees, NAD 83)		
Latitude: 39.300625	Longitude: -80.823622	County: Doddridge
Landowner name and address: Jonathan Davis Rt. 1 Box 271 West Union WV 26456		Phone: (304)873-1916
Obtained Landowner Permission? Yes <input checked="" type="checkbox"/> No <input type="checkbox"/>		

Proposed Withdrawal Details

Start Date:	End Date:	Total Withdrawal from Source (gal):	Max. Pump Rate (gpm): 1000 gpm
No. of Pump Trucks: N/A	Max. Pump Rate per Truck (gpm): N/A	No. Trucks Simultaneously Pumping: N/A	

Determination that sufficient flow is available downstream from proposed intake point

Allow passby to be calculated by the DEP (Preferred)? Yes <input checked="" type="checkbox"/> No <input type="checkbox"/> (If no, advance written authorization by DEP is required. Attach authorization and details.)

Aquatic Life Protection

<p>Describe Entrainment and Impingement Prevention Plan: Fish screens will be installed on the water withdrawal intake hoses to prevent losses of resident fresh water fish with a minimum fork length of 5 mm (approx. 1 inch). The sizing of the fish screens will also afford protection of mussels. The water withdrawal hoses will be installed a minimum of 300 mm (12 in) above the bottom of the watercourse to prevent entrainment of sediment and aquatic organisms associated with the streambed.</p>
<p>Describe Invasive Species Transfer Prevention Plan: Water withdrawal trucks and intake hoses will be disinfected on a routine basis. Withdrawal trucks will be blown out at the conclusion of each day. In addition, individual trucking companies will be assigned to a specific withdrawal point to prevent the transfer of aquatic life between the withdrawal locations.</p>

Stream details

DEP Office Use Only			
Contact Recreation <input type="checkbox"/>	Aquatic Life-Trout Water <input type="checkbox"/>	Aquatic Life-Warm Water <input type="checkbox"/>	Drinking Water Supply <input type="checkbox"/>
Industrial <input type="checkbox"/>	Agriculture <input type="checkbox"/>	Irrigation <input type="checkbox"/>	Reference Gauge: <input type="checkbox"/>
Gauged Stream: <input type="checkbox"/>	Stream Final Code:	Regulated by:	
Trout? <input type="checkbox"/>	Sensitive Aquatic Species? <input type="checkbox"/>	Tier 3 Stream? <input type="checkbox"/>	Within 1 mile upstream of PSD? Yes <input type="checkbox"/> No <input type="checkbox"/>
Mussels? <input type="checkbox"/>	Upstream Drainage Area?		

Received
 Office of Chief Engineer
 JAN 25 2013

Section III(a) - Surface Water Source (to be completed for each surface water withdrawal location, print additional pages as necessary)

Source Name: Buckeye Creek at Powell Withdrawal			
Location (decimal degrees, NAD 83)			
Latitude: 39.277142	Longitude: -80.690386	County: Doddridge	
Landowner name and address: Dennis Powell Grant District Doddridge county, WV		Phone:	
Obtained Landowner Permission? Yes <input checked="" type="checkbox"/> No <input type="checkbox"/>			

Proposed Withdrawal Details

Start Date:	End Date:	Total Withdrawal from Source (gal):	Max. Pump Rate (gpm): 1000
No. of Pump Trucks: N/A	Max. Pump Rate per Truck (gpm): N/A	No. Trucks Simultaneously Pumping: N/A	

Determination that sufficient flow is available downstream from proposed intake point

Allow passby to be calculated by the DEP (Preferred)? Yes <input checked="" type="checkbox"/> No <input type="checkbox"/> (If no, advance written authorization by DEP is required. Attach authorization and details.)

Aquatic Life Protection

Describe Entrainment and Impingement Prevention Plan: Fish screens will be installed on the water withdrawal intake hoses to prevent losses of resident fresh water fish with a minimum fork length of 5 mm (approx. 1 inch). The sizing of the fish screens will also afford protection of mussels. The water withdrawal hoses will be installed a minimum of 300 mm (12 in) above the bottom of the watercourse to prevent entrainment of sediment and aquatic organisms associated with the streambed.
Describe Invasive Species Transfer Prevention Plan: Water withdrawal trucks and intake hoses will be disinfected on a routine basis. Withdrawal trucks will be blown out at the conclusion of each day. In addition, individual trucking companies will be assigned to a specific withdrawal point to prevent the transfer of aquatic life between surface water sources.

Stream details

DEP Office Use Only			
Contact Recreation <input type="checkbox"/>	Aquatic Life-Trout Water <input type="checkbox"/>	Aquatic Life-Warm Water <input type="checkbox"/>	Drinking Water Supply <input type="checkbox"/>
Industrial <input type="checkbox"/>	Agriculture <input type="checkbox"/>	Irrigation <input type="checkbox"/>	Reference Gauge:
Gauged Stream <input type="checkbox"/>	Stream Final Code:	Regulated by:	
Trout? <input type="checkbox"/>	Sensitive Aquatic Species? <input type="checkbox"/>	Tier 3 Stream? <input type="checkbox"/>	Within 1 mile upstream of a PSD? Yes <input type="checkbox"/> No <input type="checkbox"/>
Mussels? <input type="checkbox"/>	Upstream Drainage Area?		

Received
 Office of Air & Gas
 JAN 20 2019

Section III(a) - Surface Water Source (to be completed for each surface water withdrawal location, print additional pages as necessary)

Source Name: South Fork at Knight Withdrawal		
Location (decimal degrees, NAD 83)		
Latitude: 39.198369	Longitude: -80.870969	County: Ritchie
Landowner name and address: Tracy C. Knight and Stephanie C. Knight P.O. Box 138 Pullman, WV 26421		Phone: 303-349-2121
Obtained Landowner Permission? Yes <input checked="" type="checkbox"/> No <input type="checkbox"/>		

Proposed Withdrawal Details

Start Date:	End Date:	Total Withdrawal from Source (gal):	Max. Pump Rate (gpm): 3000 gpm
No. of Pump Trucks: N/A	Max. Pump Rate per Truck (gpm): N/A	No. Trucks Simultaneously Pumping: N/A	

Determination that sufficient flow is available downstream from proposed intake point

Allow passby to be calculated by the DEP (Preferred)? Yes <input checked="" type="checkbox"/> No <input type="checkbox"/> (If no, advance written authorization by DEP is required. Attach authorization and details.)

Aquatic Life Protection

<p>Describe Entrainment and Impingement Prevention Plan: Fish screens will be installed on the water withdrawal intake hoses to prevent losses of resident fresh water fish with a minimum fork length of 5 mm (approx. 1 inch). The sizing of the fish screens will also afford protection of mussels. The water withdrawal hoses will be installed a minimum of 300 mm (12 in) above the bottom of the watercourse to prevent entrainment of sediment and aquatic organisms associated with the streambed.</p>
<p>Describe Invasive Species Transfer Prevention Plan: Water withdrawal trucks and intake hoses will be disinfected on a routine basis. Withdrawal trucks will be blown out at the conclusion of each day. In addition, individual trucking companies will be assigned to a specific withdrawal point to prevent the transfer of aquatic life between the withdrawal locations.</p>

Stream details

DEP Office Use Only			
Contact Recreation <input type="checkbox"/>	Aquatic Life-Trout Water <input type="checkbox"/>	Aquatic Life-Warm Water <input type="checkbox"/>	Drinking Water Supply <input type="checkbox"/>
Industrial <input type="checkbox"/>	Agriculture <input type="checkbox"/>	Irrigation <input type="checkbox"/>	Reference Gauge: <input type="checkbox"/>
Gauged Stream: <input type="checkbox"/>	Stream Final Code:	Regulated by:	
Trout? <input type="checkbox"/>	Sensitive Aquatic Species? <input type="checkbox"/>	Tier 3 Stream? <input type="checkbox"/>	Within 1 mile upstream of PSD? Yes <input type="checkbox"/> No <input type="checkbox"/>
Mussels? <input type="checkbox"/>	Upstream Drainage Area?		

Received
 Office of Oil & Gas
 JAN 25 2013

Section III(a) - Surface Water Source (to be completed for each surface water withdrawal location, print additional pages as necessary)

Source Name: North Fork Hughes at Davis Withdrawal		
Location (decimal degrees, NAD 83)		
Latitude: 39.322363	Longitude: -80.936771	County: Ritchie
Landowner name and address: Lewis P. Davis and Norma J. Davis 4146 Mountain Dr., Pensboro, WV 26415		Phone: 304-659-2249
Obtained Landowner Permission? Yes <input checked="" type="checkbox"/> No <input type="checkbox"/>		

Proposed Withdrawal Details

Start Date:	End Date:	Total Withdrawal from Source (gal):	Max. Pump Rate (gpm): 1000
No. of Pump Trucks: N/A	Max. Pump Rate per Truck (gpm): N/A	No. Trucks Simultaneously Pumping: N/A	

Determination that sufficient flow is available downstream from proposed intake point

Allow passby to be calculated by the DEP (Preferred)? Yes <input type="checkbox"/> No <input type="checkbox"/>
(If no, advance written authorization by DEP is required. Attach authorization and details.)

Aquatic Life Protection

Describe Entrainment and Impingement Prevention Plan: Fish screens will be installed on the water withdrawal intake hoses to prevent losses of resident fresh water fish with a minimum fork length of 5 mm (approx. 1 inch). The sizing of the fish screens will also afford protection of mussels. The water withdrawal hoses will be installed a minimum of 300 mm (12 in) above the bottom of the watercourse to prevent entrainment of sediment and aquatic organisms associated with the streambed.
Describe Invasive Species Transfer Prevention Plan: Water withdrawal trucks and intake hoses will be disinfected on a routine basis. Withdrawal trucks will be blown out at the conclusion of each day. In addition, individual trucking companies will be assigned to a specific withdrawal point to prevent the transfer of aquatic life between surface water sources.

Stream details

DEP Office Use Only			
Contact Recreation <input type="checkbox"/>	Aquatic Life-Trout Water <input type="checkbox"/>	Aquatic Life-Warm Water <input type="checkbox"/>	Drinking Water Supply <input type="checkbox"/>
Industrial <input type="checkbox"/>	Agriculture <input type="checkbox"/>	Irrigation <input type="checkbox"/>	Reference Gauge: <input type="checkbox"/>
Gauged Stream: <input type="checkbox"/>	Stream Final Code:	Regulated by:	
Trout? <input type="checkbox"/>	Sensitive Aquatic Species? <input type="checkbox"/>	Tier 3 Stream? <input type="checkbox"/>	Within 1 mile upstream of PSD? Yes <input type="checkbox"/> No <input type="checkbox"/>
Mussels? <input type="checkbox"/>	Upstream Drainage Area?		

Received
 Office of Oil & Gas
 JAN 25 2018

Section III(a) - Surface Water Source (to be completed for each surface water withdrawal location, print additional pages as necessary)

Source Name: Middle Island Creek at Dawson Withdrawal		
Location (decimal degrees, NAD 83)		
Latitude: 39.379292	Longitude: -80.867803	County: Tyler
Landowner name and address: Gary D Dawson and Rella A Dawson HC 69, Box 31A, Alma, West Virginia, 26320		Phone: (304)-758-0160
Obtained Landowner Permission? Yes <input checked="" type="checkbox"/> No <input type="checkbox"/>		

Proposed Withdrawal Details

Start Date:	End Date:	Total Withdrawal from Source (gal):	Max. Pump Rate (gpm): 3000
No. of Pump Trucks: N/A	Max. Pump Rate per Truck (gpm): N/A	No. Trucks Simultaneously Pumping: N/A	

Determination that sufficient flow is available downstream from proposed intake point

Allow passby to be calculated by the DEP (Preferred)? Yes <input checked="" type="checkbox"/> No <input type="checkbox"/> (If no, advance written authorization by DEP is required. Attach authorization and details.)

Aquatic Life Protection

Describe Entrainment and Impingement Prevention Plan:
Fish screens will be installed on the water withdrawal intake hoses to prevent losses of resident fresh water fish with a minimum fork length of 5 mm (approx. 1 inch). The sizing of the fish screens will also afford protection of mussels. The water withdrawal hoses will be installed a minimum of 300 mm (12 in) above the bottom of the watercourse to prevent entrainment of sediment and aquatic organisms associated with the streambed.

Describe Invasive Species Transfer Prevention Plan:
Water withdrawal trucks and intake hoses will be disinfected on a routine basis. Withdrawal trucks will be blown out at the conclusion of each day. In addition, individual trucking companies will be assigned to a specific withdrawal point to prevent the transfer of aquatic life between surface water sources.

Stream details

DEP Office Use Only			
Contact Recreation <input type="checkbox"/>	Aquatic Life-Trout Water <input type="checkbox"/>	Aquatic Life-Warm Water <input type="checkbox"/>	Drinking Water Supply <input type="checkbox"/>
Industrial <input type="checkbox"/>	Agriculture <input type="checkbox"/>	Irrigation <input type="checkbox"/>	Reference Gauge:
Gauged Stream: <input type="checkbox"/>	Stream Final Code:	Regulated by:	
Trout? <input type="checkbox"/>	Sensitive Aquatic Species? <input type="checkbox"/>	Tier 3 Stream? <input type="checkbox"/>	Within 1 mile upstream of a Pond Yes <input type="checkbox"/> No <input type="checkbox"/>
Mussels? <input type="checkbox"/>	Upstream Drainage Area?		

Received
 Office of Chief Gage
 JAN 25 2013

Section III(b) - Ground Water Source (to be completed for each groundwater withdrawal location, print additional pages as necessary)

Well Permit # (if applicable):		Well name:	
Location (decimal degrees, NAD 83)			
Latitude:	Longitude:	County:	
Aquifer: (if known)			
Landowner name and address:		Phone:	
Obtained Landowner Permission?	<input type="checkbox"/> *New well (Drill date: _____) <input type="checkbox"/> Existing well		
Yes <input type="checkbox"/>	No <input type="checkbox"/>		

*If drilling a new well, please submit well logs to DEP's Water Use Section; Wells must be drilled and plugged in accordance with DHHR regulations

Total Depth:	Type of Casing:	Casing Diameter:	Screen Interval:	Screen Size:
Static Water Elevation:	Top of Casing Elevation:	Surface Elevation:	Type of Well Cap:	
Withdrawal Details				Max. Pump Rate (gpm):

Analysis of potential groundwater impacts

Static Water Level Prior to Test: _____ feet below grade
Drawdown (Water Level/Elevation During Pump Test): _____ feet
Duration of Pump Test: _____ hours
Gallons Per Minute During Pump Test: _____ gpm
Time to Return to Static Water Level After Pump Test: _____ hours

Received
 Office of Oil & Gas
 JAN 25 2013

Section III(c) - Purchased Water Source (to be completed for each water supplier, print additional pages as necessary)

Supplier Name and Contact Information: Sun Valley Withdrawal Jeff Sperry, 234 Power Road Salem, WV, 26426			
Location (decimal degrees, NAD 83)			
Latitude: 39.290626	Longitude: -80.518586	County: Harrison	
Public Water Provider <input checked="" type="checkbox"/>	Waste Water Treatment Plant <input type="checkbox"/>	Industrial (intake locations must be provided) <input type="checkbox"/>	
Commercial Supplier (intake locations must be provided) <input type="checkbox"/>		Private (intake locations must be provided) <input type="checkbox"/>	
Purchase Details			
Start Date:	End Date:	Total Purchase from Source (gal):	Max. daily purchase (gal): 200,000
Supplier intake details:			

Section III(d) - Lake/Reservoir Water Source (to be completed for each lake/reservoir)

Lake/Reservoir Name:			
Location (decimal degrees, NAD 83)			
Latitude:	Longitude	County:	
Landowner name and address:			
Permission to withdraw obtained from owner: Yes <input type="checkbox"/> No <input type="checkbox"/>		Minimum release (cfs):	
Withdrawal Details			
Start Date:	End Date:	Total Withdrawal from Source (gal):	Max. Pump Rate (gpm):

Section III(c) - Purchased Water Source (to be completed for each water supplier, print additional pages as necessary)

Supplier Name and Contact Information: The City of Salem 229 West Main Street Salem WV 26428			
Location(decimal degrees, NAD 83)			
Latitude: 39.28593	Longitude: -80.54605	County: Harrison	
Public Water Provider <input checked="" type="checkbox"/>	Waste Water Treatment Plant <input type="checkbox"/>	Industrial (intake locations must be provided) <input type="checkbox"/>	
Commercial Supplier (intake locations must be provided) <input type="checkbox"/>		Private (intake locations must be provided) <input type="checkbox"/>	
Purchase Details			
Start Date:	End Date:	Total Purchase from Source (gal):	Max. daily purchase (gal): 1000000
Supplier intake details:			

Section III(d) - Lake/Reservoir Water Source (to be completed for each lake/reservoir)

Lake/Reservoir Name: Poth Lake			
Location (decimal degrees, NAD 83)			
Latitude: 39.21945	Longitude -80.886161	County: Harrison	
Landowner name and address: Kevin J. Poth, RR1 Box 199, Lost Creek, West Virginia 26385-9742			
Permission to withdraw obtained from owner: Yes <input checked="" type="checkbox"/> No <input type="checkbox"/>		Minimum release (cfs): N/A	
Withdrawal Details			
Start Date:	End Date:	Total Withdrawal from Source (gal):	Max. Pump Rate (gpm): 1000

Received
 Office of Oil & Gas
 JAN 25 2013

Section III(c) - Purchased Water Source (to be completed for each water supplier, print additional pages as necessary)

Supplier Name and Contact Information:			
Location(decimal degrees, NAD 83)			
Latitude:	Longitude:	County:	
Public Water Provider <input type="checkbox"/>	Waste Water Treatment Plant <input type="checkbox"/>	Industrial (intake locations must be provided) <input type="checkbox"/>	
Commercial Supplier (intake locations must be provided) <input type="checkbox"/>		Private (intake locations must be provided) <input type="checkbox"/>	
Purchase Details			
Start Date:	End Date:	Total Purchase from Source (gal):	Max. daily purchase (gal):
Supplier intake details:			

Section III(d) - Lake/Reservoir Water Source (to be completed for each lake/reservoir)

Lake/Reservoir Name: City of Pennsboro Lake			
Location (decimal degrees, NAD 83)			
Latitude: 39.28347	Longitude: -80.92477	County: Ritchie	
Landowner name and address: Nancy J. 422 Main Street Pennsboro, WV 26415			
Permission to withdraw obtained from owner: Yes <input checked="" type="checkbox"/> No <input type="checkbox"/>		Minimum release (cfs): N/A	
Withdrawal Details			
Start Date:	End Date:	Total Withdrawal from Source (gal):	Max. Pump Rate (gpm): 1000

Received
 Office of Oil & Gas
 JAN 25 2013

Section III(c) - Purchased Water Source (to be completed for each water supplier, print additional pages as necessary)

Supplier Name and Contact Information:			
Location(decimal degrees, NAD 83)			
Latitude:	Longitude:	County:	
Public Water Provider <input type="checkbox"/>	Waste Water Treatment Plant <input type="checkbox"/>	Industrial (intake locations must be provided) <input type="checkbox"/>	
Commercial Supplier (intake locations must be provided) <input type="checkbox"/>		Private (intake locations must be provided) <input type="checkbox"/>	
Purchase Details			
Start Date:	End Date:	Total Purchase from Source (gal):	Max. daily purchase (gal):
Supplier intake details:			

Section III(d) - Lake/Reservoir Water Source (to be completed for each lake/reservoir)

Lake/Reservoir Name: Powers Lake			
Location (decimal degrees, NAD 83)			
Latitude: 39.25575	Longitude: -80.463262	County: Harrison	
Landowner name and address: Nancy J. Powers RR-4 Box 854 Salem West Virginia 26426-8915			
Permission to withdraw obtained from owner: Yes <input checked="" type="checkbox"/> No <input type="checkbox"/>		Minimum release (cfs): N/A	
Withdrawal Details			
Start Date:	End Date:	Total Withdrawal from Source (gal):	Max. Pumped Rate (gpm): 1000

Received
 Office of Oil & Gas
 JAN 25 2013

Section III(c) - Purchased Water Source (to be completed for each water supplier, print additional pages as necessary)

Supplier Name and Contact Information:			
Location(decimal degrees, NAD 83)			
Latitude:	Longitude:	County:	
Public Water Provider <input type="checkbox"/>	Waste Water Treatment Plant <input type="checkbox"/>	Industrial (intake locations must be provided) <input type="checkbox"/>	
Commercial Supplier (intake locations must be provided) <input type="checkbox"/>		Private (intake locations must be provided) <input type="checkbox"/>	
Purchase Details			
Start Date:	End Date:	Total Purchase from Source (gal):	Max. daily purchase (gal):
Supplier intake details:			

Section III(d) - Lake/Reservoir Water Source (to be completed for each lake/reservoir)

Lake/Reservoir Name: Powers Lake Two		
Location (decimal degrees, NAD 83)		
Latitude: 39.2476045	Longitude -80.4666424	County: Harrison
Landowner name and address: Nancy J. Powers RR-4 Box 854 Salem West Virginia 26426-8915		
Permission to withdraw obtained from owner: Yes <input checked="" type="checkbox"/> No <input type="checkbox"/>	Minimum release (cfs): N/A	
Withdrawal Details		
Start Date:	End Date:	Total Withdrawal from Source (gal):
		Max. Pumping Rate (gpm): 1000

Received
 Office of Oil & Gas
 JAN 25 2013

Section III(c) - Purchased Water Source (to be completed for each water supplier, print additional pages as necessary)

Supplier Name and Contact Information:			
Location(decimal degrees, NAD 83)			
Latitude:	Longitude:	County:	
Public Water Provider <input type="checkbox"/>	Waste Water Treatment Plant <input type="checkbox"/>	Industrial (intake locations must be provided) <input type="checkbox"/>	
Commercial Supplier (intake locations must be provided) <input type="checkbox"/>	Private (intake locations must be provided) <input type="checkbox"/>		
Purchase Details			
Start Date:	End Date:	Total Purchase from Source (gal):	Max. daily purchase (gal):
Supplier intake details:			

Section III(d) - Lake/Reservoir Water Source (to be completed for each lake/reservoir)

Lake/Reservoir Name: Williamson Pond			
Location (decimal degrees, NAD 83)			
Latitude:	Longitude	County:	
39.199379	-80.884347	Ritchie	
Landowner name and address:			
Andrew and Yolanda Williamson 783 4-Mile Creek Road Branchland, WV 25506			
Permission to withdraw obtained from owner: Yes <input checked="" type="checkbox"/> No <input type="checkbox"/>		Minimum release (cfs): N/A	
Withdrawal Details			
Start Date:	End Date:	Total Withdrawal from Source (gal):	Max. Pumping Rate (gpm):
			1000

Received
Office of Air & Gas
JAN 2 2014

Section III(c) - Purchased Water Source (to be completed for each water supplier, print additional pages as necessary)

Supplier Name and Contact Information:			
Location(decimal degrees, NAD 83)			
Latitude:	Longitude:	County:	
Public Water Provider <input type="checkbox"/>	Waste Water Treatment Plant <input type="checkbox"/>	Industrial (intake locations must be provided) <input type="checkbox"/>	
Commercial Supplier (intake locations must be provided) <input type="checkbox"/>		Private (intake locations must be provided) <input type="checkbox"/>	
Purchase Details			
Start Date:	End Date:	Total Purchase from Source (gal):	Max. daily purchase (gal):
Supplier intake details:			

Section III(d) - Lake/Reservoir Water Source (to be completed for each lake/reservoir)

Lake/Reservoir Name: Eddy Pad Pond			
Location (decimal degrees, NAD 83)			
Latitude: 39.3352604	Longitude: -80.9275531	County: Ritchie	
Landowner name and address: Annie B Haymond 4884 Mountain Dr, Pensboro, WV 26415			
Permission to withdraw obtained from owner: Yes <input checked="" type="checkbox"/> No <input type="checkbox"/>		Minimum release (cfs): N/A	
Withdrawal Details			
Start Date:	End Date:	Total Withdrawal from Source (gal):	Max. Pump Rate (gpm): 1000

Received
 Office of Water Use
 JAN 2 2013

Section III(c) - Purchased Water Source (to be completed for each water supplier, print additional pages as necessary)

Supplier Name and Contact Information: Hog Lick Quarry Arthur J. Rockwell PO Box 970 Bridgeport, WV 26330			
Location(decimal degrees, NAD 83)			
Latitude: 39.4192725	Longitude: -80.2179413	County: Marion County	
Public Water Provider <input type="checkbox"/>	Waste Water Treatment Plant <input type="checkbox"/>	Industrial (intake locations must be provided) <input type="checkbox"/>	
Commercial Supplier (intake locations must be provided) <input type="checkbox"/>		Private (intake locations must be provided) <input checked="" type="checkbox"/>	
Purchase Details			
Start Date:	End Date:	Total Purchase from Source (gal):	Max. daily purchase (gal): 1000000
Supplier intake details:			

Section III(d) - Lake/Reservoir Water Source (to be completed for each lake/reservoir)

Lake/Reservoir Name:			
Location (decimal degrees, NAD 83)			
Latitude:	Longitude	County:	
Landowner name and address:			
Permission to withdraw obtained from owner: Yes <input type="checkbox"/> No <input type="checkbox"/>		Minimum release (cfs):	
Withdrawal Details			
Start Date:	End Date:	Total Withdrawal from Source (gal):	Max. Pump Rate (gpm):

Received
 Office of Oil & Gas
 JAN 2 2013

Section III(c) - Purchased Water Source (to be completed for each water supplier, print additional pages as necessary)

Supplier Name and Contact Information: Glade Fork Mine Larry Alderman Rt. 3 Box 312-3 Buckannon, WV 26201			
Location(decimal degrees, NAD 83)			
Latitude: 38.9657673	Longitude: -80.2993132	County: Upshur	
Public Water Provider <input type="checkbox"/>	Waste Water Treatment Plant <input type="checkbox"/>	Industrial (intake locations must be provided) <input type="checkbox"/>	
Commercial Supplier (intake locations must be provided) <input type="checkbox"/>		Private (intake locations must be provided) <input checked="" type="checkbox"/>	
Purchase Details			
Start Date:	End Date:	Total Purchase from Source (gal):	Max. daily purchase (gal): 1000000
Supplier intake details:			

Section III(d) - Lake/Reservoir Water Source (to be completed for each lake/reservoir)

Lake/Reservoir Name:			
Location (decimal degrees, NAD 83)			
Latitude:	Longitude	County:	
Landowner name and address:			
Permission to withdraw obtained from owner: Yes <input type="checkbox"/> No <input type="checkbox"/>		Minimum release (cfs):	
Withdrawal Details			
Start Date:	End Date:	Total Withdrawal from Source (gal):	Max. Pump Rate (gpm):

Received
 Office of Oil & Gas
 JAN 2 2013

Section III(c) - Purchased Water Source (to be completed for each water supplier, print additional pages as necessary)

Supplier Name and Contact Information: Mr. Clifford E. Smith Solo Construction, LLC PO Box 544 St. Marys, WV 26170			
Location(decimal degrees, NAD 83)			
Latitude: 39.399094	Longitude: -81.185548	County: Pleasants	
Public Water Provider <input type="checkbox"/>	Waste Water Treatment Plant <input type="checkbox"/>	Industrial (intake locations must be provided) <input checked="" type="checkbox"/>	
Commercial Supplier (intake locations must be provided) <input type="checkbox"/>		Private (intake locations must be provided) <input type="checkbox"/>	
Purchase Details			
Start Date:	End Date:	Total Purchase from Source (gal):	Max. daily purchase (gal): 1000000
Supplier intake details: Middle Island Creek - 39.399094 -81.185548			

Section III(d) - Lake/Reservoir Water Source (to be completed for each lake/reservoir)

Lake/Reservoir Name:			
Location (decimal degrees, NAD 83)			
Latitude:	Longitude	County:	
Landowner name and address:			
Permission to withdraw obtained from owner: Yes <input type="checkbox"/> No <input type="checkbox"/>		Minimum release (cfs):	
Withdrawal Details			
Start Date:	End Date:	Total Withdrawal from Source (gal):	Max. Pump Rate (gpm):

Received
 Office of Oil & Gas
 JAN 2 2013

Section III(f) - Recycled Frac Water (to be completed for each source, print additional pages as necessary)

API # of Previous Well (or other descriptor):	Total volume from source (gal):
Date of Water Transfer	
Start Date:	End Date:

API # of Previous Well (or other descriptor):	Total volume from source (gal):
Date of Water Transfer	
Start Date:	End Date:

API # of Previous Well (or other descriptor):	Total volume from source (gal):
Date of Water Transfer	
Start Date:	End Date:

API # of Previous Well (or other descriptor):	Total volume from source (gal):
Date of Water Transfer	
Start Date:	End Date:

API # of Previous Well (or other descriptor):	Total volume from source (gal):
Date of Water Transfer	
Start Date:	End Date:

Received
 Office of Oil & Gas
 JAN 24 2013

Section VI - Operator Comments

--

Section VII - Plan Reviewed By

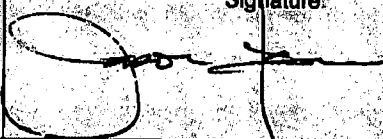
DEP Office Use only		
API # 017-PWC-00001		
Name: Jason Harman	Signature: 	Date: 3/28/13
Comments		

Received
Office of Oil & Gas
JAN 2 2013

MAINTENANCE, MONITORING, AND
EMERGENCY ACTION PLAN
HINTER HEIRS NORTH CENTRALIZED
FRESHWATER IMPOUNDMENT

ID# _____

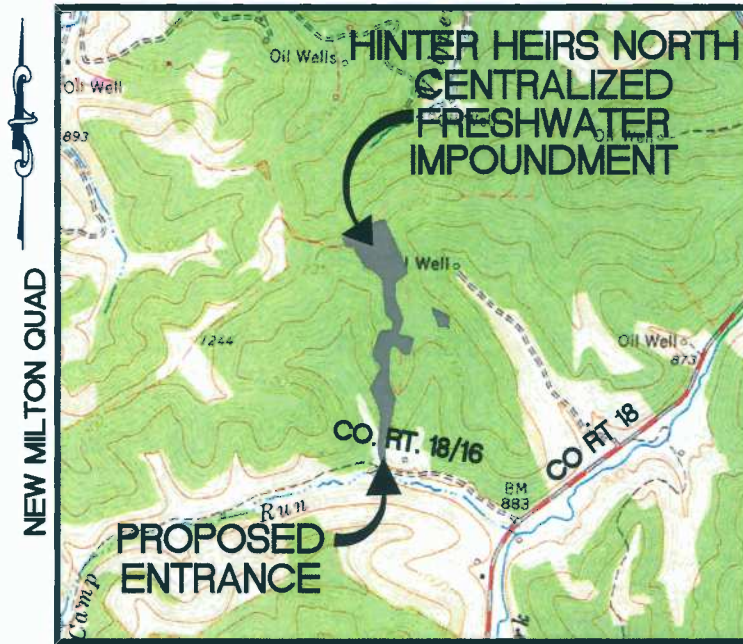

VICINITY MAP

1" = 2,000'



151 Windy Hill Lane
Winchester, VA 22602
Telephone: (888) 662-4185
www.navituseng.com

Prepared For:

Engineering ◀ Survey ◀ Environmental ◀ GIS



981 East Washington Avenue
Ellenboro, WV 26346
(304) 869-3405

Contacts:

Aaron Kunzler, Construction Supervisor
(405) 227-8344
Anthony Smith, Field Engineer
(304) 673-6196
Jack Bell, Land Agent
(304) 376-9682
Chris Brown, Water Resources
(304) 877-8233

Designed By:
Navitus Engineering Inc.

Project Manager:
Cyrus Kump, PE
ckump@navituseng.com

Surface Owner (s)
Carl Hinter Heirs

Tax Parcel:
Map 15 Parcel 12

Location:
New Milton District, Doddridge County
West Virginia



Revised: May 31, 2013
Date: January 21, 2013

FN# ANT028

TABLE OF CONTENTS

INTRODUCTION.....	2
Road Map.....	3
Site Plan.....	4
PART I - MONITORING PLAN AND INSPECTION SCHEDULE.....	5
Section A – Normal Conditions:.....	5
Section B – Dangerous Conditions:.....	6
Section C – Standby Alert:	7
PART II- EMERGENCY ACTION AND EVACUATION PLAN.....	9
Section A - Notification of Agencies:.....	9
PART III- POST EVACUATION/ROAD CLOSURE PLAN.....	10
Section A - Should No Failure Occur:.....	10
PART IV - ADMINISTRATION AND RECORD KEEPING	11
Section A - Distribution:.....	11
Section B – Maintenance Plan:	Error! Bookmark not defined.
Section C – Inspection Record.....	13
PART V – HAZARD EVALUATION AND BREACH CALCULATIONS	14
Section A - Introduction	14
A.1. Background.....	14
Section B - Hydrologic and Hydraulic Analysis	16
B.1. General	16
B.2. Base Map.....	16
B.3. Hydrologic Analysis	16
B.4. Hydraulic Analysis	17
B.5. Results	18
Section C - Results.....	19
C.1. 100 year/24 hour Design Storm Routing	19
C.2. 100 year/24 hour Design Storm Routing with Breach	19
C.3. Summary of Results	19
C.4. Reach Length Analysis	19
PART VI – EVACUATION PLAN AND PROCEDURES.....	20
Section A – Evacuation Plan	20
Section B – Road Closure Procedures	20
APPENDICES	21
Appendix A - Site Maps	21
Appendix B - Residence and Neighboring Property Survey	22
Appendix C- Road Closure and Detour Plans	23

INTRODUCTION

Purpose of Plan:

The purpose of this document is to provide for monitoring of the Hinter Heirs North Centralized Freshwater Impoundment under various conditions so that an emergency situation at the impoundment will be observed promptly and reported to agencies and persons who may be affected. This document also provides a plan for the orderly notification and evacuation of downstream residents to a place of safety in the event of a potential or actual impoundment failure.

Brief Overview of Impoundment:

The Hinter Heirs North Centralized Freshwater Impoundment is an earthen structure on a ridge adjacent to Carder Camp Run. The centralized freshwater impoundment has a maximum exterior embankment height of 38.0 feet and impounds a maximum water volume of 15.91 acre-feet with 1.82 acre-feet being contained within the incised portion of the impoundment (non-incised available water storage volume to embankment top is 14.09 acre-feet). The impoundment was designed by a WV registered professional engineer and its construction shall be certified by a West Virginia registered professional engineer prior to filling. The impoundment will be constructed with an impervious 60 mil. HDPE geo-membrane and a 16 oz. non-woven geotextile layer. The impoundment will be filled using a waterline pumping freshwater from various sources per the approved Water Management Plan (WMP). The inflow and outflow of water will be controlled by portable pumps to maintain a normal freeboard of 2 feet.

Impoundment Location:

The Hinter Heirs North Centralized Freshwater Impoundment is located on a ridge north of the intersection of WV Rt. 18 and Co. Rt. 18/16 (Carder Camp Road). The access road for the site is approximately 0.31 miles northwest of the intersection along Carder Camp Road. The site is adjacent to Carder Camp Run and is located south of New Milton in the Central District of Doddridge County, WV. The impoundment is approximately 2,200 feet from Co. Rt. 18/16 (Carder Camp Road) on a private access road.

How to Use This Document:

Persons using this plan will find a sequence of actions to be taken depending on rainfall and site conditions. A summary of where to find specific monitoring, reporting, and evacuation requirements can be found on the Table of Contents (See Previous Page).

Road Map

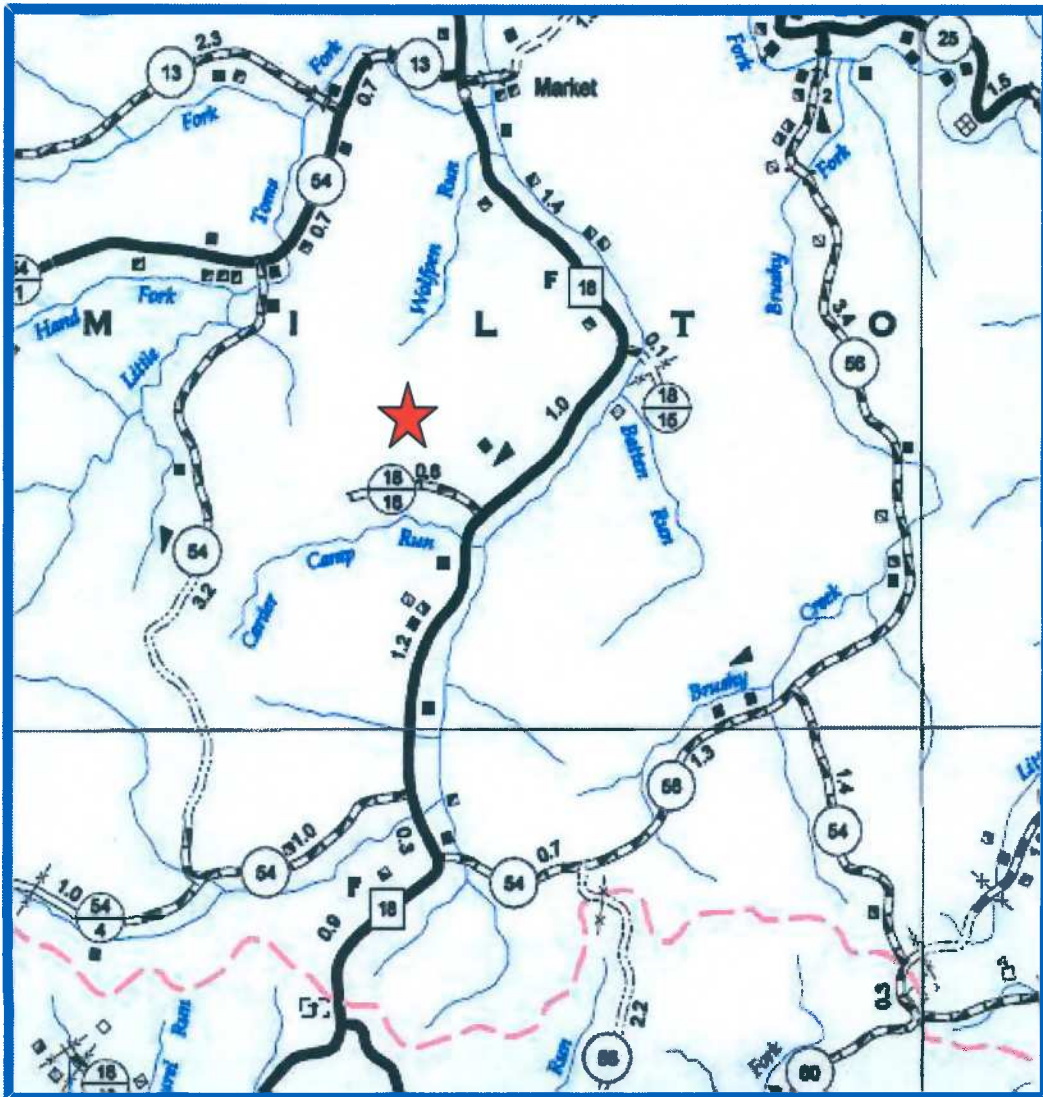

Source: West Virginia Department of Transportation Program Planning and Administration
Division General Highway Map for Doddridge County, West Virginia Last Revision Date February
22, 2011 Sheet 2 of 2.

Site Plan

CENTRALIZED FRESHWATER IMPOUNDMENT PLAN

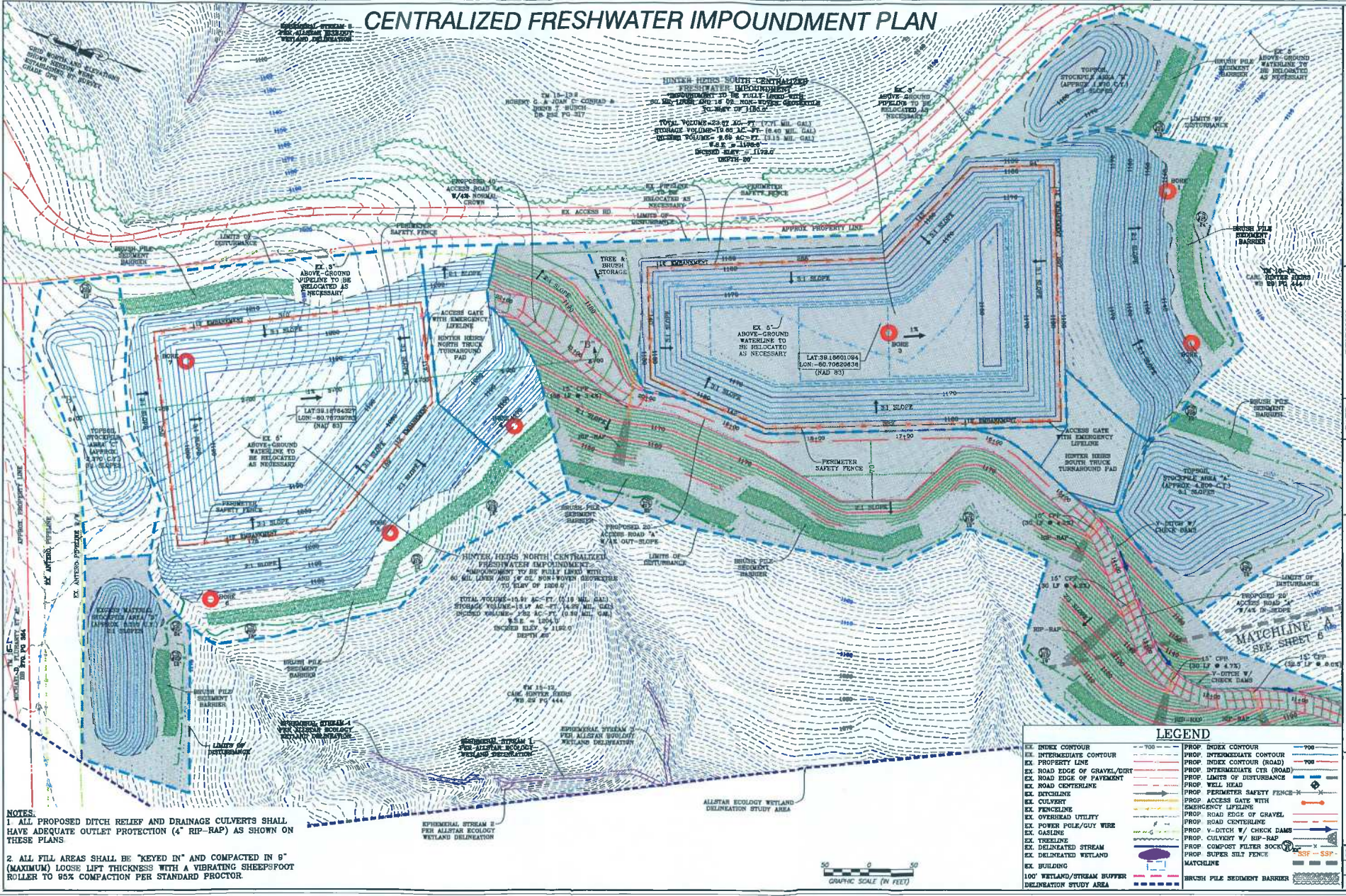

NOTES:
 1. ALL PROPOSED DITCH RELIEF AND DRAINAGE CULVERTS SHALL HAVE ADEQUATE OUTLET PROTECTION (4" RIP-RAP) AS SHOWN ON THESE PLANS.
 2. ALL FILL AREAS SHALL BE "KEYED IN" AND COMPACTED IN 9" (MAXIMUM) LOOSE LIFT THICKNESS WITH A VIBRATING SHEEPSFOOT ROLLER TO 95% COMPACTION PER STANDARD PROCTOR.



LEGEND	
EX INDEX CONTOUR	--- 700 ---
EX INTERMEDIATE CONTOUR	--- 700 ---
EX PROPERTY LINE	---
EX INDEX CONTOUR (ROAD)	---
EX ROAD EDGE OF GRAVEL/DIRT	---
EX ROAD EDGE OF PAVEMENT	---
EX ROAD CENTERLINE	---
EX DITCHLINE	---
EX CULTURE	---
EX FENCELINE	---
EX OVERHEAD UTILITY	---
EX POWER POLE/GUY WIRE	---
EX GASLINE	---
EX TREELINE	---
EX DELINEATED STREAM	---
EX DELINEATED WETLAND	---
EX BUILDING	---
100' WETLAND/STREAM BUFFER DELINEATION STUDY AREA	---
PROP INDEX CONTOUR	--- 700 ---
PROP INTERMEDIATE CONTOUR	---
PROP INDEX CONTOUR (ROAD)	---
PROP LIMITS OF DISTURBANCE	---
PROP WELL HEAD	---
PROP PERIMETER SAFETY FENCE	---
PROP ACCESS GATE WITH EMERGENCY LIFELINE	---
PROP ROAD EDGE OF GRAVEL	---
PROP ROAD CENTERLINE	---
PROP V-DITCH W/ CHECK DAMS	---
PROP CULVERT W/ RIP-RAP	---
PROP COMPOST FILTER SOCK	---
PROP SUPER SILT FENCE	---
MATCHLINE	---
BRUSH PILE SEDIMENT BARRIER	---

NAVITUS ENGINEERING INC.
 43 Wanda Hill Lane
 Winchester, Virginia 22602
 www.navituseng.com

Engineering	Survey	Environmental	GIS
-------------	--------	---------------	-----

DATE:	01/21/2013
REVISION:	

RESOURCES
 THIS DOCUMENT WAS PREPARED BY THE ABOVE LISTED PROFESSIONAL ENGINEER

CENTRALIZED FRESHWATER IMPOUNDMENT PLAN
HINTER HEIRS NORTH
 CENTRALIZED FRESHWATER IMPOUNDMENT
 NEW MILTON DISTRICT
 DODDRIDGE COUNTY, WEST VIRGINIA

DATE: 01/21/2013
 SCALE: 1" = 50'
 SHEET 10 OF 18

PART I - MONITORING PLAN AND INSPECTION SCHEDULE

Section A – Normal Conditions:

During initial filling of the impoundment, visual inspection of the surrounding embankment slopes will be performed by field personnel for every 2 feet of depth increase or every 3 hours of time lapse until the impoundment is full to storage depth, providing 2 feet of freeboard. Once the impoundment is full it will be visually observed by field personnel once every 12 hours for the first week of operation. Following the first week of operation normal inspection frequency shall follow the requirements of W. Va Code §35-4-21 and consist of inspections at a minimum of once every two weeks under normal weather conditions. Upon notice of any change in the embankment condition, filling will immediately cease and the Registered Professional Engineer for that structure will be consulted.

<i>Action</i>	<i>Responsibility</i>	
	Primary Person	Alternate Person
1. Inspect biweekly (once every two weeks) as appropriate to the condition of the impoundment. If a serious problem is found proceed immediately to Section B or C as appropriate. Inspections shall include the following:	Eli Wagoner PH: 304-622-3842 Cell: 304-476-9770	Chris Brown PH: 304-622-3842 Cell: 304-877-8233
<ul style="list-style-type: none"> • Inspect the condition of the exposed / visible geo-membrane liner for deterioration and potential weakening. 	Eli Wagoner PH: 304-622-3842 Cell: 304-476-9770	Chris Brown PH: 304-622-3842 Cell: 304-877-8233
<ul style="list-style-type: none"> • Verify the water level is consistent with the scheduled input and withdrawal of water. 	Dusty Wood PH: 304-622-3842 Cell: 817-771-1436	Chris Brown PH: 304-622-3842 Cell: 304-877-8233
<ul style="list-style-type: none"> • Verify embankments show no signs of movement or instability. 	Eli Wagoner PH: 304-622-3842 Cell: 304-476-9770	Dusty Wood PH: 304-622-3842 Cell: 817-771-1436
<ul style="list-style-type: none"> • Remove debris (tree branches, leaves, trash, etc.) from the impoundment area. 	Eli Wagoner PH: 304-622-3842 Cell: 304-476-9770	Dusty Wood PH: 304-622-3842 Cell: 817-771-1436
<ul style="list-style-type: none"> • Verify the integrity of the security fence and gate. 	Eli Wagoner PH: 304-622-3842 Cell: 304-476-9770	Chris Brown PH: 304-622-3842 Cell: 304-877-8233
<ul style="list-style-type: none"> • Inspect the inflow and outflow pumping systems for degradation to the geomembrane liner and / or berm. 	Chris Brown PH: 304-622-3842 Cell: 304-877-8233	Eli Wagoner PH: 304-622-3842 Cell: 304-476-9770
<ul style="list-style-type: none"> • Look for signs of erosion along the entire face of the berm. 	Eli Wagoner PH: 304-622-3842 Cell: 304-476-9770	Dusty Wood PH: 304-622-3842 Cell: 817-771-1436
<ul style="list-style-type: none"> • Check for potential seeps or piping through the berm. 	Eli Wagoner PH: 304-622-3842 Cell: 304-476-9770	Dusty Wood PH: 304-622-3842 Cell: 817-771-1436
<ul style="list-style-type: none"> • Other: 	Aaron T Kunzler Cell: 405-227-8344	Chris Brown PH: 304-622-3842 Cell: 304-877-8233

Section B – Dangerous Conditions:

The following monitoring and inspection schedule will be used for heavy or extended rainfall, flash flood warnings, earthquake, snow-melt, or serious new problems found under normal conditions such as slips, sinkholes, or piping. Inspection will occur within 24 hours of a heavy rain event, defined as two (2) inches of rain or more in a six (6) hour period. If a problem is observed which could lead to failure, proceed immediately to Section C.

Occurrence of an earthquake of sufficient magnitude to cause structural damage to buildings or property in the general area of the impoundment shall be considered an "adverse condition". Damage from an earthquake may be internal to the impoundment and problems may not appear for days or weeks after the event. The impoundment shall be inspected immediately after the quake and daily for several weeks thereafter. Attention should be directed to looking for cracks, slips, new wet or seepage areas and leakage, both on the face of the berm and in the natural ground areas downstream.

If possible, the impoundment water level shall be decreased prior to forecast extended rainfall or immediately after concerns are observed.

<i>Action</i>	<i>Responsibility</i>	
1. Adverse conditions inspections shall be performed daily or more often as necessary and shall include the following:	Primary Person	Alternate Person
<ul style="list-style-type: none"> Inspect the condition of the exposed / visible geo-membrane liner for deterioration and potential weakening. 	Eli Wagoner PH: 304-622-3842 Cell: 304-476-9770	Chris Brown PH: 304-622-3842 Cell: 304-877-8233
<ul style="list-style-type: none"> Verify the water level is consistent with the scheduled input and withdrawal of water. 	Eli Wagoner PH: 304-622-3842 Cell: 304-476-9770	Dusty Wood PH: 304-622-3842 Cell: 817-771-1436
<ul style="list-style-type: none"> Verify embankments show no signs of movement or instability. 	Aaron T Kunzler Cell: 405-227-8344	Eli Wagoner PH: 304-622-3842 Cell: 304-476-9770
<ul style="list-style-type: none"> Remove debris (tree branches, leaves, trash, etc.) from the impoundment area. 	Aaron T Kunzler Cell: 405-227-8344	Eli Wagoner PH: 304-622-3842 Cell: 304-476-9770
<ul style="list-style-type: none"> Verify the integrity of the security fence and gate. 	Eli Wagoner PH: 304-622-3842 Cell: 304-476-9770	Chris Brown PH: 304-622-3842 Cell: 304-877-8233
<ul style="list-style-type: none"> Inspect the integrity of surface berms and surface runoff water to ensure no uncontrolled or excessive erosion. 	Eli Wagoner PH: 304-622-3842 Cell: 304-476-9770	Chris Brown PH: 304-622-3842 Cell: 304-877-8233
<ul style="list-style-type: none"> Inspect surface berms and up gradient drainage, ensure no surface water flow into impoundment. 	Eli Wagoner PH: 304-622-3842 Cell: 304-476-9770	Chris Brown PH: 304-622-3842 Cell: 304-877-8233
<ul style="list-style-type: none"> Inspect the inflow and outflow pumping systems for degradation to the geomembrane liner and / or berm. 	Dusty Wood PH: 304-622-3842 Cell: 817-771-1436	Eli Wagoner PH: 304-622-3842 Cell: 304-476-9770
<ul style="list-style-type: none"> Look for signs of erosion along the entire face of the berm. 	Eli Wagoner PH: 304-622-3842 Cell: 304-476-9770	Chris Brown PH: 304-622-3842 Cell: 304-877-8233
<ul style="list-style-type: none"> Check for potential seeps or piping through the berm. 	Eli Wagoner PH: 304-622-3842 Cell: 304-476-9770	Chris Brown PH: 304-622-3842 Cell: 304-877-8233
2. If problem is observed which could lead to failure, proceed immediately to Section C	Eli Wagoner PH: 304-622-3842 Cell: 304-476-9770	Dusty Wood PH: 304-622-3842 Cell: 817-771-1436

Section C – Standby Alert:

The following procedure will be used when the condition of impoundment has deteriorated and has been determined to be threatening to the integrity of structure, or the water surface rises to the predetermined critical level of 1 foot above freeboard elevations.

If possible, the impoundment water level shall be decreased as soon as possible after standby alert concerns are observed. The impoundment shall be drawn down to freeboard elevations.

<i>Action</i>	<i>Responsibility</i>	
	Primary Person	Alternate Person
1. Constant surveillance; decrease impoundment or pit volume, if possible.	Dusty Wood PH: 304-622-3842 Cell: 817-771-1436	Eli Wagoner PH: 304-622-3842 Cell: 304-476-9770
<ul style="list-style-type: none"> Monitor the surface elevation of the water and the 2 foot of freeboard. 	Dusty Wood PH: 304-622-3842 Cell: 817-771-1436	Eli Wagoner PH: 304-622-3842 Cell: 304-476-9770
<ul style="list-style-type: none"> Inspect the condition of the exposed / visible geo-membrane liner for deterioration and potential weakening 	Dusty Wood PH: 304-622-3842 Cell: 817-771-1436	Eli Wagoner PH: 304-622-3842 Cell: 304-476-9770
<ul style="list-style-type: none"> Look for signs of erosion along the entire face of the berm. 	Eli Wagoner PH: 304-622-3842 Cell: 304-476-9770	Chris Brown PH: 304-622-3842 Cell: 304-877-8233
<ul style="list-style-type: none"> Inspect the inflow and outflow pumping systems for degradation to the geomembrane liner and / or berm. 	Dusty Wood PH: 304-622-3842 Cell: 817-771-1436	Eli Wagoner PH: 304-622-3842 Cell: 304-476-9770
<ul style="list-style-type: none"> Check for potential seeps or piping through the berm. 	Eli Wagoner PH: 304-622-3842 Cell: 304-476-9770	Dusty Wood PH: 304-622-3842 Cell: 817-771-1436
2. Alert potential affect parties of the danger.	Eli Wagoner PH: 304-622-3842 Cell: 304-476-9770	Chris Brown PH: 304-622-3842 Cell: 304-877-8233

Notify agencies according to checklist in the following tables:

AGENCIES TO BE NOTIFIED		
<u>Check</u>	<u>When Completed</u>	<u>Phone</u>
___	Local 911	911
___	WVDEP Office of Oil and Gas	304-926-0450
___	Local Oil and Gas Inspector - Douglas Newlon	304-932-8049
___	Spill Reporting Number	1-800-642-3074
___	Doddridge County Office of Emergency Services	1-800-782-2124

AGENCY NOTIFICATION CHECKLIST

Check When Completed

- Identify yourself
- Refer to the Impoundments as the Hinte Heirs North Centralized Freshwater Impoundment
- State WVDEP Oil and Gas Impoundment ID # _____.
- Advise the person that you are calling as required by the emergency action plan.
- State the condition of the impoundment.
- State that a standby alert has been declared.
- Advise the person contacted of any requested assistance or action.
- Describe the conditions that warranted the standby alert.
- Describe the immediate danger and risks to surrounding people and property.
- Describe the immediate actions being conducted to avert further danger.
- Answer any questions.
- Document the time and with whom you speak at the notified agencies (Name / title)

If failure of the structure is deemed to be imminent, immediately begin notification and evaluation procedures, as described in Part II, Emergency and Evacuation Plan

PART II- EMERGENCY ACTION AND EVACUATION PLAN

Section A - Notification of Agencies:

Notify the following agencies of an evacuation notice if not already on-site.

AGENCIES TO BE NOTIFIED		
<u>Check</u>	<u>When Completed</u>	<u>Phone</u>
<input type="checkbox"/>	Local 911	911
<input type="checkbox"/>	WVDEP Office of Oil and Gas	304-926-0450
<input type="checkbox"/>	Local Oil and Gas Inspector - Douglas Newlon	304-932-8049
<input type="checkbox"/>	Spill Reporting Number	1-800-642-3074
<input type="checkbox"/>	Doddridge County Office of Emergency Services	1-800-782-2124

Section B – Emergency Evacuation

Working with emergency response personnel and any available company representatives, begin emergency notification of potentially affected surrounding people, residences and businesses, with the objective of moving all people out of harm's way.

Based on Hazard Evaluation and survey, contact the people and organizations on downstream of impoundment that may be impacted by a failure. Inform them of the potential for impending danger and assist them with evacuation to a safe location, if needed.

PART III- POST EVACUATION/ROAD CLOSURE PLAN

Section A - Should No Failure Occur:

ACTION

1. Notify agencies according on checklist below to cancel evacuation order (if not already onsite).

AGENCIES TO BE NOTIFIED		
<u>Check</u>	<u>When Completed</u>	<u>Phone</u>
<input type="checkbox"/>	Local 911	911
<input type="checkbox"/>	WVDEP Office of Oil and Gas	304-926-0450
<input type="checkbox"/>	Local Oil and Gas Inspector - Douglas Newlon	304-932-8049
<input type="checkbox"/>	Spill Reporting Number	1-800-642-3074
<input type="checkbox"/>	West Virginia Department of Highways, County Supervisor	1-304-842-1550
<input type="checkbox"/>	Doddridge County Office of Emergency Services	1-800-782-2124

2. Inform affected parties that the emergency has past and it is safe to return.
3. Immediately begin any efforts to stabilize the structure and/or reduce water volume. An engineering analysis and evaluation will begin to determine root cause of problems and corrective actions.

See Appendix C for Road Closure and Detour Plans.

PART IV - ADMINISTRATION AND RECORD KEEPING

Antero Resources will distribute copies of the Monitoring and Emergency Plan for the Hinter Heirs North Centralized Impoundment within fifteen days (15) after receipt of the WVDEP Office of Oil and Gas approval to the persons named in the distribution list below.

The undersigned states that he/she will distribute a copy of the Monitoring and Emergency Plan for the Hinter Heirs North Centralized Freshwater Impoundment within fifteen days of the WVDEP Office of Oil and Gas approval to the persons named in the Section A – Distribution List below.

Name (Amanda Fernley)	Title	Date
------------------------------	--------------	-------------

Section A - Distribution:

Names and Addresses of all persons or agencies retaining a copy of this plan:

NAME	COMPLETE MAILING ADDRESS
Gene Smith Regulatory Compliance Manager 304-926-0452 ext. 1652	DEP Division of Oil and Gas 601 57 th Street, SE Charleston, WV 25304-2345
Douglas Newlon Local Oil and Gas Inspector 304-932-8049, 304-573-5834	DEP Division of Oil and Gas 4060 Dutchman Road Macfarlan, WV 26248
Mike Headley Doddridge County Sheriff 304-873-1944	Doddridge County Sheriff PO Box 219 West Union, WV 26456
Chris Brown Water Resources 304-877-8233	Antero Resources 175-D Elk Creek Road Mt. Clare, WV 26408
Pat Heaster Director 304-782-2124	Doddridge County Office of Emergency Services 108 Court St. West Union, WV 26456

Section B – Maintenance Plan:

MAINTENANCE PLAN FOR _____ Impoundment ID# _____ 20__

Type of Maintenance	JAN	FEB	MAR	APR	MAY	JUN	JUL	AUG	SEP	OCT	NOV	DEC
Monitoring Plan Inspection	X	X	X	X	X	X	X	X	X	X	X	X
Bi-weekly Facility Inspection	X	X	X	X	X	X	X	X	X	X	X	X
Monthly Inspection Certification Submitted to Office of Oil and Gas	X	X	X	X	X	X	X	X	X	X	X	X
Embankment												
Mow Embankment					X		X		X			
Repair Erosion Gullies			X*	X*	X*	X*	X*	X*	X*	X*	X*	
Revegetate Bare Areas				X			X			X		
Clean Embankment Outlet Pipe			X*	X*	X*	X*	X*	X*	X*	X*	X*	
Repair All Animal Burrows			X*	X*	X*	X*	X*	X*	X*	X*	X*	
Remove Trees/Brush				X			X			X		
Inspect perimeter fencing, ensure access is restricted	X	X	X	X	X	X	X	X	X	X	X	X
Access Gate with Emergency Lifeline	X	X	X	X	X	X	X	X	X	X	X	X

Comments:

* After inspection repair/replace as needed

PART V – HAZARD EVALUATION AND BREACH CALCULATIONS

Section A - Introduction

A.1. Background

Navitus Engineering, Inc. (Navitus) has performed this Impoundment Breach Analysis for the Hinter Heirs North Centralized Freshwater Impoundment as requested by Antero Resources Appalachian Corporation (Antero). In order to construct and operate the facility, a Certificate of Approval for the Centralized Impoundment is required to be obtained through the West Virginia Department of Environmental Protection (WVDEP) Office of Oil and Gas. The centralized impoundment application requires that the proposed impoundment be analyzed in order to determine if a potential impoundment breach would cause serious damage to property, inhabited structures, or roads. Per WVDEP nomenclature, the facility will be referred to as a centralized freshwater impoundment since there is no potential for waste materials to be present. The breach study was completed in accordance with the WVDEP Division of Water Resources, Title 47 Series 34, Dam Safety Rule, dated June 1, 2009. The WVDEP Division of Water Resources Dam Safety Rule suggests the centralized freshwater impoundment is not classified as a dam. A Hydrologic and Hydraulic analysis was performed for the 100-year/24-hour design storm. The downstream reach length was established as the point at which the design storm breach water surface elevation (WSE) is attenuated to have less than 1 foot of impact when compared to the design storm WSE.

The proposed impoundment is located in Doddridge County, West Virginia about 3.5 miles south of New Milton, West Virginia along the northwest side of WV Route 18 and County Route 18/16 (Carder Camp Rd). The centralized freshwater impoundment is located at the top of a ridgeline and has no contributing offsite drainage area. Carder Camp Run is located about 2,200 feet southwest of the proposed centralized freshwater impoundment. A site location map depicting the proposed impoundment location in relation to Carder Camp Run and associated tributaries is provided in Appendix A.

To qualify for the WVDEP Oil and Gas Certification of Approval, the Centralized Impoundment structure shall satisfy the WVDEP Dam Safety requirements. WVDEP Dam Safety definition of an impoundment is as follows:

- An embankment height of 25 feet above natural streambed at the downstream toe to the impoundment crest and impound 15 or more acre-feet of water volume; or
- An embankment rise of 6 feet from natural streambed or at downstream toe to embankment crest and impound 50 or more acre-feet.

Based on the WVDEP Dam Safety Rule, the impoundment height is defined as the vertical height from natural streambed at downstream toe to crest of impoundment. The proposed Hinter

Heirs North Centralized Freshwater Impoundment is partially incised; therefore the maximum impoundment height of 14 feet was measured from the existing ground to impoundment crest.

The impoundment is located along a ridgeline and has an east and west breach scenario. The impoundment height was measured utilizing the crest elevation to the existing grade elevation with 24 inch toe bench/key in. The east breach impoundment height is 5 feet measured from crest elevation of 1,206 to existing ground minus key in at elevation equal to 1,199. The west breach impoundment height is 14 feet measured from crest elevation of 1,206 to existing ground minus key in elevation equal to 1,192. All elevation references are in feet.

The total impoundment storage volume is approximately 15.91 acre-feet at the crest elevation, the incised volume below the existing grade level is 1.82 acre-feet. No discharge or outlet structures are proposed for the impoundment. The maximum operating water surface elevation (WSE) of the impoundment is 1,204, which will provide 2 feet of freeboard. As such, the impoundment appears to be non-jurisdictional under the Dam Safety Rule (WV Code 47-CSR34).

Section B - Hydrologic and Hydraulic Analysis

B.1. General

A hydrologic and hydraulic analysis was prepared to determine if a potential impoundment breach would inundate existing structures or roadways. For this study, two separate scenarios were analyzed:

1. The 100-year/24-hour storm event without impoundment breach
2. The 100-year/24-hour event with impoundment breach

B.2. Base Map

The Site Maps (Appendix A) depict the topography used for the breach study. Topography was derived from aerial mapped 2-foot interval topography by Blue Mountain Aerial Mapping in March 2012 and 10-foot interval topography converted from 3 meter West Virginia GIS Technical Center DEM data. Stream locations were mapped by AllStar Ecology, LLC. This topographic information and stream data were utilized for the base mapping.

B.3. Hydrologic Analysis

The hydrologic analysis utilized USDA soil surveys for computation of drainage shed curve numbers, aerial topography and 3 meter West Virginia GIS Technical Center DEM to determine the drainage area(s) and time of concentration path(s). The peak 100-year discharge within the inundation area was determined through TR-55 SCS methodology. Time of concentration paths were calculated utilizing the SCS lag method. The hydrologic calculations for the drainage area were performed using HEC-HMS. The breaches were modeled within HEC-HMS utilizing a reservoir and dam breach scenario. The breaches utilized a specific time trigger, with the time set at the peak hour found at the downstream junction of Toms Fork. With the peak times matching, this created the worst case scenario for downstream drainage sheds. The breach widths and development times were modeled using Froelich's Dam Break Predictor Equations. The calculated peak flows for the upstream sections to downstream sections are found in the *Miscellaneous Attachments and Design Computations*. The table below is a summary of the drainage computations for the breach flows.

Stream	Computed Flow (cfs)	Average Breach Width (ft)	Time of Failure (hrs)
East Breach	437.7	26.5	0.28
West Breach	1104.2	35.7	0.19

The proposed Hinter Heirs North Centralized Freshwater Impoundment will be constructed by a combination of excavation and the construction of fill embankments. The proposed fill embankments will be constructed on the south, east and west sides of the facility. The

impoundment height of the east embankment will be 5 feet, and the west side impoundment height will be 14 feet.

The potential breach from the east embankment of the proposed impoundment would travel in a southeasterly direction for approximately 3,500 feet before flowing into Toms Fork. The potential breach from the west embankment of the proposed impoundment would travel in a southwesterly direction for approximately 2,300 feet before flowing into Carder Camp Run.

B.4. Hydraulic Analysis

HEC-RAS was used to analyze the downstream flood wave and model the potential impoundment breach. The base map data was utilized to generate the geometry of each cross section. The cross sections were employed at significant changes in site features. This includes major bends in the stream channel, areas of major contraction and expansion of the floodplain area, upstream and downstream of existing culverts, and at building obstructions (cross sections were compiled using Aerial Mapping by Blue Mountain Aerial Mapping). The Overall Site Map (Appendix A) depicts the locations of the critical sections used for the breach study.

A Steady flow analysis was utilized to model the flood wave, and calculate base flood elevations at critical determined cross sections downstream of the breach analysis based upon Hydrologic Data from HEC-HMS. Downstream reach boundary conditions were modeled utilizing the slope of the normal water surface. The proposed site is located in Flood Zone X per FEMA Flood Map #54017C0250C. Two models were prepared: 1. 100 Year-24 Hour Design Storm, 2. 100 Year-24 Hour Design Storm with Breach. The breach flows were modeled in flow change locations. Breach flows were determined using manning's equation, with maximum volumes generated at the incised volume of the breach location. See the *Miscellaneous Attachments and Design Computations* for complete Drainage Computations.

The channel and overbank areas were assigned manning's n-values based on photographs and close inspection of existing aerial photography. The chart below describes the manning's n values used in this study taken from Table 3-1 of the HEC-RAS River Analysis System Hydraulic Reference Manual Version 4.1, January 2010.

Manning's n value	Description	Portion Used
.1	Heavy stand of timber, few down trees, little undergrowth, flow below branches	Floodplains
.035	Clean, straight, full, no rifts or deep pools with more stones and weeds	Main Channel
.04	Clean, winding, some pools and shoals	Main Channel
.035	High grass	Floodplains
.06	Light brush and trees, in summer	Floodplains
.05	Scattered brush, heavy weeds	Floodplains

B.5. Results

A summary of the hydrologic and hydraulic calculations is provided in the *Miscellaneous Attachments and Design Computations*. Further information from the HEC-RAS or HEC-HMS analysis can be provided upon request.

Section C - Results

C.1. 100 year/24 hour Design Storm Routing

During the 100-year/24-hour design storm, flooding is expected to roads along the drainage shed. County Route 18/16 in the study area is inundated between sections 28+06 and 26+80. Flooding also occurs to County Route 18 between sections 15+65 and -6+30. There is no flooding expected to structures in the design model. The proposed drainage model is located in Flood Zone X per FEMA Flood Map #54017C0250C

C.2. 100 year/24 hour Design Storm Routing with Breach

Additional flooding is expected to roads and bridges during the 100-year/24-hour design storm with an impoundment breach. County Routes 18/16 and 18 are already inundated in the 100-year/24-hour design, however the bridge at the intersection of County Routes 18/16 and 18 will be fully inundated with a western breach to the impoundment, see Part VI for necessary road closure measures and signage required in the case of a breach in the impoundment.

C.3. Summary of Results

For each of the evaluated scenarios the summary of results included with the *Miscellaneous Attachments and Design Computations* provides the following information:

- Peak water surface elevations for the West Breach at Section 10+88 at the intersection of County Routes 18/16 and 18 and at Section 26+10 for the East Breach;

Based on the results of the analysis, flooding on County Route 18/16 will occur under the 100 year flood scenario near stations 28+06 to 26+80 and to County Route 18 near stations 15+65 to -6+30. Water surface elevations will raise across Routes 18/16 and 18 with breach flows. A summary table of the hydrologic and hydraulic calculations is provided in the *Miscellaneous Attachments and Design Computations*.

C.4. Reach Length Analysis

The HEC-RAS summary results provide the WSEs at the critical downstream sections resulting from the various scenarios that were evaluated. Comparing the results of the no breach versus impoundment breach scenarios for the 100-year storm, the resulting WSE in section -18+44 of Toms Fork is less than 1-foot of elevation between the 100-year/24-hour design and the breach scenarios . Therefore, the stations represent the downstream terminus of the flood wave routing, and any further downstream impacts from the breach are a negligible threat to human health or the environment.

PART VI – EVACUATION PLAN AND PROCEDURES

The results of this analysis are based on the "worst case scenario" for the breach events, or the 100 year/24 hour Design Storm Routing with Breach. All breach events that occur in **any** event less than that of the aforementioned design are required to follow the same procedures set forth in the sections below.

Section A – Evacuation Plan

Based on the results of the analysis, no additional flooding is expected to any structures located within the drainage study.

Section B – Road Closure Procedures

Based on the results of the analysis, flooding on County Routes 18/16 and 18 will occur under the 100-year/24-hour design scenario and flood waters already inundate the route along the breach route, the additional breach flows will only further inundate the roadway. The road will be closed with detour routes as shown in the Road Closure and Detour Plans found in Appendix C.

All traffic control devices shall be placed in accordance with the West Virginia Manual on Temporary Traffic Control for Streets and Highways, March 2006. The closure of Co. Rt. 25 and 48 shall only occur after authorization by West Virginia Department of Highways. A WVDOH representative shall be onsite during closure activities. All signage along the detour route shall be in accordance with the West Virginia Manual on Temporary Traffic Control for Streets and Highways, March 2006. A WVDOH representative may require other traffic control signs as necessary.

APPENDICES

Appendix A - Site Maps



NAVITUS
 ENGINEERING INC.

151 Wible Hill Lane
 Winchester, Virginia 22602
 Telephone: (888) 662-4185
 www.navituseng.com

Engineering Survey Environmental GIS

CIVIL & SURVEYING
 REGISTERED
 1978
 STATE OF
 WEST VIRGINIA
 PROFESSIONAL ENGINEER

05/31/2013



ANTERO RESOURCES
 THIS DOCUMENT
 WAS PREPARED
 FOR:
 ANTERO RESOURCES
 APPALACHIAN CORP

OVERALL
 SITE MAP
HINTER HEIRS
 NORTH CENTRALIZED
 FRESHWATER IMPOUNDMENT
 NEW MILTON DISTRICT
 DODDRIDGE COUNTY, WV

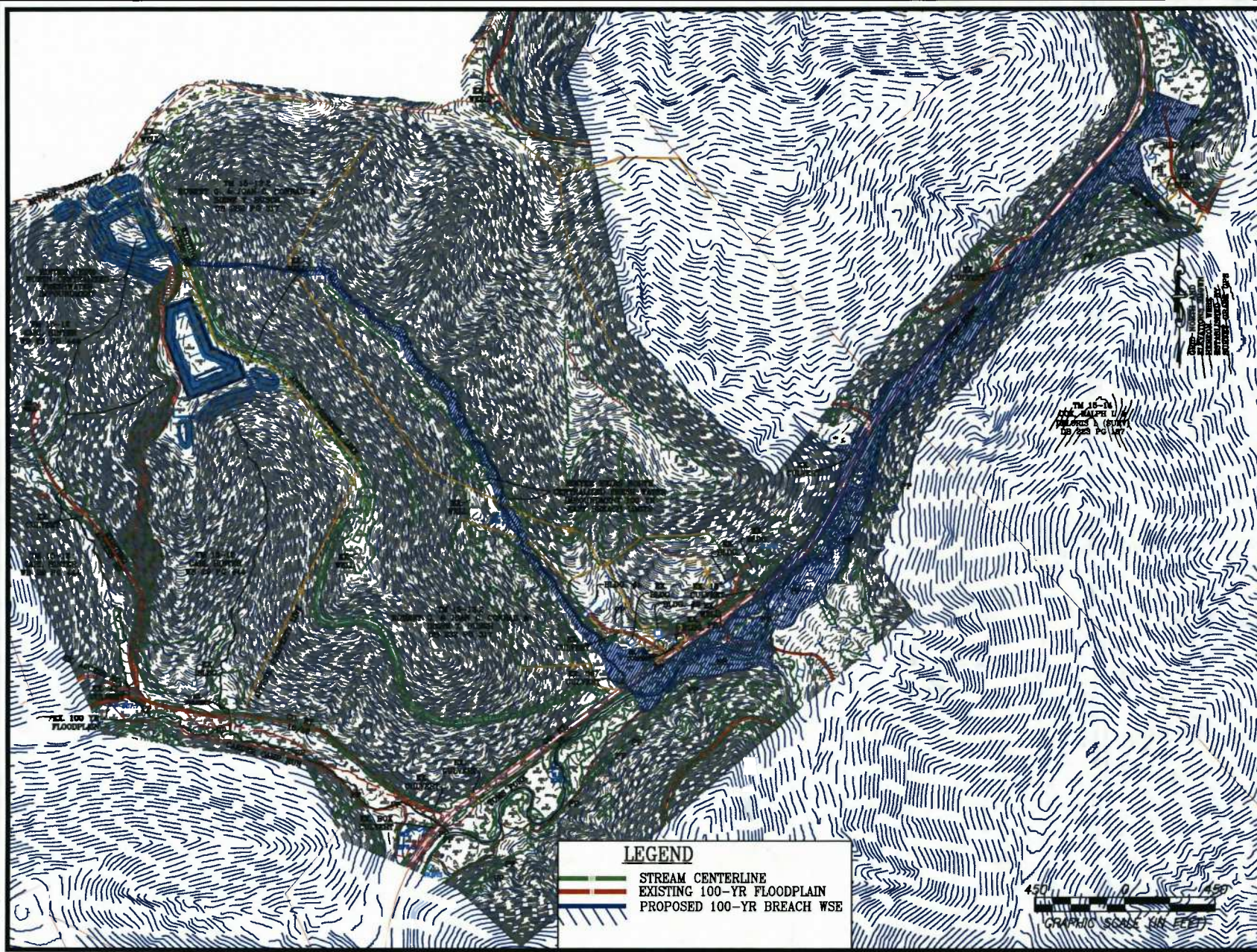
SCALE:	1" = 500'
HINTER HEIRS	
JOB NO. ANT028	
DATE:	05/31/2013
SHEET	A.1



LEGEND

-  STREAM CENTERLINE
-  EXISTING 100-YR FLOODPLAIN
-  PROPOSED 100-YR BREACH WSE





 <p>NAVITUS ENGINEERING INC.</p> <p>151 West Hill Lane Winchester, Virginia 23402 Telephone: (888) 662-4185 www.navituseng.com</p> <p>Engineering Survey Environmental GIS</p>

 <p>ANTERO RESOURCES THIS DOCUMENT WAS PREPARED FOR: ANTERO RESOURCES APPALACHIAN CORP</p>
<p>SITE MAP EAST BREACH HINTER HEIRS NORTH CENTRALIZED FRESHWATER IMPOUNDMENT NEW MILTON DISTRICT DODDRIDGE COUNTY, WV</p>
<p>SCALE: 1" = 450'</p>
<p>HINTER HEIRS JOB NO. ANT028</p>
<p>DATE: 05/31/2013</p>
<p>SHEET A.2</p>



LEGEND

-  STREAM CENTERLINE
-  EXISTING 100-YR FLOODPLAIN
-  PROPOSED 100-YR BREACH WSE



NAVITUS
ENGINEERING INC.

151 Wade Hill Lane
Winchester, Virginia 22602
Telephone: (888) 662-4185
www.navituseg.com

Engineering Survey Environmental GIS

REGISTERED PROFESSIONAL ENGINEER
STATE OF WEST VIRGINIA
1978

CYRUS S. KUMAR

05/31/2013

ANTERO RESOURCES

THIS DOCUMENT WAS PREPARED FOR:
ANTERO RESOURCES
APPALACHIAN CORP.

SITE MAP
WEST BREACH
HINTER HEIRS
NORTH CENTRALIZED
FRESHWATER IMPOUNDMENT
NEW MILTON DISTRICT
DODDRIDGE COUNTY, WV

SCALE: 1" = 450'

HINTER HEIRS
JOB NO. ANT028

DATE: 05/31/2013

SHEET A.3

MAINTENANCE, MONITORING, AND
EMERGENCY ACTION PLAN
**HINTER HEIRS NORTH CENTRALIZED
FRESHWATER IMPOUNDMENT**

ID# _____



VICINITY MAP

1" = 2,000'



NAVITUS
ENGINEERING INC.

151 Windy Hill Lane
Winchester, VA 22602
Telephone: (888) 662-4185
www.navituseng.com

Prepared For:

Engineering ◀ Survey ◀ Environmental ◀ GIS



ANTERO
RESOURCES
981 East Washington Avenue
Ellenboro, WV 26346
(304) 869-3405

Contacts:
Aaron Kunzler, Construction Supervisor
(405) 227-8344
Anthony Smith, Field Engineer
(304) 673-6196
Jack Bell, Land Agent
(304) 376-9682
Chris Brown, Water Resources
(304) 877-8233



Revised: May 31, 2013
Date: January 21, 2013

Designed By:
Navitus Engineering Inc.

Project Manager:
Cyrus Kump, PE
ckump@navituseng.com

Surface Owner (s)
Carl Hinter Heirs

Tax Parcel:
Map 15 Parcel 12

Location:
New Milton District, Doddridge County
West Virginia

FN# ANT028

TABLE OF CONTENTS

INTRODUCTION.....	2
Road Map.....	3
Site Plan	4
PART I - MONITORING PLAN AND INSPECTION SCHEDULE.....	5
Section A – Normal Conditions:.....	5
Section B – Dangerous Conditions:.....	6
Section C – Standby Alert:	7
PART II- EMERGENCY ACTION AND EVACUATION PLAN.....	9
Section A - Notification of Agencies:.....	9
PART III- POST EVACUATION/ROAD CLOSURE PLAN.....	10
Section A - Should No Failure Occur:.....	10
PART IV - ADMINISTRATION AND RECORD KEEPING	11
Section A - Distribution:.....	11
Section B – Maintenance Plan:	Error! Bookmark not defined.
Section C – Inspection Record.....	13
PART V – HAZARD EVALUATION AND BREACH CALCULATIONS	14
Section A - Introduction	14
A.1. Background.....	14
Section B - Hydrologic and Hydraulic Analysis	16
B.1. General.....	16
B.2. Base Map.....	16
B.3. Hydrologic Analysis	16
B.4. Hydraulic Analysis	17
B.5. Results	18
Section C - Results.....	19
C.1. 100 year/24 hour Design Storm Routing.....	19
C.2. 100 year/24 hour Design Storm Routing with Breach	19
C.3. Summary of Results	19
C.4. Reach Length Analysis	19
PART VI – EVACUATION PLAN AND PROCEDURES.....	20
Section A – Evacuation Plan	20
Section B – Road Closure Procedures	20
APPENDICES.....	21
Appendix A - Site Maps	21
Appendix B - Residence and Neighboring Property Survey	22
Appendix C- Road Closure and Detour Plans	23

INTRODUCTION

Purpose of Plan:

The purpose of this document is to provide for monitoring of the Hinter Heirs North Centralized Freshwater Impoundment under various conditions so that an emergency situation at the impoundment will be observed promptly and reported to agencies and persons who may be affected. This document also provides a plan for the orderly notification and evacuation of downstream residents to a place of safety in the event of a potential or actual impoundment failure.

Brief Overview of Impoundment:

The Hinter Heirs North Centralized Freshwater Impoundment is an earthen structure on a ridge adjacent to Carder Camp Run. The centralized freshwater impoundment has a maximum exterior embankment height of 38.0 feet and impounds a maximum water volume of 15.91 acre-feet with 1.82 acre-feet being contained within the incised portion of the impoundment (non-incised available water storage volume to embankment top is 14.09 acre-feet). The impoundment was designed by a WV registered professional engineer and its construction shall be certified by a West Virginia registered professional engineer prior to filling. The impoundment will be constructed with an impervious 60 mil. HDPE geo-membrane and a 16 oz. non-woven geotextile layer. The impoundment will be filled using a waterline pumping freshwater from various sources per the approved Water Management Plan (WMP). The inflow and outflow of water will be controlled by portable pumps to maintain a normal freeboard of 2 feet.

Impoundment Location:

The Hinter Heirs North Centralized Freshwater Impoundment is located on a ridge north of the intersection of WV Rt. 18 and Co. Rt. 18/16 (Carder Camp Road). The access road for the site is approximately 0.31 miles northwest of the intersection along Carder Camp Road. The site is adjacent to Carder Camp Run and is located south of New Milton in the Central District of Doddridge County, WV. The impoundment is approximately 2,200 feet from Co. Rt. 18/16 (Carder Camp Road) on a private access road.

How to Use This Document:

Persons using this plan will find a sequence of actions to be taken depending on rainfall and site conditions. A summary of where to find specific monitoring, reporting, and evacuation requirements can be found on the Table of Contents (See Previous Page).

Road Map

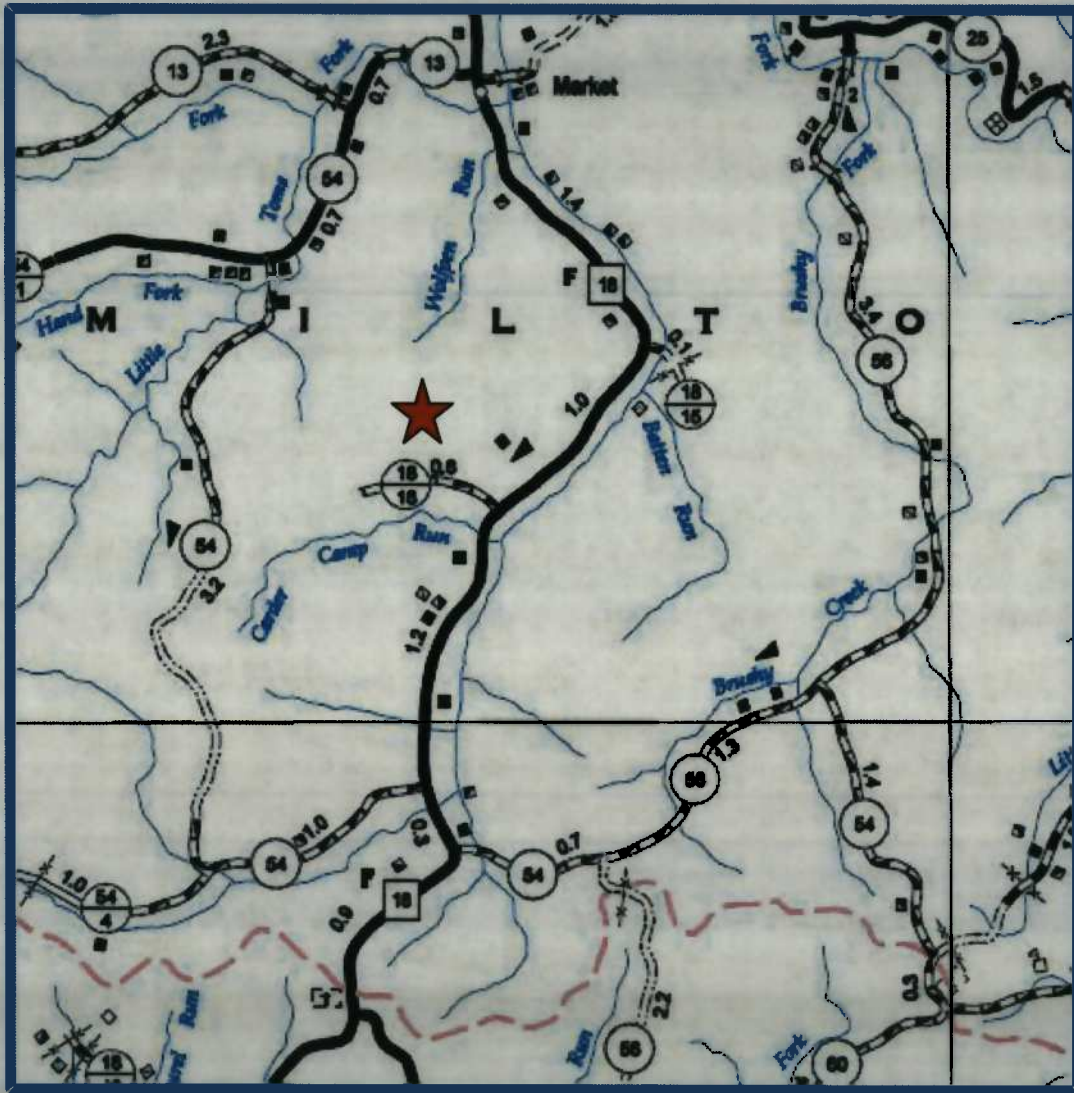

Source: West Virginia Department of Transportation Program Planning and Administration
Division General Highway Map for Doddridge County, West Virginia Last Revision Date February
22, 2011 Sheet 2 of 2.

Site Plan

CENTRALIZED FRESHWATER IMPOUNDMENT PLAN

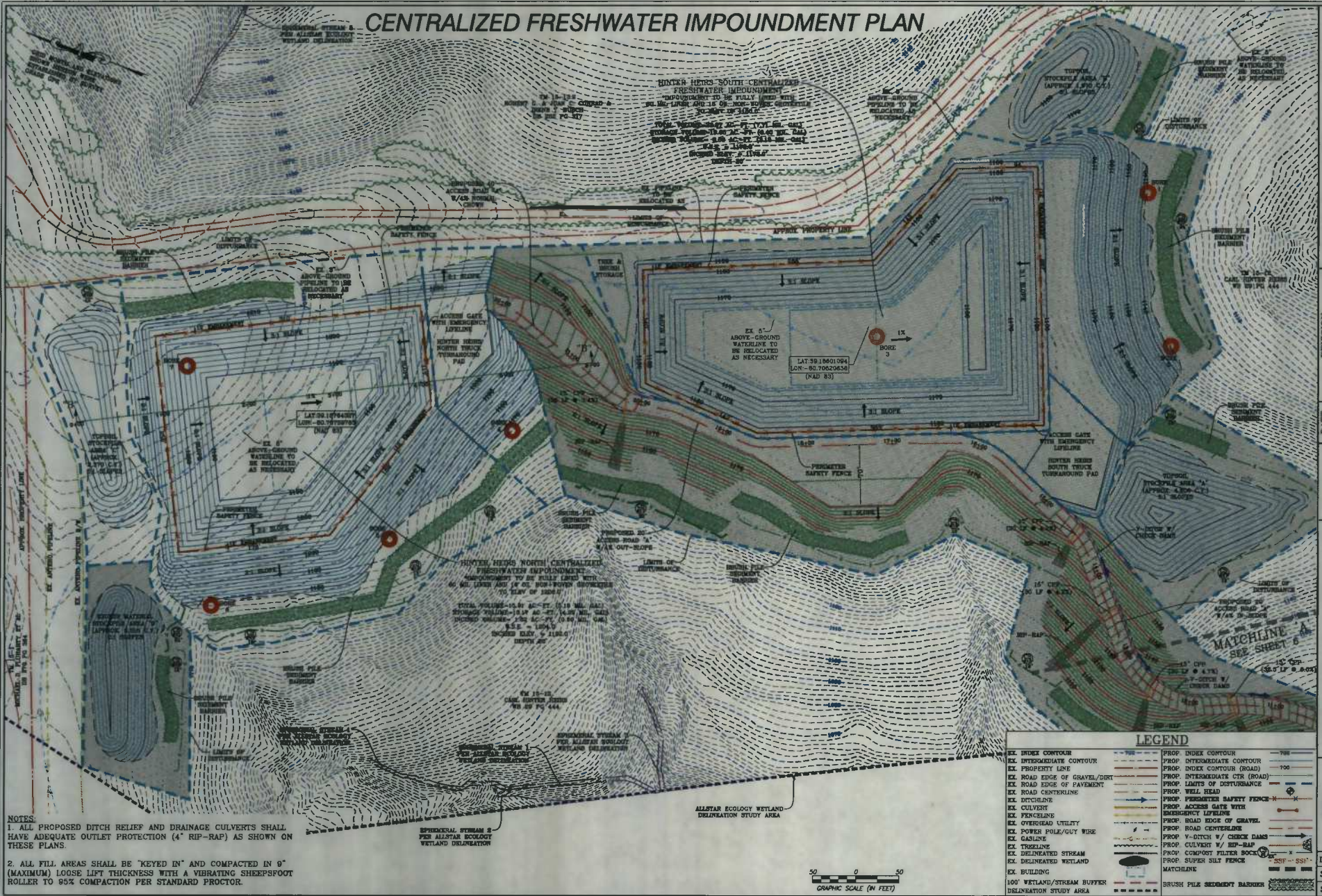

NOTES

1. ALL PROPOSED DITCH RELIEF AND DRAINAGE CULVERTS SHALL HAVE ADEQUATE OUTLET PROTECTION (4" RIP-RAP) AS SHOWN ON THESE PLANS.
2. ALL FILL AREAS SHALL BE "KEYED IN" AND COMPACTED IN 9" (MAXIMUM) LOOSE LIFT THICKNESS WITH A VIBRATING SHEEPSFOOT ROLLER TO 95% COMPACTION PER STANDARD PROCTOR.

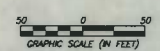

LEGEND	
EX. INDEX CONTOUR	PROF. INDEX CONTOUR
EX. INTERMEDIATE CONTOUR	PROF. INTERMEDIATE CONTOUR
EX. PROPERTY LINE	PROF. INDEX CONTOUR (ROAD)
EX. ROAD EDGE OF GRAVEL/DIRT	PROF. INTERMEDIATE CTR (ROAD)
EX. ROAD EDGE OF PAVEMENT	PROF. LIMITS OF DISTURBANCE
EX. ROAD CENTERLINE	PROF. PERIMETER SAFETY FENCE
EX. DITCHLINE	PROF. ACCESS GATE WITH EMERGENCY LIFELINE
EX. CULVERT	PROF. ROAD EDGE OF GRAVEL
EX. FENCELINE	PROF. OVERHEAD UTILITY
EX. POWER POLE/GUY WIRE	PROF. POWER POLE/GUY WIRE
EX. GASLINE	PROF. GASLINE
EX. TRENCHLINE	PROF. TRENCHLINE
EX. DELINEATED STREAM	PROF. DELINEATED STREAM
EX. DELINEATED WETLAND	PROF. DELINEATED WETLAND
EX. BUILDING	PROF. BUILDING
100' WETLAND/STREAM BUFFER	100' WETLAND/STREAM BUFFER
DELINEATION STUDY AREA	DELINEATION STUDY AREA
	PROF. SUPER SILT FENCE
	MATCHLINE
	BRUSH PILE SEDIMENT BARRIER

NAVITUS ENGINEERING INC.
 111 Brady Hill Lane
 Raleigh, NC 27601
 Phone: (919) 876-1111
 Fax: (919) 876-1112
 www.navituseng.com

Engineering Survey Environmental GIS

DATE: 01/21/2013
 SCALE: 1" = 50'
 SHEET 10 OF 16

CENTRALIZED FRESHWATER IMPOUNDMENT PLAN
HINTER HEIRS NORTH
 CENTRALIZED FRESHWATER IMPOUNDMENT
 NEW MILTON DISTRICT
 DODDRIIDGE COUNTY, WEST VIRGINIA

ARTURO RESOURCES
 THE DOCUMENT PREPARED BY THIS FIRM IS THE PROPERTY OF ARTURO RESOURCES AND IS NOT TO BE REPRODUCED OR TRANSMITTED IN ANY FORM OR BY ANY MEANS, ELECTRONIC OR MECHANICAL, INCLUDING PHOTOCOPYING, RECORDING, OR BY ANY INFORMATION STORAGE AND RETRIEVAL SYSTEM, WITHOUT THE WRITTEN PERMISSION OF ARTURO RESOURCES.

DATE: 01/21/2013
 SCALE: 1" = 50'
 SHEET 10 OF 16

PART I - MONITORING PLAN AND INSPECTION SCHEDULE

Section A – Normal Conditions:

During initial filling of the impoundment, visual inspection of the surrounding embankment slopes will be performed by field personnel for every 2 feet of depth increase or every 3 hours of time lapse until the impoundment is full to storage depth, providing 2 feet of freeboard. Once the impoundment is full it will be visually observed by field personnel once every 12 hours for the first week of operation. Following the first week of operation normal inspection frequency shall follow the requirements of W. Va Code §35-4-21 and consist of inspections at a minimum of once every two weeks under normal weather conditions. Upon notice of any change in the embankment condition, filling will immediately cease and the Registered Professional Engineer for that structure will be consulted.

<i>Action</i>	<i>Responsibility</i>	
	Primary Person	Alternate Person
1. Inspect biweekly (once every two weeks) as appropriate to the condition of the impoundment. If a serious problem is found proceed immediately to Section B or C as appropriate. Inspections shall include the following:	Eli Wagoner PH: 304-622-3842 Cell: 304-476-9770	Chris Brown PH: 304-622-3842 Cell: 304-877-8233
<ul style="list-style-type: none"> • Inspect the condition of the exposed / visible geo-membrane liner for deterioration and potential weakening. 	Eli Wagoner PH: 304-622-3842 Cell: 304-476-9770	Chris Brown PH: 304-622-3842 Cell: 304-877-8233
<ul style="list-style-type: none"> • Verify the water level is consistent with the scheduled input and withdrawal of water. 	Dusty Wood PH: 304-622-3842 Cell: 817-771-1436	Chris Brown PH: 304-622-3842 Cell: 304-877-8233
<ul style="list-style-type: none"> • Verify embankments show no signs of movement or instability. 	Eli Wagoner PH: 304-622-3842 Cell: 304-476-9770	Dusty Wood PH: 304-622-3842 Cell: 817-771-1436
<ul style="list-style-type: none"> • Remove debris (tree branches, leaves, trash, etc.) from the impoundment area. 	Eli Wagoner PH: 304-622-3842 Cell: 304-476-9770	Dusty Wood PH: 304-622-3842 Cell: 817-771-1436
<ul style="list-style-type: none"> • Verify the integrity of the security fence and gate. 	Eli Wagoner PH: 304-622-3842 Cell: 304-476-9770	Chris Brown PH: 304-622-3842 Cell: 304-877-8233
<ul style="list-style-type: none"> • Inspect the inflow and outflow pumping systems for degradation to the geomembrane liner and / or berm. 	Chris Brown PH: 304-622-3842 Cell: 304-877-8233	Eli Wagoner PH: 304-622-3842 Cell: 304-476-9770
<ul style="list-style-type: none"> • Look for signs of erosion along the entire face of the berm. 	Eli Wagoner PH: 304-622-3842 Cell: 304-476-9770	Dusty Wood PH: 304-622-3842 Cell: 817-771-1436
<ul style="list-style-type: none"> • Check for potential seeps or piping through the berm. 	Eli Wagoner PH: 304-622-3842 Cell: 304-476-9770	Dusty Wood PH: 304-622-3842 Cell: 817-771-1436
<ul style="list-style-type: none"> • Other: 	Aaron T Kunzler Cell: 405-227-8344	Chris Brown PH: 304-622-3842 Cell: 304-877-8233

Section B – Dangerous Conditions:

The following monitoring and inspection schedule will be used for heavy or extended rainfall, flash flood warnings, earthquake, snow-melt, or serious new problems found under normal conditions such as slips, sinkholes, or piping. Inspection will occur within 24 hours of a heavy rain event, defined as two (2) inches of rain or more in a six (6) hour period. If a problem is observed which could lead to failure, proceed immediately to Section C.

Occurrence of an earthquake of sufficient magnitude to cause structural damage to buildings or property in the general area of the impoundment shall be considered an "adverse condition". Damage from an earthquake may be internal to the impoundment and problems may not appear for days or weeks after the event. The impoundment shall be inspected immediately after the quake and daily for several weeks thereafter. Attention should be directed to looking for cracks, slips, new wet or seepage areas and leakage, both on the face of the berm and in the natural ground areas downstream.

If possible, the impoundment water level shall be decreased prior to forecast extended rainfall or immediately after concerns are observed.

<i>Action</i>	<i>Responsibility</i>	
	Primary Person	Alternate Person
1. Adverse conditions inspections shall be performed daily or more often as necessary and shall include the following:	Eli Wagoner PH: 304-622-3842 Cell: 304-476-9770	Chris Brown PH: 304-622-3842 Cell: 304-877-8233
• Inspect the condition of the exposed / visible geo-membrane liner for deterioration and potential weakening.	Eli Wagoner PH: 304-622-3842 Cell: 304-476-9770	Chris Brown PH: 304-622-3842 Cell: 304-877-8233
• Verify the water level is consistent with the scheduled input and withdrawal of water.	Eli Wagoner PH: 304-622-3842 Cell: 304-476-9770	Dusty Wood PH: 304-622-3842 Cell: 817-771-1436
• Verify embankments show no signs of movement or instability.	Aaron T Kunzler Cell: 405-227-8344	Eli Wagoner PH: 304-622-3842 Cell: 304-476-9770
• Remove debris (tree branches, leaves, trash, etc.) from the impoundment area.	Aaron T Kunzler Cell: 405-227-8344	Eli Wagoner PH: 304-622-3842 Cell: 304-476-9770
• Verify the integrity of the security fence and gate.	Eli Wagoner PH: 304-622-3842 Cell: 304-476-9770	Chris Brown PH: 304-622-3842 Cell: 304-877-8233
• Inspect the integrity of surface berms and surface runoff water to ensure no uncontrolled or excessive erosion.	Eli Wagoner PH: 304-622-3842 Cell: 304-476-9770	Chris Brown PH: 304-622-3842 Cell: 304-877-8233
• Inspect surface berms and up gradient drainage, ensure no surface water flow into impoundment.	Eli Wagoner PH: 304-622-3842 Cell: 304-476-9770	Chris Brown PH: 304-622-3842 Cell: 304-877-8233
• Inspect the inflow and outflow pumping systems for degradation to the geomembrane liner and / or berm.	Dusty Wood PH: 304-622-3842 Cell: 817-771-1436	Eli Wagoner PH: 304-622-3842 Cell: 304-476-9770
• Look for signs of erosion along the entire face of the berm.	Eli Wagoner PH: 304-622-3842 Cell: 304-476-9770	Chris Brown PH: 304-622-3842 Cell: 304-877-8233
• Check for potential seeps or piping through the berm.	Eli Wagoner PH: 304-622-3842 Cell: 304-476-9770	Chris Brown PH: 304-622-3842 Cell: 304-877-8233
2. If problem is observed which could lead to failure, proceed immediately to Section C	Eli Wagoner PH: 304-622-3842 Cell: 304-476-9770	Dusty Wood PH: 304-622-3842 Cell: 817-771-1436

Section C – Standby Alert:

The following procedure will be used when the condition of impoundment has deteriorated and has been determined to be threatening to the integrity of structure, or the water surface rises to the predetermined critical level of 1 foot above freeboard elevations.

If possible, the impoundment water level shall be decreased as soon as possible after standby alert concerns are observed. The impoundment shall be drawn down to freeboard elevations.

<i>Action</i>	<i>Responsibility</i>	
	Primary Person	Alternate Person
1. Constant surveillance; decrease impoundment or pit volume, if possible.	Dusty Wood PH: 304-622-3842 Cell: 817-771-1436	Eli Wagoner PH: 304-622-3842 Cell: 304-476-9770
• Monitor the surface elevation of the water and the 2 foot of freeboard.	Dusty Wood PH: 304-622-3842 Cell: 817-771-1436	Eli Wagoner PH: 304-622-3842 Cell: 304-476-9770
• Inspect the condition of the exposed / visible geo-membrane liner for deterioration and potential weakening	Dusty Wood PH: 304-622-3842 Cell: 817-771-1436	Eli Wagoner PH: 304-622-3842 Cell: 304-476-9770
• Look for signs of erosion along the entire face of the berm.	Eli Wagoner PH: 304-622-3842 Cell: 304-476-9770	Chris Brown PH: 304-622-3842 Cell: 304-877-8233
• Inspect the inflow and outflow pumping systems for degradation to the geomembrane liner and / or berm.	Dusty Wood PH: 304-622-3842 Cell: 817-771-1436	Eli Wagoner PH: 304-622-3842 Cell: 304-476-9770
• Check for potential seeps or piping through the berm.	Eli Wagoner PH: 304-622-3842 Cell: 304-476-9770	Dusty Wood PH: 304-622-3842 Cell: 817-771-1436
2. Alert potential affect parties of the danger.	Eli Wagoner PH: 304-622-3842 Cell: 304-476-9770	Chris Brown PH: 304-622-3842 Cell: 304-877-8233

Notify agencies according to checklist in the following tables:

AGENCIES TO BE NOTIFIED		
<u>Check</u>	<u>When Completed</u>	<u>Phone</u>
___	Local 911	911
___	WVDEP Office of Oil and Gas	304-926-0450
___	Local Oil and Gas Inspector - Douglas Newlon	304-932-8049
___	Spill Reporting Number	1-800-642-3074
___	Doddridge County Office of Emergency Services	1-800-782-2124

AGENCY NOTIFICATION CHECKLIST

Check When Completed

- ___ Identify yourself
- ___ Refer to the Impoundments as the Hinter Heirs North Centralized Freshwater Impoundment
- ___ State WVDEP Oil and Gas Impoundment ID # _____.
- ___ Advise the person that you are calling as required by the emergency action plan.
- ___ State the condition of the impoundment.
- ___ State that a standby alert has been declared.
- ___ Advise the person contacted of any requested assistance or action.
- ___ Describe the conditions that warranted the standby alert.
- ___ Describe the immediate danger and risks to surrounding people and property.
- ___ Describe the immediate actions being conducted to avert further danger.
- ___ Answer any questions.
- ___ Document the time and with whom you speak at the notified agencies (Name / title)

If failure of the structure is deemed to be imminent, immediately begin notification and evaluation procedures, as described in Part II, Emergency and Evacuation Plan

PART II- EMERGENCY ACTION AND EVACUATION PLAN

Section A - Notification of Agencies:

Notify the following agencies of an evacuation notice if not already on-site.

AGENCIES TO BE NOTIFIED		
<u>Check</u>	<u>When Completed</u>	<u>Phone</u>
<input type="checkbox"/>	Local 911	911
<input type="checkbox"/>	WVDEP Office of Oil and Gas	304-926-0450
<input type="checkbox"/>	Local Oil and Gas Inspector - Douglas Newlon	304-932-8049
<input type="checkbox"/>	Spill Reporting Number	1-800-642-3074
<input type="checkbox"/>	Doddridge County Office of Emergency Services	1-800-782-2124

Section B – Emergency Evacuation

Working with emergency response personnel and any available company representatives, begin emergency notification of potentially affected surrounding people, residences and businesses, with the objective of moving all people out of harm's way.

Based on Hazard Evaluation and survey, contact the people and organizations on downstream of impoundment that may be impacted by a failure. Inform them of the potential for impending danger and assist them with evacuation to a safe location, if needed.

PART III- POST EVACUATION/ROAD CLOSURE PLAN

Section A - Should No Failure Occur:

ACTION

1. Notify agencies according on checklist below to cancel evacuation order (if not already onsite).

AGENCIES TO BE NOTIFIED

<u>Check When Completed</u>		<u>Phone</u>
<input type="checkbox"/>	Local 911	911
<input type="checkbox"/>	WVDEP Office of Oil and Gas	304-926-0450
<input type="checkbox"/>	Local Oil and Gas Inspector - Douglas Newlon	304-932-8049
<input type="checkbox"/>	Spill Reporting Number	1-800-642-3074
<input type="checkbox"/>	West Virginia Department of Highways, County Supervisor	1-304-842-1550
<input type="checkbox"/>	Doddridge County Office of Emergency Services	1-800-782-2124

2. Inform affected parties that the emergency has past and it is safe to return.
3. Immediately begin any efforts to stabilize the structure and/or reduce water volume. An engineering analysis and evaluation will begin to determine root cause of problems and corrective actions.

See Appendix C for Road Closure and Detour Plans.

PART IV - ADMINISTRATION AND RECORD KEEPING

Antero Resources will distribute copies of the Monitoring and Emergency Plan for the Hinter Heirs North Centralized Impoundment within fifteen days (15) after receipt of the WVDEP Office of Oil and Gas approval to the persons named in the distribution list below.

The undersigned states that he/she will distribute a copy of the Monitoring and Emergency Plan for the Hinter Heirs North Centralized Freshwater Impoundment within fifteen days of the WVDEP Office of Oil and Gas approval to the persons named in the Section A – Distribution List below.

Name (Amanda Fernley)	Title	Date
------------------------------	--------------	-------------

Section A - Distribution:

Names and Addresses of all persons or agencies retaining a copy of this plan:

NAME	COMPLETE MAILING ADDRESS
Gene Smith Regulatory Compliance Manager 304-926-0452 ext. 1652	DEP Division of Oil and Gas 601 57 th Street, SE Charleston, WV 25304-2345
Douglas Newlon Local Oil and Gas Inspector 304-932-8049, 304-573-5834	DEP Division of Oil and Gas 4060 Dutchman Road Macfarlan, WV 26248
Mike Headley Doddridge County Sheriff 304-873-1944	Doddridge County Sheriff PO Box 219 West Union, WV 26456
Chris Brown Water Resources 304-877-8233	Antero Resources 175-D Elk Creek Road Mt. Clare, WV 26408
Pat Heaster Director 304-782-2124	Doddridge County Office of Emergency Services 108 Court St. West Union, WV 26456

Section B – Maintenance Plan:

MAINTENANCE PLAN FOR _____ Impoundment ID# _____ 20__

Type of Maintenance	JAN	FEB	MAR	APR	MAY	JUN	JUL	AUG	SEP	OCT	NOV	DEC
Monitoring Plan Inspection	X	X	X	X	X	X	X	X	X	X	X	X
Bi-weekly Facility Inspection	X	X	X	X	X	X	X	X	X	X	X	X
Monthly Inspection Certification Submitted to Office of Oil and Gas	X	X	X	X	X	X	X	X	X	X	X	X
Embankment												
Mow Embankment					X		X		X			
Repair Erosion Gullies			X*	X*	X*	X*	X*	X*	X*	X*	X*	
Revegetate Bare Areas				X			X			X		
Clean Embankment Outlet Pipe			X*	X*	X*	X*	X*	X*	X*	X*	X*	
Repair All Animal Burrows			X*	X*	X*	X*	X*	X*	X*	X*	X*	
Remove Trees/Brush				X			X			X		
Inspect perimeter fencing, ensure access is restricted	X	X	X	X	X	X	X	X	X	X	X	X
Access Gate with Emergency Lifeline	X	X	X	X	X	X	X	X	X	X	X	X

Comments:

*** After inspection repair/replace as needed**

PART V – HAZARD EVALUATION AND BREACH CALCULATIONS

Section A - Introduction

A.1. Background

Navitus Engineering, Inc. (Navitus) has performed this Impoundment Breach Analysis for the Hinter Heirs North Centralized Freshwater Impoundment as requested by Antero Resources Appalachian Corporation (Antero). In order to construct and operate the facility, a Certificate of Approval for the Centralized Impoundment is required to be obtained through the West Virginia Department of Environmental Protection (WVDEP) Office of Oil and Gas. The centralized impoundment application requires that the proposed impoundment be analyzed in order to determine if a potential impoundment breach would cause serious damage to property, inhabited structures, or roads. Per WVDEP nomenclature, the facility will be referred to as a centralized freshwater impoundment since there is no potential for waste materials to be present. The breach study was completed in accordance with the WVDEP Division of Water Resources, Title 47 Series 34, Dam Safety Rule, dated June 1, 2009. The WVDEP Division of Water Resources Dam Safety Rule suggests the centralized freshwater impoundment is not classified as a dam. A Hydrologic and Hydraulic analysis was performed for the 100-year/24-hour design storm. The downstream reach length was established as the point at which the design storm breach water surface elevation (WSE) is attenuated to have less than 1 foot of impact when compared to the design storm WSE.

The proposed impoundment is located in Doddridge County, West Virginia about 3.5 miles south of New Milton, West Virginia along the northwest side of WV Route 18 and County Route 18/16 (Carder Camp Rd). The centralized freshwater impoundment is located at the top of a ridgeline and has no contributing offsite drainage area. Carder Camp Run is located about 2,200 feet southwest of the proposed centralized freshwater impoundment. A site location map depicting the proposed impoundment location in relation to Carder Camp Run and associated tributaries is provided in Appendix A.

To qualify for the WVDEP Oil and Gas Certification of Approval, the Centralized Impoundment structure shall satisfy the WVDEP Dam Safety requirements. WVDEP Dam Safety definition of an impoundment is as follows:

- An embankment height of 25 feet above natural streambed at the downstream toe to the impoundment crest and impound 15 or more acre-feet of water volume; or
- An embankment rise of 6 feet from natural streambed or at downstream toe to embankment crest and impound 50 or more acre-feet.

Based on the WVDEP Dam Safety Rule, the impoundment height is defined as the vertical height from natural streambed at downstream toe to crest of impoundment. The proposed Hinter

Heirs North Centralized Freshwater Impoundment is partially incised; therefore the maximum impoundment height of 14 feet was measured from the existing ground to impoundment crest.

The impoundment is located along a ridgeline and has an east and west breach scenario. The impoundment height was measured utilizing the crest elevation to the existing grade elevation with 24 inch toe bench/key in. The east breach impoundment height is 5 feet measured from crest elevation of 1,206 to existing ground minus key in at elevation equal to 1,199. The west breach impoundment height is 14 feet measured from crest elevation of 1,206 to existing ground minus key in elevation equal to 1,192. All elevation references are in feet.

The total impoundment storage volume is approximately 15.91 acre-feet at the crest elevation, the incised volume below the existing grade level is 1.82 acre-feet. No discharge or outlet structures are proposed for the impoundment. The maximum operating water surface elevation (WSE) of the impoundment is 1,204, which will provide 2 feet of freeboard. As such, the impoundment appears to be non-jurisdictional under the Dam Safety Rule (WV Code 47-CSR34).

Section B - Hydrologic and Hydraulic Analysis

B.1. General

A hydrologic and hydraulic analysis was prepared to determine if a potential impoundment breach would inundate existing structures or roadways. For this study, two separate scenarios were analyzed:

1. The 100-year/24-hour storm event without impoundment breach
2. The 100-year/24-hour event with impoundment breach

B.2. Base Map

The Site Maps (Appendix A) depict the topography used for the breach study. Topography was derived from aerial mapped 2-foot interval topography by Blue Mountain Aerial Mapping in March 2012 and 10-foot interval topography converted from 3 meter West Virginia GIS Technical Center DEM data. Stream locations were mapped by AllStar Ecology, LLC. This topographic information and stream data were utilized for the base mapping.

B.3. Hydrologic Analysis

The hydrologic analysis utilized USDA soil surveys for computation of drainage shed curve numbers, aerial topography and 3 meter West Virginia GIS Technical Center DEM to determine the drainage area(s) and time of concentration path(s). The peak 100-year discharge within the inundation area was determined through TR-55 SCS methodology. Time of concentration paths were calculated utilizing the SCS lag method. The hydrologic calculations for the drainage area were performed using HEC-HMS. The breaches were modeled within HEC-HMS utilizing a reservoir and dam breach scenario. The breaches utilized a specific time trigger, with the time set at the peak hour found at the downstream junction of Toms Fork. With the peak times matching, this created the worst case scenario for downstream drainage sheds. The breach widths and development times were modeled using Froelich's Dam Break Predictor Equations. The calculated peak flows for the upstream sections to downstream sections are found in the *Miscellaneous Attachments and Design Computations*. The table below is a summary of the drainage computations for the breach flows.

Stream	Computed Flow (cfs)	Average Breach Width (ft)	Time of Failure (hrs)
East Breach	437.7	26.5	0.28
West Breach	1104.2	35.7	0.19

The proposed Hinter Heirs North Centralized Freshwater Impoundment will be constructed by a combination of excavation and the construction of fill embankments. The proposed fill embankments will be constructed on the south, east and west sides of the facility. The

impoundment height of the east embankment will be 5 feet, and the west side impoundment height will be 14 feet.

The potential breach from the east embankment of the proposed impoundment would travel in a southeasterly direction for approximately 3,500 feet before flowing into Toms Fork. The potential breach from the west embankment of the proposed impoundment would travel in a southwesterly direction for approximately 2,300 feet before flowing into Carder Camp Run.

B.4. Hydraulic Analysis

HEC-RAS was used to analyze the downstream flood wave and model the potential impoundment breach. The base map data was utilized to generate the geometry of each cross section. The cross sections were employed at significant changes in site features. This includes major bends in the stream channel, areas of major contraction and expansion of the floodplain area, upstream and downstream of existing culverts, and at building obstructions (cross sections were compiled using Aerial Mapping by Blue Mountain Aerial Mapping). The Overall Site Map (Appendix A) depicts the locations of the critical sections used for the breach study.

A Steady flow analysis was utilized to model the flood wave, and calculate base flood elevations at critical determined cross sections downstream of the breach analysis based upon Hydrologic Data from HEC-HMS. Downstream reach boundary conditions were modeled utilizing the slope of the normal water surface. The proposed site is located in Flood Zone X per FEMA Flood Map #54017C0250C. Two models were prepared: 1. 100 Year-24 Hour Design Storm, 2. 100 Year-24 Hour Design Storm with Breach. The breach flows were modeled in flow change locations. Breach flows were determined using manning's equation, with maximum volumes generated at the incised volume of the breach location. See the *Miscellaneous Attachments and Design Computations* for complete Drainage Computations.

The channel and overbank areas were assigned manning's n-values based on photographs and close inspection of existing aerial photography. The chart below describes the manning's n values used in this study taken from Table 3-1 of the HEC-RAS River Analysis System Hydraulic Reference Manual Version 4.1, January 2010.

Manning's n value	Description	Portion Used
.1	Heavy stand of timber, few down trees, little undergrowth, flow below branches	Floodplains
.035	Clean, straight, full, no rifts or deep pools with more stones and weeds	Main Channel
.04	Clean, winding, some pools and shoals	Main Channel
.035	High grass	Floodplains
.06	Light brush and trees, in summer	Floodplains
.05	Scattered brush, heavy weeds	Floodplains

B.5. Results

A summary of the hydrologic and hydraulic calculations is provided in the *Miscellaneous Attachments and Design Computations*. Further information from the HEC-RAS or HEC-HMS analysis can be provided upon request.

Section C - Results

C.1. 100 year/24 hour Design Storm Routing

During the 100-year/24-hour design storm, flooding is expected to roads along the drainage shed. County Route 18/16 in the study area is inundated between sections 28+06 and 26+80. Flooding also occurs to County Route 18 between sections 15+65 and -6+30. There is no flooding expected to structures in the design model. The proposed drainage model is located in Flood Zone X per FEMA Flood Map #54017C0250C

C.2. 100 year/24 hour Design Storm Routing with Breach

Additional flooding is expected to roads and bridges during the 100-year/24-hour design storm with an impoundment breach. County Routes 18/16 and 18 are already inundated in the 100-year/24-hour design, however the bridge at the intersection of County Routes 18/16 and 18 will be fully inundated with a western breach to the impoundment, see Part VI for necessary road closure measures and signage required in the case of a breach in the impoundment.

C.3. Summary of Results

For each of the evaluated scenarios the summary of results included with the *Miscellaneous Attachments and Design Computations* provides the following information:

- Peak water surface elevations for the West Breach at Section 10+88 at the intersection of County Routes 18/16 and 18 and at Section 26+10 for the East Breach;

Based on the results of the analysis, flooding on County Route 18/16 will occur under the 100 year flood scenario near stations 28+06 to 26+80 and to County Route 18 near stations 15+65 to -6+30. Water surface elevations will raise across Routes 18/16 and 18 with breach flows. A summary table of the hydrologic and hydraulic calculations is provided in the *Miscellaneous Attachments and Design Computations*.

C.4. Reach Length Analysis

The HEC-RAS summary results provide the WSEs at the critical downstream sections resulting from the various scenarios that were evaluated. Comparing the results of the no breach versus impoundment breach scenarios for the 100-year storm, the resulting WSE in section -18+44 of Toms Fork is less than 1-foot of elevation between the 100-year/24-hour design and the breach scenarios . Therefore, the stations represent the downstream terminus of the flood wave routing, and any further downstream impacts from the breach are a negligible threat to human health or the environment.

PART VI – EVACUATION PLAN AND PROCEDURES

The results of this analysis are based on the "worst case scenario" for the breach events, or the 100 year/24 hour Design Storm Routing with Breach. All breach events that occur in **any** event less than that of the aforementioned design are required to follow the same procedures set forth in the sections below.

Section A – Evacuation Plan

Based on the results of the analysis, no additional flooding is expected to any structures located within the drainage study.

Section B – Road Closure Procedures

Based on the results of the analysis, flooding on County Routes 18/16 and 18 will occur under the 100-year/24-hour design scenario and flood waters already inundate the route along the breach route, the additional breach flows will only further inundate the roadway. The road will be closed with detour routes as shown in the Road Closure and Detour Plans found in Appendix C.

All traffic control devices shall be placed in accordance with the West Virginia Manual on Temporary Traffic Control for Streets and Highways, March 2006. The closure of Co. Rt. 25 and 48 shall only occur after authorization by West Virginia Department of Highways. A WVDOH representative shall be onsite during closure activities. All signage along the detour route shall be in accordance with the West Virginia Manual on Temporary Traffic Control for Streets and Highways, March 2006. A WVDOH representative may require other traffic control signs as necessary.

APPENDICES

Appendix A - Site Maps



NAVITUS
ENGINEERING INC.

151 Wicks Hill Lane
Winchester, Virginia 22602
Telephone: (888) 662-4185
www.naviteeng.com

Engineering Survey Environmental GIS



ANTERO
RESOURCES

THIS DOCUMENT
WAS PREPARED
FOR:
ANTERO RESOURCES
APPALACHIAN CORP.

OVERALL
SITE MAP

HINTER HEIRS
NORTH CENTRALIZED
FRESHWATER IMPOUNDMENT
NEW MILTON DISTRICT
DODDRIDGE COUNTY, WV

SCALE: 1" = 500'

HINTER HEIRS
JOB NO. ANT028



DATE: 05/31/2013

SHEET A.1

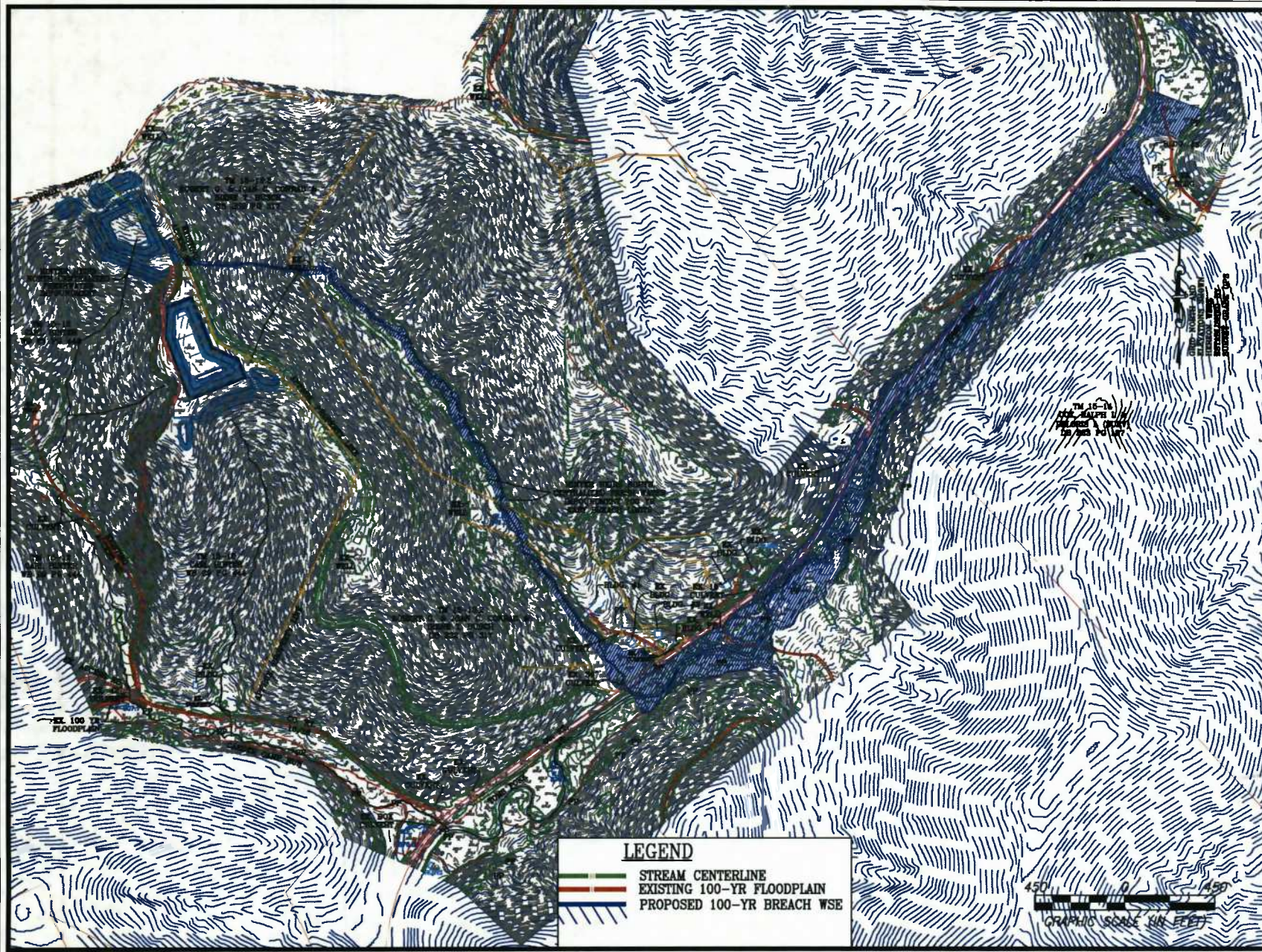



LEGEND

-  STREAM CENTERLINE
-  EXISTING 100-YR FLOODPLAIN
-  PROPOSED 100-YR BREACH WSE



NAVITUS ENGINEERING INC.

151 W. Maple Hill Lane
Martinsburg, WV 26040
Telephone: (304) 662-4185
www.navituseng.com

Engineering Survey Environmental GIS

CYRUS S. KING
REGISTERED
1978
STATE OF
WEST VIRGINIA
PROFESSIONAL ENGINEER

05/31/2013

ANTERO RESOURCES

THIS DOCUMENT WAS PREPARED FOR:

ANTERO RESOURCES
APPALACHIAN CORP



SITE MAP
EAST BREACH
HINTER HEIRS
NORTH CENTRALIZED
FRESHWATER IMPOUNDMENT
NEW MILTON DISTRICT
DODDRIDGE COUNTY, WV

SCALE: 1" = 450'

HINTER HEIRS
JOB NO. ANT028
DATE: 05/31/2013
SHEET A.2



LEGEND

-  STREAM CENTERLINE
-  EXISTING 100-YR FLOODPLAIN
-  PROPOSED 100-YR BREACH WSE



NAVITUS
ENGINEERING INC.

151 Woody Hill Lane
Martinsburg, WV 26002
Telephone: (800) 462-4185
www.navituseng.com

Engineering Survey Environmental GIS



ANTERO RESOURCES

THIS DOCUMENT
WAS PREPARED
FOR:

ANTERO RESOURCES
APPALACHIAN CORP

SITE MAP
WEST BREACH
HINTER HEIRS
NORTH CENTRALIZED
FRESHWATER IMPOUNDMENT
NEW MILTON DISTRICT
DODDRIDGE COUNTY, WV

SCALE: 1" = 450'
HINTER HEIRS JOB NO. ANT028
DATE: 05/31/2013
SHEET A.3

FIRM MAP EXHIBIT



GRID NORTH AND ELEVATIONS ESTABLISHED BY SURVEY GRADE CENS

STOCKPILES
HINTER HEIRS NORTH CENTRALIZED FRESHWATER IMPOUNDMENT

ACCESS ROAD
STOCKPILE
STOCKPILE

FLOODPLAIN NOTE
THE PROPOSED SITE IS LOCATED IN FLOOD ZONE "X" PER FEMA FLOOD MAP #64017C0250C.

NFIP PANEL 0230C

FIRM
FLOOD INSURANCE RATE MAP
DODDRIDGE COUNTY,
WEST VIRGINIA
AND INCORPORATED AREAS

PANEL 230 OF 325
(SEE MAP INDEX FOR FIRM PANEL LAYOUT)

CONTAINS:
COMMUNITY NUMBER PANEL SUFFIX
DODDRIDGE COUNTY 540224 0230 C

Notice to User: The Map Number shown below should be used when placing map orders; the Community Number shown above should be used on insurance applications for the subject community.

MAP NUMBER 54017C0230C
MAP REVISED OCTOBER 4, 2011
Federal Emergency Management Agency

NFIP PANEL 0250C

FIRM
FLOOD INSURANCE RATE MAP
DODDRIDGE COUNTY,
WEST VIRGINIA
AND INCORPORATED AREAS

PANEL 250 OF 325
(SEE MAP INDEX FOR FIRM PANEL LAYOUT)

CONTAINS:
COMMUNITY NUMBER PANEL SUFFIX
DODDRIDGE COUNTY 540224 0250 C

Notice to User: The Map Number shown below should be used when placing map orders; the Community Number shown above should be used on insurance applications for the subject community.

MAP NUMBER 54017C0250C
MAP REVISED OCTOBER 4, 2011
Federal Emergency Management Agency

Engineering Survey Environmental GIS

NAVITUS ENGINEERING INC.
151 Windy Hill Lane
Martinsburg, WV 26402
Tel: 304-293-1185
www.navituseng.com

REVISION	DATE

ANTERO RESOURCES
THIS DOCUMENT WAS PREPARED FOR:
ANTERO RESOURCES
APPALACHIAN CORP

FIRM MAP EXHIBIT
HINTER HEIRS NORTH
NEW MILTON DISTRICT
DODDRIDGE COUNTY, WEST VIRGINIA

DATE: 06/14/2013
SCALE: 1" = 500'
SHEET 1 OF 1

CONSTRUCTION AND E&S CONTROL NOTES

CONSTRUCTION NOTES:

1. THE CONTRACTOR IS TO VERIFY FIELD CONDITIONS PRIOR TO AND DURING CONSTRUCTION AND WILL NOTIFY NAVITUS ENGINEERING AT (888) 662-4185 IMMEDIATELY OF ANY DISCREPANCIES BETWEEN ACTUAL FIELD CONDITIONS AND THE APPROVED PLAN. ANY WORK PERFORMED BY THE CONTRACTOR AFTER THE FINDING OF SUCH DISCREPANCIES, SHALL BE DONE AT THE CONTRACTOR'S RISK.
2. METHODS AND MATERIALS USED IN THE CONSTRUCTION OF THE IMPROVEMENTS HEREIN SHALL CONFORM TO THE CURRENT COUNTY CONSTRUCTION STANDARDS AND SPECIFICATIONS AND/OR CURRENT WV DEP EROSION AND SEDIMENT CONTROL BEST MANAGEMENT PRACTICE MANUAL STANDARDS AND SPECIFICATIONS. SHOULD A CONFLICT BETWEEN THE DESIGN, SPECIFICATIONS, AND PLANS OCCUR, THE MOST STRINGENT REQUIREMENT WILL APPLY. THE APPROVAL OF THESE PLANS IN NO WAY RELIEVES THE DEVELOPER OR HIS AGENT OF THE RESPONSIBILITIES CONTAINED IN THE WV DEP EROSION AND SEDIMENT CONTROL BEST MANAGEMENT PRACTICE MANUAL.
3. AN APPROVED SET OF PLANS AND ALL APPLICABLE PERMITS MUST BE AVAILABLE AT THE CONSTRUCTION SITE. ALSO, A REPRESENTATIVE OF THE DEVELOPER MUST BE AVAILABLE AT ALL TIMES.
4. THE CONTRACTOR SHALL PROVIDE ADEQUATE MEANS OF CLEANING MUD FROM TRUCKS AND/OR OTHER EQUIPMENT PRIOR TO ENTERING PUBLIC STREETS, AND IT IS THE CONTRACTOR'S RESPONSIBILITY TO CLEAN STREETS, ALLAY DUST, AND TO TAKE WHATEVER MEASURES ARE NECESSARY TO INSURE THAT THE STREETS ARE MAINTAINED IN A CLEAN, MUD AND DUST FREE CONDITION AT ALL TIMES.
5. THE LOCATION OF EXISTING UTILITIES SHOWN IN THESE PLANS ARE FROM FIELD LOCATIONS. IT SHALL BE THE CONTRACTOR'S RESPONSIBILITY TO VERIFY THE EXACT HORIZONTAL AND VERTICAL LOCATION OF ALL EXISTING UTILITIES AS NEEDED PRIOR TO CONSTRUCTION. THE CONTRACTOR SHALL INFORM THE ENGINEER OF ANY CONFLICTS ARISING FROM HIS EXISTING UTILITY VERIFICATION AND THE PROPOSED CONSTRUCTION.
6. THE CONTRACTOR SHALL PROVIDE NOTIFICATION TO THE APPROPRIATE UTILITY COMPANY PRIOR TO CONSTRUCTION OF WATER AND/OR GAS PIPE LINES. INFORMATION SHOULD ALSO BE OBTAINED FROM THE APPROPRIATE AUTHORITY CONCERNING PERMITS, CUT SHEETS, AND CONNECTIONS TO EXISTING LINES.
7. THE CONTRACTOR WILL BE RESPONSIBLE FOR THE REPAIR OF ANY DAMAGES TO THE EXISTING STREETS AND UTILITIES WHICH OCCURS AS A RESULT OF HIS CONSTRUCTION PROJECT WITHIN OR CONTIGUOUS TO THE EXISTING RIGHT-OF-WAY.
8. WHEN GRADING IS PROPOSED WITHIN EASEMENTS OF UTILITIES, LETTERS OF PERMISSION FROM ALL INVOLVED COMPANIES MUST BE OBTAINED PRIOR TO GRADING AND/OR SITE DEVELOPMENT.
9. THE DEVELOPER WILL BE RESPONSIBLE FOR THE RELOCATION OF ANY UTILITIES WHICH IS REQUIRED AS A RESULT OF HIS PROJECT. THE RELOCATION SHOULD BE DONE PRIOR TO CONSTRUCTION.
10. THESE PLANS IDENTIFY THE LOCATION OF ALL KNOWN GRAVESITES. GRAVESITES SHOWN ON THIS PLAN WILL BE PROTECTED IN ACCORDANCE WITH STATE LAW. IN THE EVENT GRAVESITES ARE DISCOVERED DURING CONSTRUCTION, THE OWNER AND ENGINEER MUST BE NOTIFIED IMMEDIATELY.
11. THE CONTRACTOR(S) SHALL NOTIFY OPERATORS WHO MAINTAIN UNDERGROUND UTILITY LINES IN THE AREA OF PROPOSED EXCAVATING OR BLASTING AT LEAST TWO (2) WORKING DAYS, BUT NOT MORE THAN TEN (10) WORKING DAYS, PRIOR TO COMMENCEMENT OF EXCAVATION OR DEMOLITION.
12. CONTRACTOR TO CONTACT OPERATOR AND ENGINEER IF GROUNDWATER IS ENCOUNTERED DURING CONSTRUCTION.
13. THE CONTRACTOR SHALL SCHEDULE A PRE-CONSTRUCTION MEETING WITH THE EROSION AND SEDIMENT CONTROL INSPECTOR, 2 DAYS PRIOR TO THE START OF CONSTRUCTION.
14. THE CONTRACTOR IS RESPONSIBLE FOR ALL FILL MATERIAL TESTING REQUIRED DURING THE CONSTRUCTION OF THIS PROJECT. ALL MATERIAL TEST SHALL BE CONDUCTED BY A CERTIFIED MATERIALS TESTING LABORATORY AND A CERTIFICATION OF THE MATERIALS TESTED SHALL BE PROVIDED BY A LICENSED PROFESSIONAL ENGINEER REPRESENTING THE LABORATORY. ALL TEST RESULTS SHALL BE SUBMITTED TO THE ENGINEER CERTIFYING THE CONSTRUCTED FACILITY. FAILURE TO CONDUCT THE DENSITY TEST SHALL BE CAUSE FOR NON-ACCEPTANCE OF THE CONSTRUCTED FACILITY.
15. THE CONTRACTOR IS RESPONSIBLE FOR CONSTRUCTING THE SITE IN ACCORDANCE WITH THE DESIGN PLANS AND CONSTRUCTION DOCUMENTS AND THE SCOPE OF WORK SHALL CONFORM WITH THE GRADES, BERMS, DEPTHS, DIMENSIONS, ETC. SHOWN HEREON.

SITE CLEANUP & RECYCLE PROGRAM

1. GARBAGE, FUELS OR ANY SUBSTANCE HARMFUL TO HUMAN, AQUATIC OR FISH LIFE, WILL BE PREVENTED FROM ENTERING SPRINGS, STREAMS, PONDS, LAKES, WETLANDS OR ANY WATER COURSE OR WATER BODY.
2. OILS, FUELS, LUBRICANTS AND COOLANTS WILL BE PLACED IN SUITABLE CONTAINERS AND DISPOSED PROPERLY.
3. ALL TRASH AND GARBAGE WILL BE COLLECTED AND DISPOSED PROPERLY.
4. ALL SEDIMENT REMOVED FROM SEDIMENT CAPTURING DEVICES SHALL BE PLACED ON THE TOPSOIL STOCKPILE, THEN SEEDED AND MULCHED, AS NECESSARY. ALTERNATIVELY, THE REMOVED SEDIMENT CAN BE TRANSPORTED TO A SITE WITH AN APPROVED PERMIT.
5. ALL POLLUTION AND EMERGENCY SPILLS SHALL BE IMMEDIATELY REPORTED TO THE WVDEP OFFICE OF OIL AND GAS. (EMERGENCY #1-800-842-3074).

EROSION AND SEDIMENT CONTROL NARRATIVE

PROJECT DESCRIPTION: THE PURPOSE OF THIS PROJECT IS TO CONSTRUCT A CENTRALIZED FRESHWATER IMPOUNDMENT TO AID IN THE DEVELOPMENT OF INDIVIDUAL GAS WELLS. THE ACCESS ROAD TO THE PROPOSED SITE IS LOCATED ON THE NORTH SIDE OF CO RT. 18/16, 0.33 MILES WEST OF THE INTERSECTION OF CO RT. 18/16 & CO. RT. 18 IN NEW MILTON DISTRICT, DODDRIDGE COUNTY, WEST VIRGINIA. THE TOTAL APPROXIMATE LAND DISTURBANCE ASSOCIATED WITH THIS PROJECT IS 4.97 ACRES.

EXISTING SITE CONDITIONS: THE EXISTING SITE IS COMPLETELY FORESTED. THE TOPOGRAPHY RANGES FROM MODERATE TO STEEP TERRAIN (2% TO 60% SLOPES). PRESENT ON SITE ARE THREE EXISTING GAS WELLS AND ONE EXISTING GAS PIPELINE. ALSO PRESENT ARE ACCESS ROADS, STRUCTURES, OVERHEAD UTILITIES, ONE PERENNIAL STREAM, TEN EPHEMERAL STREAMS AND ONE INTERMITTENT STREAM. THE SITE IS LOCATED ON A RIDGE AND DRAINS TO TOM'S FORK.

ADJACENT PROPERTY: THE SITE IS BORDERED BY FORESTED LANDS ON ALL SIDES. NEARBY STREAMS INCLUDE GARDER CAMP RUN TO THE SOUTH AND TOMS FORK TO THE SOUTHWEST. THE SITE IS BORDERED BY CO RT. 18/16 TO THE SOUTH (LOCATION OF ACCESS ROAD ENTRANCE).

CRITICAL AREAS: THE AREA(S) SHOWN ALONG THE FIELD DELINEATED STREAMS, WETLANDS, AND PONDS, AS SHOWN ON THE PLANS, ARE DESIGNATED AS CRITICAL AREA(S), IF PRESENT. COMPOST FILTER SOCKS ARE TO BE USED TO PROTECT THESE FIELD DELINEATED AREA(S) FROM SEDIMENT LEAVING THE SITE. ADDITIONALLY, ORANGE SAFETY FENCE IS RECOMMENDED TO BE INSTALLED ABOVE/AROUND THESE AREA(S), TO SERVE AS A PHYSICAL BARRIER, ENSURING THE AREA(S) ARE NOT DISTURBED.

SOILS: A SUBSURFACE INVESTIGATION OF THE PROPOSED SITE WAS PERFORMED BY G.A. COVEY ENGINEERING, PLLC ON DECEMBER 17, 18, & 19, 2012. THE REPORT PREPARED BY G.A. COVEY ENGINEERING, PLLC, DATED JANUARY, 2013, REFLECTS THE RESULTS OF THE SUBSURFACE INVESTIGATION. THE INFORMATION AND RECOMMENDATIONS CONTAINED IN THIS REPORT WAS USED IN THE PREPARATION OF THESE PLANS. PLEASE REFER TO THE SUBSURFACE INVESTIGATION REPORT BY G.A. COVEY ENGINEERING, PLLC FOR ADDITIONAL INFORMATION, AS NEEDED.

OFF SITE AREAS: THERE ARE NO BORROW AREA(S) OR EXPORT STOCKPILE AREA(S) OUTSIDE OF THE PROPOSED LIMITS OF DISTURBANCE FOR THIS PROJECT.

EROSION AND SEDIMENT CONTROL MEASURES: UNLESS OTHERWISE INDICATED, ALL VEGETATIVE AND STRUCTURAL EROSION AND SEDIMENT CONTROL MEASURES SHALL BE CONSTRUCTED AND MAINTAINED ACCORDING TO MINIMUM STANDARDS AND SPECIFICATIONS OF THE CURRENT WEST VIRGINIA EROSION AND SEDIMENT CONTROL BEST MANAGEMENT PRACTICE MANUAL.

STRUCTURAL PRACTICES:

PHASE I:

1. INSTALL ORANGE SAFETY FENCE TO ENSURE NO DISTURBANCE TO THE DELINEATED AREA(S)
2. INSTALL TEMPORARY CONSTRUCTION ENTRANCE.
3. INSTALL COMPOST FILTER SOCKS AS SHOWN ON THE PLANS AS PHASE 1 CONTROL MEASURES TO REMOVE SEDIMENT FROM RUNOFF. SELECTIVELY REMOVE TREES REQUIRED TO INSTALL COMPOST FILTER SOCK IN WOODED AREAS. CLEARING AND GRUBBING SHALL BE KEPT AT A MINIMUM TO INSTALL E&S CONTROLS.
4. EROSION CONTROL BLANKETS SHALL BE PLACED ON ALL CRITICAL SLOPES (3:1 OR GREATER) AND AS NEEDED TO STABILIZE DISTURBED AREAS.

PHASE II:

1. ALL CONTROLS INSTALLED IN PHASE I SHALL REMAIN FOR THE DURATION OF THE PROJECT.
2. FILL SLOPE SURFACE SHALL BE LEFT IN A ROUGHENED CONDITION TO REDUCE EROSION. CONTRACTOR SHALL REDIRECT RUNOFF AWAY FROM THE FILL SLOPE BY INSTALLING EARTHEN DIVERSION BERMS AND DIVERTING THE RUNOFF TO SEDIMENT TRAPPING DEVICES.
3. INSTALL V-DITCHES, DITCH RELIEF CULVERTS, AND OUTLET PROTECTION (RIP-RAP APRONS) AS SHOWN ON THE PLANS.
4. EROSION CONTROL BLANKETS SHALL BE PLACED ON ALL CRITICAL SLOPES (3:1 OR GREATER) AND AS NEEDED TO STABILIZE DISTURBED AREAS.

DEVICES LISTED ABOVE ARE CONSIDERED MINIMUM EROSION AND SEDIMENT CONTROLS. ADDITIONAL CONTROL MEASURES MAY BE NECESSARY DUE TO CONTRACTOR PHASING OR OTHER UNFORESEEN CONDITIONS. IMMEDIATELY UPON DISCOVERING UNFORESEEN CIRCUMSTANCES POSING THE POTENTIAL FOR ACCELERATED EROSION AND/OR SEDIMENT POLLUTION, THE CONTRACTOR SHALL IMPLEMENT APPROPRIATE BMP'S TO MINIMIZE THE POTENTIAL FOR EROSION AND SEDIMENT POLLUTION. ALL MEASURES SHALL BE CONSTRUCTED AND MAINTAINED ACCORDING TO MINIMUM STANDARDS AND SPECIFICATIONS OF THE CURRENT WEST VIRGINIA EROSION AND SEDIMENT CONTROL BEST MANAGEMENT PRACTICE MANUAL.

MAINTENANCE PROGRAM:

ALL CONTROL MEASURES SHALL BE INSPECTED DAILY BY THE SITE SUPERINTENDENT OR HIS REPRESENTATIVE AND WITHIN 24 HOURS AFTER ANY RUNOFF EVENT. ANY DAMAGED STRUCTURAL MEASURES ARE TO BE REPAIRED, BY THE END OF THE DAY, OR AT THE EARLIEST TIME IN WHICH IT IS SAFE TO DO SO. SEEDING AREAS SHALL BE CHECKED REGULARLY TO ENSURE THAT A GOOD STAND OF GRASS IS MAINTAINED. ALL AREAS SHALL BE FERTILIZED AND RESEEDED AS NEEDED UNTIL GRASS IS ESTABLISHED.

TRAPPED SEDIMENT IS TO BE REMOVED AS REQUIRED TO MAINTAIN 60% TRAP AND/OR SOCK EFFICIENCY AND DISPOSED OF BY SPREADING ON THE STOCKPILE.

INLET OF DITCH RELIEF CULVERTS SHALL BE CHECKED REGULARLY FOR SEDIMENT BUILD-UP. IF THE GRAVEL OUTLET IS CLOGGED BY SEDIMENT, IT SHALL BE REMOVED AND CLEANED OR REPLACED IMMEDIATELY.

SEDIMENT TRACKED ONTO ANY PUBLIC ROADWAY OR SIDEWALK SHALL BE RETURNED TO THE CONSTRUCTION SITE BY THE END OF EACH WORK DAY AND DISPOSED IN THE MANNER DESCRIBED IN THIS PLAN. IN NO CASE SHALL THE SEDIMENT BE WASHED, SHOVELED OR SWEEPED INTO ANY ROADSIDE DITCH, CULVERT OR SURFACE WATER.

ANY DISTURBED AREAS ALONG THE ACCESS ROAD SHALL BE STABILIZED PRIOR TO THE END OF EACH DAY WITH EITHER ROCK STABILIZATION OR SEEDING AND MULCHING METHODS.

NOTE: THE WV DEP RETAINS THE RIGHT TO ADD AND/OR MODIFY THESE EROSION AND SEDIMENT CONTROL MEASURES DURING THE CONSTRUCTION PROCESS, WITHIN REASON, TO ENSURE ADEQUATE PROTECTION TO THE PUBLIC AND THE ENVIRONMENT.

SEEDING (SOIL STABILIZATION):

1. CONTRACTOR SHALL APPLY SEED AND STABILIZATION IN ACCORDANCE WITH THE WV DEP EROSION AND SEDIMENT CONTROL BEST MANAGEMENT PRACTICE (BMP) MANUAL, BASED UPON SITE SPECIFIC SOIL CHARACTERISTICS.
2. WHEREVER SEEDING IS TO BE APPLIED TO STEEP SLOPES (> 3H:1V), SEED MIXTURES SHOULD BE SELECTED THAT ARE APPROPRIATE FOR STEEP SLOPES.

DUST CONTROL:

1. TEMPORARY SEEDING SHALL BE APPLIED TO ALL DISTURBED AREAS SUBJECT TO LITTLE OR NO CONSTRUCTION TRAFFIC.
2. ALL HAUL ROADS AND OTHER HEAVY TRAFFIC ROUTES SHALL BE SPRINKLED WITH WATER UNTIL THE SURFACE IS WET AND REPEATED AS NEEDED TO CONTROL DUST.

CONSTRUCTION SEQUENCE

THE DEVELOPMENT OF THIS SITE SHALL BE CONSISTENT WITH THE FOLLOWING GENERAL SEQUENCE OF CONSTRUCTION. THE CONTRACTOR SHALL IMPLEMENT, MAINTAIN, AND OPERATE ALL PROPOSED EROSION AND SEDIMENT CONTROL MEASURES TO EFFECTIVELY MITIGATE THE HAZARD OF ACCELERATED EROSION AND SEDIMENTATION TO ACCEPTABLE LEVELS. MINOR DEVIATIONS FROM THIS SEQUENCE SHALL BE EXECUTED BY THE PROJECT'S SUPERINTENDENT AS NEEDED TO ELIMINATE ANY POTENTIAL EROSION CONDITION THAT MAY ARISE FOR THE DURATION OF THE PROJECT. THE WV DEP OFFICE OF OIL AND GAS SHALL BE NOTIFIED OF ANY AND ALL SUCH DEVIATIONS FROM THE APPROVED PLANS.

1. A PRE-CONSTRUCTION CONFERENCE WITH THE CONTRACTOR AND THE APPROPRIATE EROSION AND SEDIMENT CONTROL INSPECTOR 48 HOURS PRIOR TO BEGINNING WORK TO REVIEW THE CONSTRUCTION DRAWINGS AND PROVIDE ANY REQUESTED GUIDANCE.
2. STAKE THE LIMITS OF CONSTRUCTION AND MARK ALL IDENTIFIED WETLANDS, STREAMS, AND OTHER AREAS OF CONCERN FOR CONSTRUCTION ACTIVITIES.
3. CONSTRUCT THE ROCK CONSTRUCTION ENTRANCE. ALL VEHICLES ENTERING AND EXITING THE SITE SHALL DO SO VIA THE ROCK CONSTRUCTION ENTRANCE.
4. CONSTRUCT ALL BMP'S AS SOON AS CLEARING AND GRUBBING OPERATIONS ALLOW. DIVERSIONS AND SEDIMENT TRAP(S)/BASIN(S) SHALL BE SEEDED AND MULCHED IMMEDIATELY.
5. IF APPLICABLE, CONVEY UPSLOPE DRAINAGE AROUND THE ACCESS ROAD AND PAD/PIT AREA BY CONSTRUCTING ALL DIVERSION BERM(S) AND/OR COMPOST FILTER SOCK DIVERSION(S) AS SHOWN ON THE PLANS.
6. CLEAR AND GRUB THE SITE. ALL WOODY MATERIAL, BRUSH, TREES, STUMPS, LARGE ROOTS, BOULDERS, AND DEBRIS SHALL BE CLEARED FROM THE SITE AREA AND KEPT TO THE MINIMUM NECESSARY FOR PROPER CONSTRUCTION, INCLUDING THE INSTALLATION OF NECESSARY SEDIMENT CONTROLS. TREES SIX INCHES IN DIAMETER AND LARGER SHALL BE CUT AND LOGS STACKED. SMALLER TREES, BRUSH, & STUMPS SHALL BE CUT AND/OR GRUBBED AND WINDOWN IN APPROPRIATE AREAS FOR USE AS BRUSH PILE SEDIMENT BARRIERS (AS SHOWN ON THE PLANS); WILDLIFE HABITATS, BURNED (AS PER WV FOREST FIRE LAWS), REMOVED FROM SITE, OR DISPOSED OF BY OTHER METHODS APPROVED BY WV DEP.
7. IF APPLICABLE, INSTALL ALL WETLAND OR STREAM CROSSINGS AS SHOWN ON THE PLANS.
8. STRIP THE TOPSOIL FROM THE ACCESS ROAD. ALL STRIPPED TOPSOIL SHALL BE STOCKPILED IN AREAS SHOWN IN THE PLANS AND IMMEDIATELY STABILIZED. ADDITIONAL BMP MEASURES SHALL BE CONSTRUCTED AROUND TOPSOIL STOCKPILES, IF NECESSARY.
9. CONSTRUCT THE ACCESS ROAD. DITCH RELIEF CULVERTS SHALL BE INSTALLED AT A GRADE OF 1-8% TO MINIMIZE OUTLET VELOCITIES TO THE EXTENT POSSIBLE. INSTALL OUTLET PROTECTION ONCE DITCH RELIEF CULVERTS ARE INSTALLED, AS SHOWN ON PLANS. STABILIZE THE ROAD WITH GEOTEXTILE FABRIC & STONE AND SIDE SLOPES AS SPECIFIED WITH PERMANENT SEEDING. EXCESS MATERIAL SHALL BE STOCKPILED (IF NECESSARY) IN AREAS SHOWN IN THE PLANS AND IMMEDIATELY STABILIZED. ALL DITCH LINES SHALL BE CLEARED PRIOR TO INSTALLATION OF LINED PROTECTION.
10. STRIP THE TOPSOIL FROM THE CENTRALIZED FRESHWATER IMPOUNDMENT AREA. ALL STRIPPED TOPSOIL SHALL BE STOCKPILED IN AREAS SHOWN IN THE PLANS AND IMMEDIATELY STABILIZED. ADDITIONAL BMP MEASURES SHALL BE CONSTRUCTED AROUND TOPSOIL STOCKPILES, IF NECESSARY.
11. GRADE THE CENTRALIZED FRESHWATER IMPOUNDMENT AREA AS SHOWN ON THE PLANS. ALL FILL AREAS SHALL BE "KEYED IN" AND COMPACTED IN HORIZONTAL LIFTS WITH A MAXIMUM LOOSE LIFT THICKNESS OF 9" AND MAXIMUM PARTICLE SIZE OF LESS THAN 6". ALL FILL SHALL BE COMPACTED BY A VIBRATING SHEEPSFOOT ROLLER TO 95% PER THE STANDARD PROCTOR TEST (ASTM-D698).
12. IMMEDIATELY STABILIZE THE OUTER AREAS OF THE CENTRALIZED FRESHWATER IMPOUNDMENT AND TURNAROUND PAD(S). THE TURNAROUND PAD(S) SHALL BE STABILIZED WITH GEOTEXTILE FABRIC & STONE AND THE SIDE SLOPES WITH EROSION CONTROL BLANKETING WHEN SLOPES ARE 3:1 OR GREATER. APPLY SEED AND MULCH TO ALL DISTURBED AREAS. THIS SHALL INCLUDE ALL AREAS THAT WILL NOT BE SUBJECT TO REGULAR TRAFFIC ACTIVITY (TO BE STABILIZED WITH STONE) OR ANY DISTURBED AREA THAT WILL NOT BE RE-DISTURBED BEFORE SITE RECLAMATION BEGINS.
13. PRIOR TO THE INSTALLATION OF THE CENTRALIZED FRESHWATER IMPOUNDMENT LINER SYSTEM, THE CONTRACTOR SHALL CONTACT THE ENGINEER/SURVEYOR TO COMPLETE AN AS-BUILT SURVEY OF THE CONSTRUCTED CENTRALIZED FRESHWATER IMPOUNDMENT TO ENSURE CONFORMANCE WITH THE DESIGN DRAWINGS. THE AS-BUILT WILL BE REVIEWED BY THE ENGINEER AND THE CONTRACTOR IS RESPONSIBLE FOR ANY CORRECTIVE ACTION DEEMED NECESSARY BY THE ENGINEER FOR ANY DEVIATION(S) FROM THE DESIGN DRAWINGS.
14. INSTALL THE CENTRALIZED FRESHWATER IMPOUNDMENT LINER SYSTEM AND PERIMETER SAFETY FENCE W/GATE AND EMERGENCY LIFE LINE AS SHOWN ON THE PLANS. SEE DETAILS FOR ADDITIONAL INFORMATION.
15. ONCE THE CENTRALIZED FRESHWATER IMPOUNDMENT HAS BEEN COMPLETED, SUBMIT THE AS-BUILT CERTIFICATION FOR THE CENTRALIZED FRESHWATER IMPOUNDMENT FACILITY TO THE WV DEP OFFICE OF OIL AND GAS, PRIOR TO PLACING FLUIDS IN THE STRUCTURE.
16. COMMENCE USE OF THE CENTRALIZED FRESHWATER IMPOUNDMENT FACILITY.
17. ALL BMP'S MUST REMAIN IN PLACE AND FUNCTIONAL UNTIL ALL AREAS WITHIN THE LIMIT OF DISTURBANCE ARE COMPLETE AND PERMANENTLY STABILIZED. MAINTENANCE MUST INCLUDE INSPECTION OF ALL EROSION AND SEDIMENT CONTROLS AFTER EACH RUNOFF EVENT IN EXCESS OF 0.5" AND ON A BIWEEKLY BASIS.
18. THE CONSTRUCTION SITE SHOULD BE STABILIZED AS SOON AS POSSIBLE AFTER COMPLETION. ESTABLISHMENT OF FINAL COVER MUST BE INITIATED NO LATER THAN 7 DAYS AFTER REACHING FINAL GRADE. A NOTICE OF TERMINATION MUST BE FILED WITH THE DEP WHEN THE SITE REACHED FINAL STABILIZATION. FINAL STABILIZATION MEANS THAT ALL SOIL-DISTURBING ACTIVITIES ARE COMPLETED, AND THAT EITHER A PERMANENT VEGETATIVE COVER WITH A DENSITY OF 70% OR GREATER HAS BEEN ESTABLISHED OR THAT THE SURFACE HAS BEEN STABILIZED BY HARD COVER SUCH AS PAVEMENT OR BUILDINGS. IT SHOULD BE NOTED THAT THE 70% REQUIREMENT REFERS TO THE TOTAL AREA VEGETATED AND NOT JUST A PERCENT OF THE SITE.
19. ALL PERMANENT SEDIMENT CONTROL MEASURES CAN BE REMOVED AFTER THE SITE IS PERMANENTLY STABILIZED AND APPROVAL IS RECEIVED FROM THE WVDEP.
20. ANY AREAS DISTURBED BY REMOVAL OF CONTROLS SHALL BE REPAIRED, STABILIZED, AND PERMANENTLY SEEDED.

CENTRALIZED FRESHWATER IMPOUNDMENT CONSTRUCTION STANDARDS

THE DESIGN, CONSTRUCTION, AND REMOVAL OF EMBANKMENTS ASSOCIATED WITH CENTRALIZED FRESHWATER IMPOUNDMENTS FOR OIL AND GAS WELLS MUST BE ACCOMPLISHED IN SUCH A MANNER AS TO PROTECT THE HEALTH AND SAFETY OF THE PEOPLE, THE NATURAL RESOURCES, AND ENVIRONMENT OF THE STATE. THE CENTRALIZED FRESHWATER IMPOUNDMENT EMBANKMENTS SHALL BE DESIGNED, CONSTRUCTED, AND MAINTAINED TO BE STRUCTURALLY SOUND AND REASONABLY PROTECTED FROM UNAUTHORIZED ACTS OF THIRD PARTIES.

1. THE FOUNDATION FOR A CENTRALIZED FRESHWATER IMPOUNDMENT EMBANKMENT MUST BE STRIPPED AND GRUBBED TO SOLID GROUND PRIOR TO THE PLACEMENT AND COMPACTION OF EARTHEN FILL MATERIAL. SHOULD SOLID GROUND NOT BE FOUND WITHIN A DEPTH OF 24", CONTRACTOR WILL NOTIFY NAVITUS ENGINEERING AT (888) 662-4185 IMMEDIATELY. NO EMBANKMENT FILL SHALL CONTAIN OR BE PLACED ON FROZEN MATERIAL.
2. ANY SPRINGS ENCOUNTERED WITHIN THE FOUNDATION AREA SHALL BE DRAINED TO THE OUTSIDE/DOWNSTREAM TOB OF EMBANKMENT. CONSTRUCTED DRAIN SECTION SHALL BE AN EXCAVATED 2' x 2' TRENCH AND BACK FILLED WITH TYPE A SAND, COMPACTED BY HAND TAMPER. NO GEOTEXTILES SHALL BE USED TO LINE TRENCH. THE LAST 3' OF DRAIN AT THE DOWNSTREAM END SHALL BE CONSTRUCTED WITH AASHTO #8 MATERIAL.
3. SOILS FOR EARTHEN EMBANKMENT CONSTRUCTION SHALL BE LIMITED TO TYPES GC, GM, SC, SM, CL, OR ML (ASTM-D2487 UNIFIED SOILS CLASSIFICATION). SOILS MUST CONTAIN A MINIMUM OF 20% PLUS NO. 200 SIEVE AND BE "WELL GRADED" MATERIAL WITH NO COBBLES OR BOULDER SIZE MATERIAL MIXED WITH THE CLAY. A MINIMUM OF THREE SAMPLES SHALL BE CLASSIFIED.
4. ALL FILL AREAS SHALL BE "KEYED IN" AND COMPACTED IN HORIZONTAL LIFTS WITH A MAXIMUM LOOSE LIFT THICKNESS OF 9" AND MAXIMUM PARTICLE SIZE OF LESS THAN 6". ALL FILL SHALL BE COMPACTED BY A VIBRATING SHEEPSFOOT ROLLER TO 95% PER THE STANDARD PROCTOR TEST (ASTM-D698).
5. THE PLACEMENT OF ALL FILL MATERIAL SHALL BE FREE OF WOOD, STUMPS AND ROOTS, LARGE ROCKS AND BOULDERS, AND ANY OTHER NONCOMPACTABLE SOIL MATERIAL. THE EMBANKMENT SHALL BE COMPACTED TO A MINIMUM OF VISIBLE NON-MOVEMENT, HOWEVER, THE COMPACTION EFFORT SHALL NOT EXCEED THE OPTIMUM MOISTURE LIMITS.
6. THE EMBANKMENT TOP SHALL BE A MINIMUM OF 12' IN WIDTH.
7. THE MINIMUM INSIDE AND OUTSIDE EMBANKMENT (FILL) SLOPES SHALL BE 2H:1V, UNLESS OTHERWISE SPECIFIED. THE INSIDE AND OUTSIDE EMBANKMENT (FILL) SLOPES MUST ADD UP TO 5H:1V.
8. ALL EXPOSED EMBANKMENT SLOPES, NOT COVERED BY COMPACTED ROCKFILL OR RIP-RAP SHALL BE LINED, FERTILIZED, SEEDED, AND MULCHED. PERMANENT VEGETATIVE GROUND COVER IN COMPLIANCE WITH THE WV DEP EROSION AND SEDIMENT CONTROL FIELD MANUAL MUST BE ESTABLISHED UPON THE COMPLETION OF THE CENTRALIZED FRESHWATER IMPOUNDMENT CONSTRUCTION. EMBANKMENTS SHALL BE MAINTAINED WITH A GRASSY VEGETATIVE COVER AND FREE OF BRUSH AND/OR TREES.
9. A MINIMUM OF 2' OF FREEBOARD SHALL BE MAINTAINED AT ALL TIMES DURING THE OPERATION OF THE IMPOUNDMENT.
10. ALL EMBANKMENT CONSTRUCTION AND COMPACTION TESTING SHALL BE THE RESPONSIBILITY OF THE CONTRACTOR.

CENTRALIZED FRESHWATER IMPOUNDMENT LINER SYSTEM NOTES

THE DESIGNED CENTRALIZED FRESHWATER IMPOUNDMENT FACILITY SHALL BE FULLY LINED WITH A GEOSYNTHETIC LINER SYSTEM. LINERS SHALL BE INSTALLED IN ACCORDANCE TO MANUFACTURER'S SPECIFICATIONS.

1. THE SUB-BASE SHALL BEAR THE WEIGHT OF THE LINER SYSTEM, WATER, AND EQUIPMENT OPERATING ON THE CENTRALIZED FRESHWATER IMPOUNDMENT WITHOUT CAUSING OR ALLOWING A FAILURE OF THE LINER SYSTEM.
2. THE SUB-BASE SHALL BE COMPACTED TO ACCOMMODATE POTENTIAL SETTLEMENT WITHOUT DAMAGE TO THE LINER SYSTEM.
3. THE UPPER 6" OF THE SUB-BASE SHALL BE COMPACTED TO A STANDARD PROCTOR DENSITY OF AT LEAST 95%.
4. THE SUB-BASE SHALL BE HARD, UNIFORM, SMOOTH AND FREE OF DEBRIS, ROCK FRAGMENTS, PLANT MATERIAL, AND OTHER FOREIGN MATERIAL.
5. THE SUB-BASE SHALL BE COVERED WITH NON-WOVEN GEOTEXTILE FABRIC TO CUSHION THE PRIMARY LINER AND ALLOW FOR ADEQUATE VENTING BETWEEN THE PRIMARY LINER AND THE SUB-BASE TO PREVENT THE ENTRAPMENT OF GASES BENEATH THE LINER SYSTEM.
6. THE CENTRALIZED FRESHWATER IMPOUNDMENT AREA SHALL BE DRAINED AND COMPLETELY DRY PRIOR TO THE PLACEMENT OF THE PRIMARY LINER. THE PRIMARY LINER SHALL MEET ALL WV DEP GUIDELINES FOR MINIMUM THICKNESS AND SHALL PREVENT THE MIGRATION OF WATER THROUGH THE LINER TO THE GREATEST DEGREE THAT IS TECHNOLOGICALLY POSSIBLE.
7. THE PRIMARY LINER SHALL FULLY COVER THE BOTTOM, SIDEWALLS, AND ANCHORING TRENCH OF THE CENTRALIZED FRESHWATER IMPOUNDMENT. A TEXTURED LINER IS RECOMMENDED TO PROVIDE A SAFER WALKING SURFACE.
8. AN ANCHOR TRENCH SHALL BE EXCAVATED COMPLETELY AROUND THE PERIMETER OF THE CENTRALIZED FRESHWATER IMPOUNDMENT AREA AT THE PLANNED ELEVATION OF THE TOP OF THE LINING. THE TRENCH SHALL BE A MINIMUM 36 INCHES DEEP AND 24 INCHES WIDE.
9. ALL ELEMENTS OF THE LINER SYSTEM SHALL BE INSTALLED IN ACCORDANCE WITH THE MANUFACTURER'S SPECIFICATIONS. ALL SEAMS AND SEALS AROUND ANY PROJECTIONS SHALL BE SEALED AND TESTED IN A METHOD APPROVED BY THE MANUFACTURER.
10. GAS RELIEF VENTS SHALL BE PROVIDED ALONG THE TOP OF THE LINER AND WITHIN ONE FOOT OF THE PERIMETER OF THE CENTRALIZED FRESHWATER IMPOUNDMENT TO ALLOW GASES TO ESCAPE FROM UNDER THE GEOMEMBRANE. MAXIMUM SPACING FOR VENTS SHALL BE 30 FEET.
11. WATER LEVEL MARKINGS SHALL BE CLEARLY PAINTED (6" INCREMENTS) ON THE LINER SYSTEM TO IDENTIFY THE WATER SURFACE ELEVATION.

Engineering
Survey
Environmental
GIS

NAVITUS
ENGINEERING INC.



151 Windy Hill Lane
Martinsburg, WV 26002
Telephone: (888) 662-4185
www.navituseng.com

REVISION

DATE

ANTERO
RESOURCES
THIS DOCUMENT
WAS PREPARED
FOR:
ANTERO RESOURCES
APPALACHIAN CORP.

CONSTRUCTION AND E&S CONTROL NOTES

HINTER HEIRS NORTH
CENTRALIZED FRESHWATER IMPOUNDMENT
NEW MILTON DISTRICT
DODDRIDGE COUNTY, WEST VIRGINIA



DATE: 01/21/2013

SCALE: N/A

SHEET 2 OF 18

MATERIAL QUANTITIES

MATERIAL QUANTITIES				
HINTER HEIRS NORTH CENTRALIZED FRESHWATER IMPOUNDMENT				
Item Description	Quantity	Unit	Unit Cost	Item Total
1.0 Mobilization				
(Limited to 10% of Total Base Bid)	1.0	LS	\$	\$
2.0 Erosion & Sediment Control				
2.1 Clearing and Grubbing				
2.1.1 Wooded	5.0	AC	\$	\$
2.1.2 Open Field	0.0	AC	\$	\$
2.2 Silt Fence		LF	\$	\$
2.3 Reinforced Silt Fence		LF	\$	\$
2.4 Super Silt Fence		LF	\$	\$
2.5 12" Compost Filter Sock	285.6	LF	\$	\$
2.6 18" Compost Filter Sock	245.0	LF	\$	\$
2.7 24" Compost Filter Sock	25.4	LF	\$	\$
2.8 32" Compost Filter Sock				
3.0 Unclassified Earthwork				
3.1 Hinter Heirs North Truck Turnaround Pad				
3.1.1 Topsoil Removal to Stockpile (Assume 6" Depth)	347.8	CY	\$	\$
3.1.2 Excavation (Cut to Compact Fill)	0.0	CY	\$	\$
3.1.3 Excavation (Import from Stockpile)	11,246.2	CY	\$	\$
3.2 Hinter Heirs North Centralized Freshwater Impoundment				
3.2.1 Topsoil Removal to Stockpile (Assume 6" Depth)	2,019.7	CY	\$	\$
3.2.2 Excavation (Cut to Compact Fill)	16,852.9	CY	\$	\$
3.2.3 Excavation (Export to Stockpile)	10,471.9	CY	\$	\$
3.3 Excavation/Undiggable Material (Hammering)		CY	\$	\$
3.4 Excavation/Undiggable Material (Blasting)		CY	\$	\$
4.0 Stone and Aggregate Surfacing				
4.1 Hinter Heirs North Truck Turnaround Pad (3" Clean Aggregate) 6" Depth				
4.1.2 Geotextile Fabric (US 200 or Equal)	6,843.6	SF	\$	\$
5.0 Liner System				
5.1 Hinter Heirs North Centralized Freshwater Impoundment				
5.1.1 Primary Liner (60 Mil Textured)	71,390.0	SF	\$	\$
5.1.2 Non-woven Geotextile Fabric Cushion (16 oz.)	71,390.0	SF	\$	\$
6.0 Miscellaneous				
6.1 Hinter Heirs North Centralized Freshwater Impoundment Perimeter Safety Fence				
6.1.1 Woven Wire Fence (4' height)	1,014.2	LF	\$	\$
6.1.2 Wood Treated Fence Post (7' length)	101	EA	\$	\$
6.1.3 Gate	1	EA	\$	\$
6.1.4 Emergency Lifeline	1	EA	\$	\$
6.2 Seeding and Mulching				
6.2.1 Temporary Seeding (Vegetation & Mulch)	3.2	AC	\$	\$
6.2.2 Permanent Seeding (Vegetation & Mulch / Fertilizer/ Lime)	5.0	AC	\$	\$
6.2.3 Lime, Fertilizer, Seeding, and Hydro-Mulch w/tack (HYC2 or Equal)		AC	\$	\$

NOTE:

1. THE SQUARE FOOTAGE FOR THE GEOTEXTILE FABRIC AND THE LINER SYSTEM DOES NOT ACCOUNT FOR MATERIAL OVERLAP AND WASTE.
2. THE MATERIAL QUANTITIES FOR THE ACCESS ROAD CONSTRUCTIONS ARE INCLUDED IN THE HINTER HEIRS SOUTH CENTRALIZED FRESHWATER IMPOUNDMENT PLAN.

HINTER HEIRS NORTH CENTRALIZED FRESHWATER IMPOUNDMENT QUANTITIES						
Description	Cut (CY)	Fill (CY)	Spoil (CY)	Borrow (CY)	Max. Slope	Length of Slope
Truck Turnaround Pad	0.0	11246.2	0.0	11246.2	n/a	n/a
Centralized Freshwater Impoundment	27324.8	16852.9	10471.9	0.0	n/a	n/a
Stripped Topsoil (6")	2367.5	0.0	2367.5	0.0	n/a	n/a
Material Stockpiles	0.0	2370.0	0.0	2370.0	n/a	n/a
Totals	29692.3	30469.1	12839.4	13616.2	n/a	n/a
	Total Spoil (CY) =		-776.8			
Note: Additional material needed for construction of Hinter Heirs North Centralized Freshwater Impoundment shall be borrowed from the Hinter Heirs South Centralized Freshwater Impoundment site.						

THE EARTHWORK QUANTITIES PROVIDED ARE AN ESTIMATE FOR CONSIDERATION. THE QUANTITIES SHOWN ARE CALCULATED USING A 1:1 CUT/SWELL & FILL SHRINK FACTOR. THE QUANTITIES SHOWN MAY BE GREATER OR LESSER THAN ACTUALLY EXCAVATED. THE ENGINEER IS NOT RESPONSIBLE FOR VARIANCES FROM THE ESTIMATED QUANTITIES AND DOES NOT CERTIFY TO THEIR ACCURACY.

Engineering
Survey
Environmental
GIS

NAVITUS
ENGINEERING INC.



151 Wych Hill Lane
Wooden, Virginia 22602
Telephone: (888) 662-4185
www.navituseng.com

REVISION

DATE

ANTERO
RESOURCES
THIS DOCUMENT
WAS PREPARED
FOR:
ANTERO RESOURCES
APPALACHIAN CORP

MATERIAL QUANTITIES

HINTER HEIRS NORTH
CENTRALIZED FRESHWATER IMPOUNDMENT
NEW MILTON DISTRICT
DODDRIDGE COUNTY, WEST VIRGINIA



01/21/2013

DATE: 01/21/2013

SCALE: N/A

SHEET 3 OF 18

EXISTING CONDITIONS

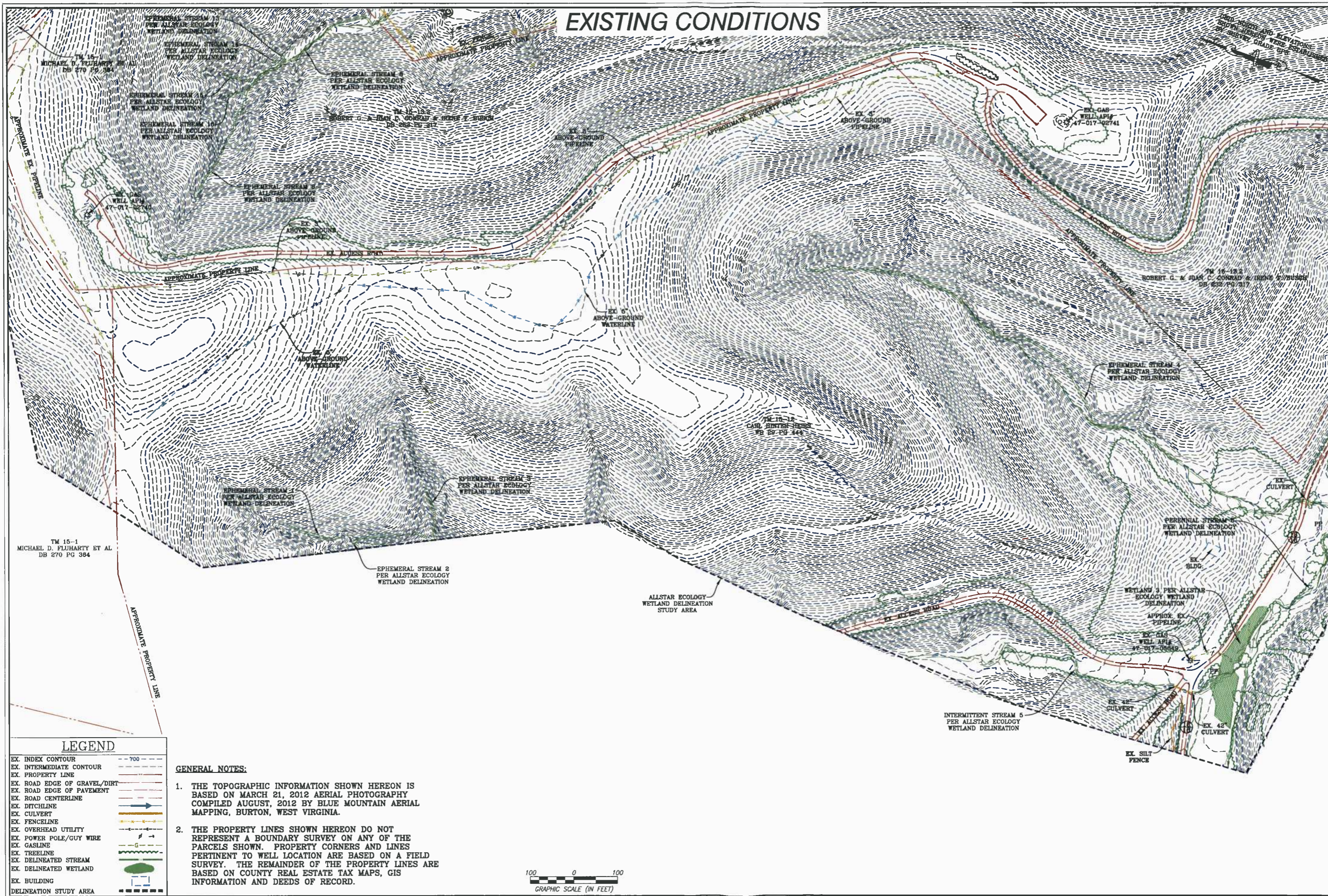

LEGEND

EX. INDEX CONTOUR	--- 700 ---
EX. INTERMEDIATE CONTOUR	--- ---
EX. PROPERTY LINE	---
EX. ROAD EDGE OF GRAVEL/DIRT	---
EX. ROAD EDGE OF PAVEMENT	---
EX. ROAD CENTERLINE	---
EX. DITCHLINE	---
EX. CULVERT	---
EX. FENCELINE	---
EX. OVERHEAD UTILITY	---
EX. POWER POLE/GUY WIRE	---
EX. GASLINE	---
EX. TREELINE	---
EX. DELINEATED STREAM	---
EX. DELINEATED WETLAND	---
EX. BUILDING	---
DELINEATION STUDY AREA	---

- GENERAL NOTES:**
1. THE TOPOGRAPHIC INFORMATION SHOWN HEREON IS BASED ON MARCH 21, 2012 AERIAL PHOTOGRAPHY COMPILED AUGUST, 2012 BY BLUE MOUNTAIN AERIAL MAPPING, BURTON, WEST VIRGINIA.
 2. THE PROPERTY LINES SHOWN HEREON DO NOT REPRESENT A BOUNDARY SURVEY ON ANY OF THE PARCELS SHOWN. PROPERTY CORNERS AND LINES PERTINENT TO WELL LOCATION ARE BASED ON A FIELD SURVEY. THE REMAINDER OF THE PROPERTY LINES ARE BASED ON COUNTY REAL ESTATE TAX MAPS, GIS INFORMATION AND DEEDS OF RECORD.

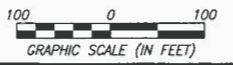

Engineering Survey Environmental GIS

NAVITUS ENGINEERING INC.

151 WINDY HILL LANE
WINCHESTER, VIRGINIA 22602
TELEPHONE: (888) 663-4185
WWW.NAVITUSINC.COM

DATE	REVISION

ANTERO RESOURCES
THIS DOCUMENT WAS PREPARED FOR:
ANTERO RESOURCES
APPALACHIAN CORP

EXISTING CONDITIONS

HINTER HEIRS NORTH

CENTRALIZED FRESHWATER IMPOUNDMENT

NEW MILTON DISTRICT

DODDRIDGE COUNTY, WEST VIRGINIA



DATE: 01/21/2013
SCALE: 1" = 100'
SHEET 4 OF 18

ACCESS ROAD PLAN

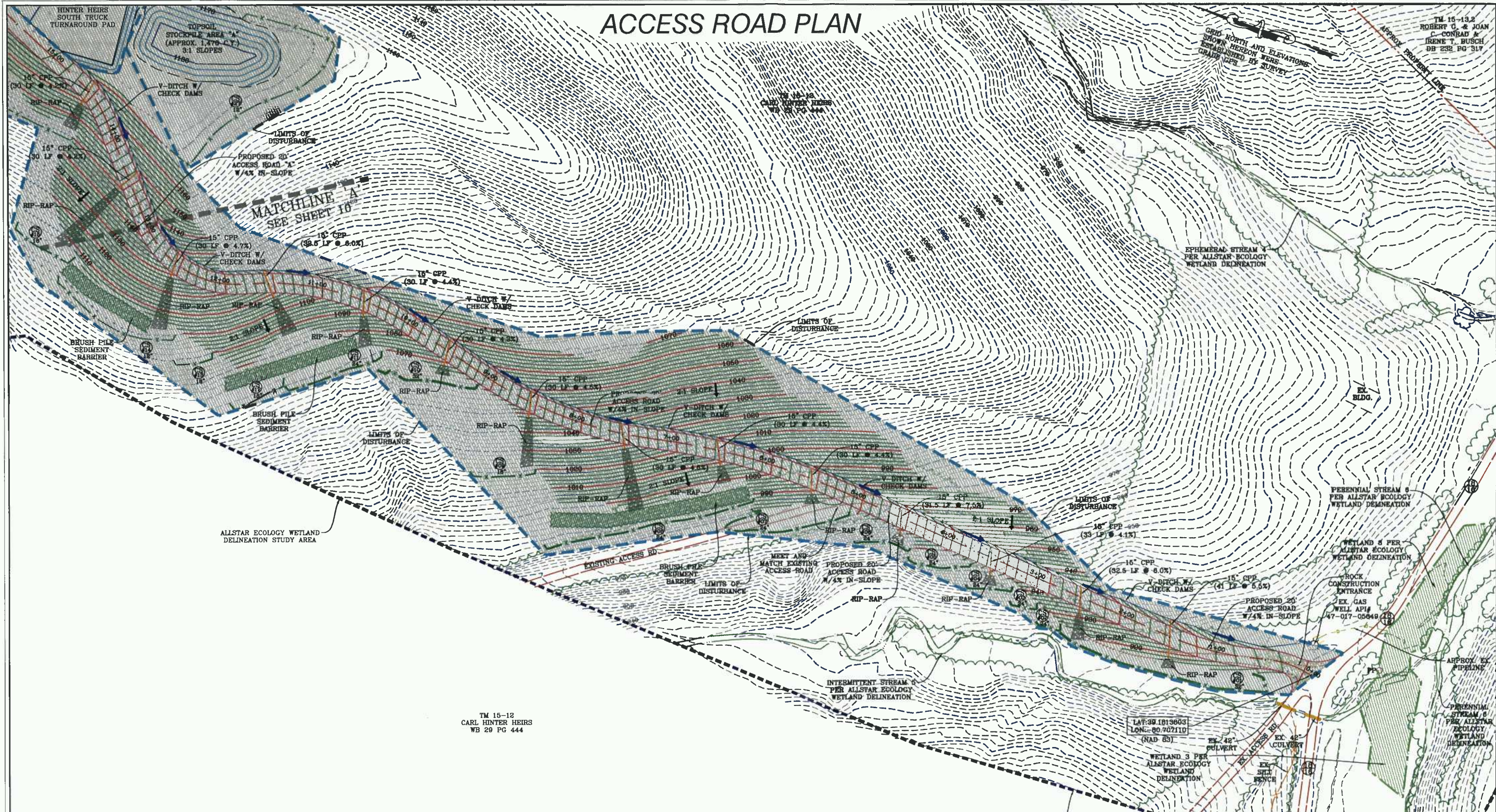

TM 15-12
CARL HINTER HEIRS
WB 29 PG 444

LAT: 38.1013603
LONG: -80.7071110
(NAD 83)

NOTES:
1. ALL PROPOSED DITCH RELIEF AND DRAINAGE CULVERTS SHALL HAVE ADEQUATE OUTLET PROTECTION (4" RIP-RAP) AS SHOWN ON THESE PLANS.
2. ALL FILL AREAS SHALL BE "KEYED IN" AND COMPACTED IN 9" (MAXIMUM) LOOSE LIFT THICKNESS WITH A VIBRATING SHEEPSFOOT ROLLER TO 95% COMPACTION PER STANDARD PROCTOR.

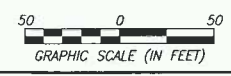

LEGEND			
EX. INDEX CONTOUR	--- 700 ---	PROP. INDEX CONTOUR	--- 700 ---
EX. INTERMEDIATE CONTOUR	--- 700 ---	PROP. INTERMEDIATE CONTOUR	--- 700 ---
EX. PROPERTY LINE	---	PROP. INDEX CONTOUR (ROAD)	--- 700 ---
EX. ROAD EDGE OF GRAVEL/DIRT	---	PROP. INTERMEDIATE CTR (ROAD)	---
EX. ROAD EDGE OF PAVEMENT	---	PROP. LIMITS OF DISTURBANCE	---
EX. ROAD CENTERLINE	---	PROP. WELL HEAD	---
EX. DITCHLINE	---	PROP. PERIMETER SAFETY FENCE	---
EX. CULVERT	---	PROP. ACCESS GATE WITH EMERGENCY LIFELINE	---
EX. FENCELINE	---	PROP. ROAD EDGE OF GRAVEL	---
EX. OVERHEAD UTILITY	---	PROP. ROAD CENTERLINE	---
EX. POWER POLE/GUY WIRE	---	PROP. V-DITCH W/ CHECK DAMS	---
EX. GASLINE	---	PROP. CULVERT W/ RIP-RAP	---
EX. TREELINE	---	PROP. COMPOST FILTER SOCK	---
EX. DELINEATED STREAM	---	PROP. SUPER SILT FENCE	---
EX. DELINEATED WETLAND	---	MATCHLINE	---
EX. BUILDING	---	BRUSH PILE SEDIMENT BARRIER	---
100' WETLAND/STREAM BUFFER DELINEATION STUDY AREA	---		

NAVITUS ENGINEERING INC.
151 Windy Hill Lane
Winchester, Virginia 22602
Telephone: (888) 662-4185
www.navituseng.com

DATE	REVISION

ANTERO RESOURCES
THIS DOCUMENT WAS PREPARED FOR:
ANTERO RESOURCES
APPALACHIAN CORP.

HINTER HEIRS NORTH
CENTRALIZED FRESHWATER IMPOUNDMENT
NEW MILTON DISTRICT
DODDRIDGE COUNTY, WEST VIRGINIA

01/21/2013
DATE: 01/21/2013
SCALE: 1" = 50'
SHEET 6 OF 18

ACCESS ROAD PROFILES

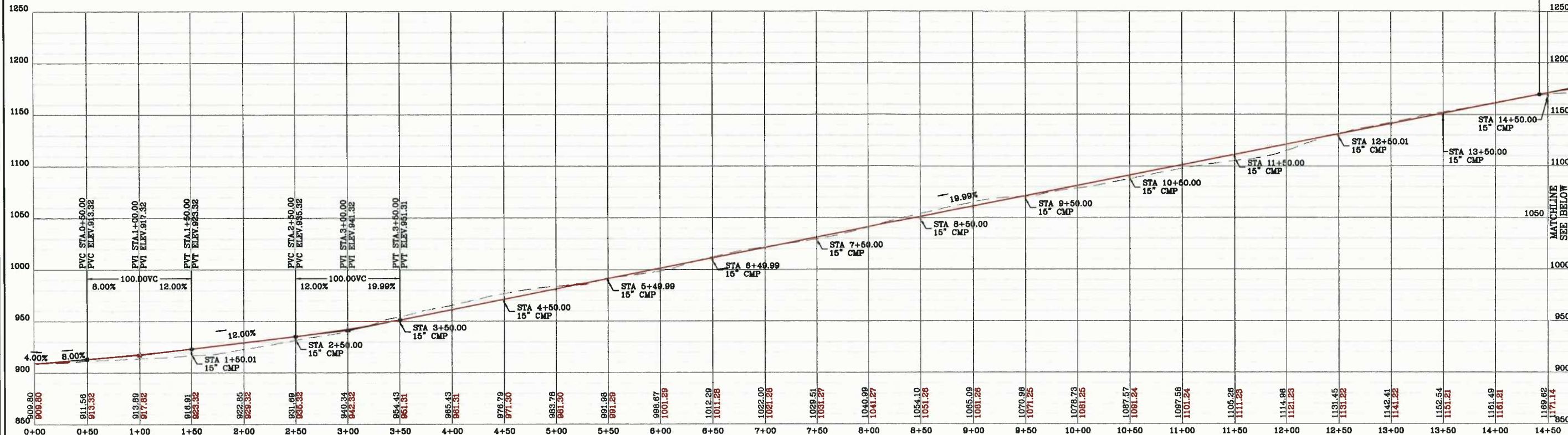

ACCESS ROAD "A" PROFILE
SCALE: HORIZ. 1" = 50' VERT. 1" = 50'

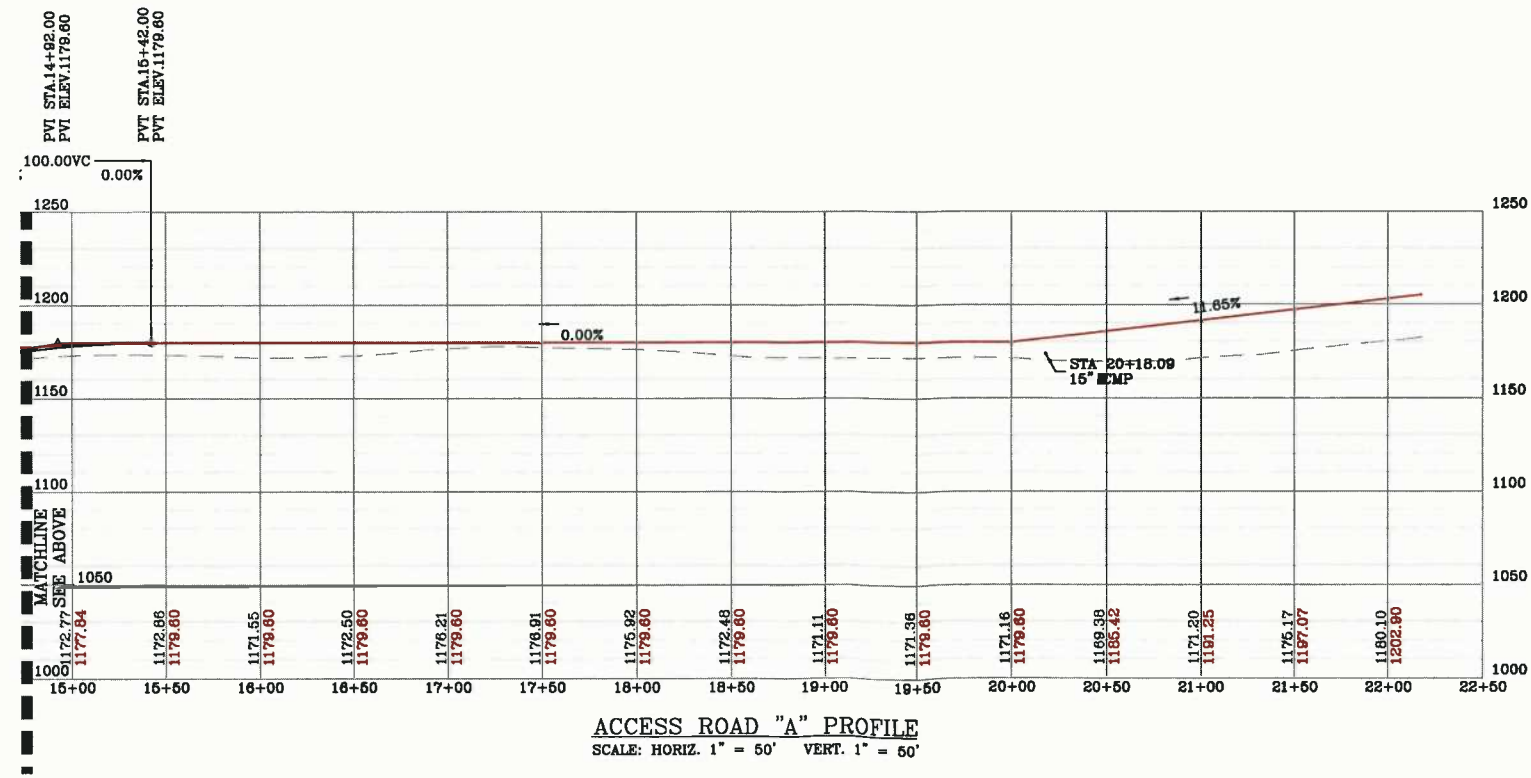

ACCESS ROAD "A" PROFILE
SCALE: HORIZ. 1" = 50' VERT. 1" = 50'

LEGEND

- X-SECTION GRID INDEX
- X-SECTION GRID INTERMEDIATE
- X-SECTION PROPOSED GRADE
- X-SECTION EXISTING GRADE
- X-SECTION WATER SURFACE
- MATCHLINE

Engineering Survey Environmental GIS

NAVITUS ENGINEERING INC.

151 Windy Hill Lane, 27407
Telephone: (888) 663-4185
www.navituseng.com

DATE	REVISION

ANTERO RESOURCES

THIS DOCUMENT WAS PREPARED FOR:

ANTERO RESOURCES
APPALACHIAN CORP

ACCESS ROAD PROFILES

HINTER HEIRS NORTH

CENTRALIZED FRESHWATER IMPOUNDMENT

NEW MILTON DISTRICT

DODDRIDGE COUNTY, WEST VIRGINIA



DATE: 01/21/2013

SCALE: AS SHOWN

SHEET 7 OF 18

ACCESS ROAD SECTIONS

ACCESS ROAD "A" CROSS-SECTIONS

SCALE: HORIZ. 1" = 50' VERT. 1" = 10'

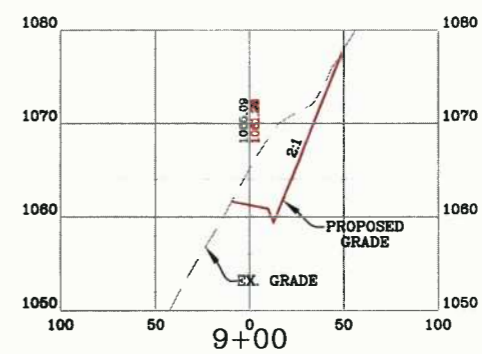
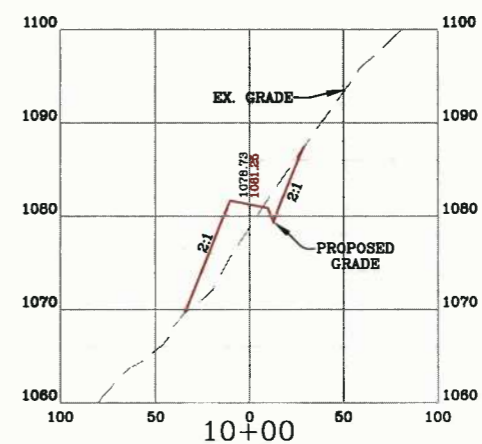
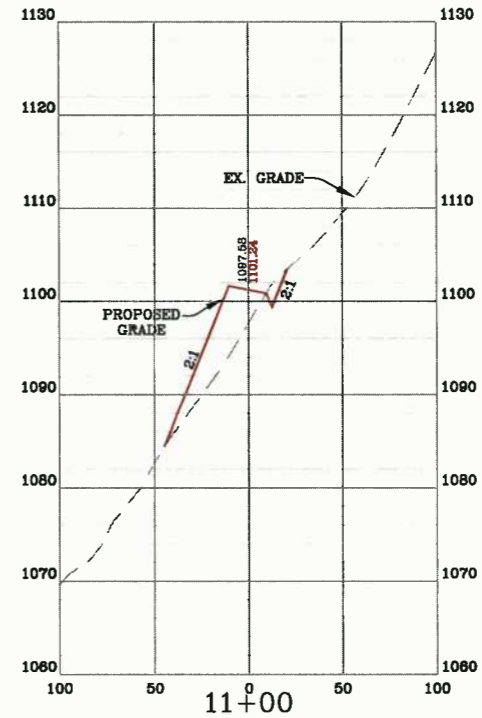
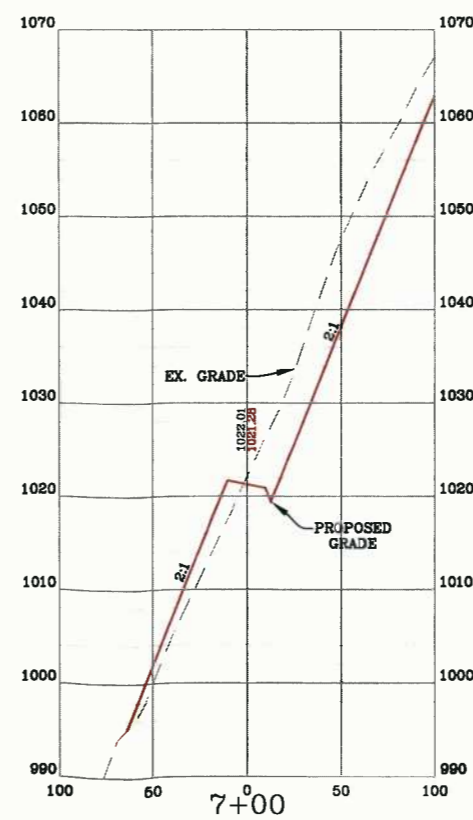
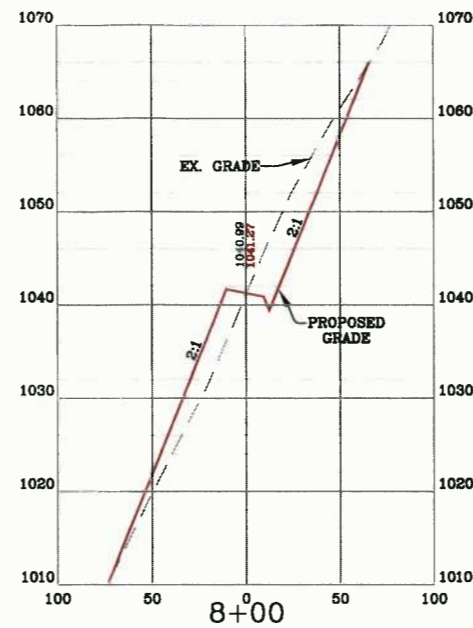
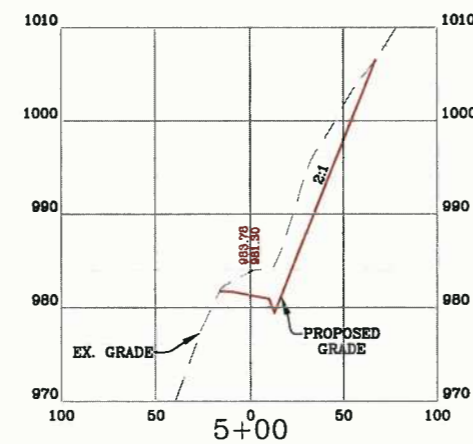
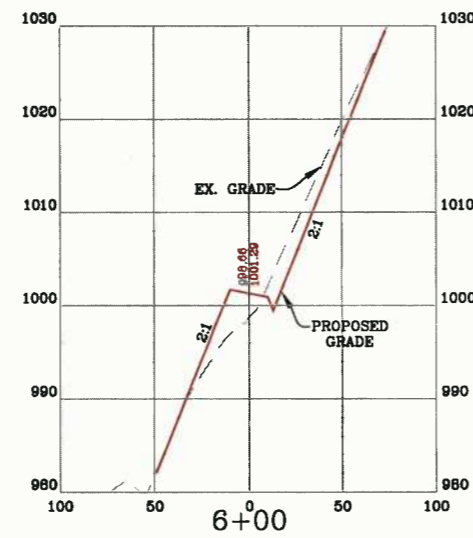
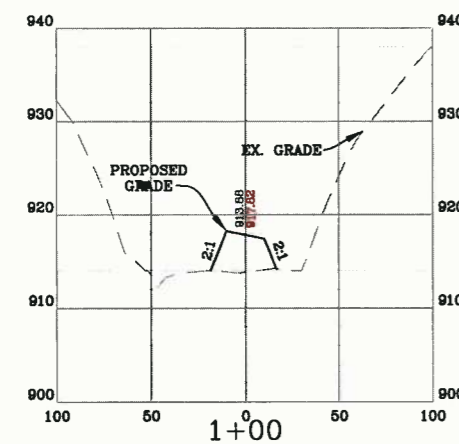
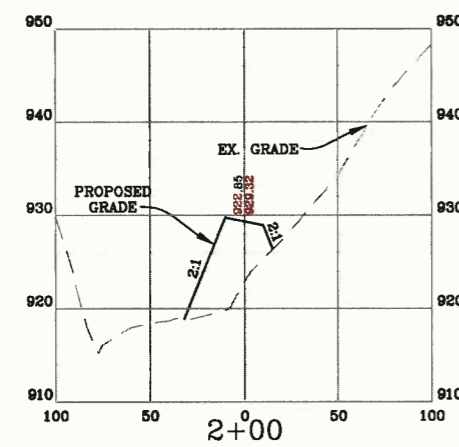
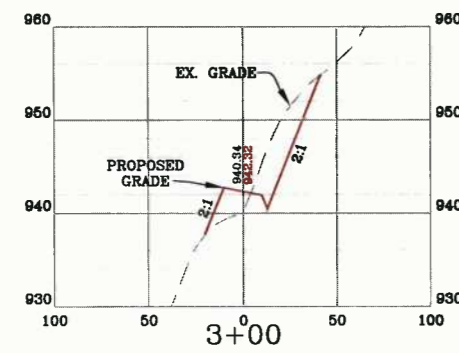
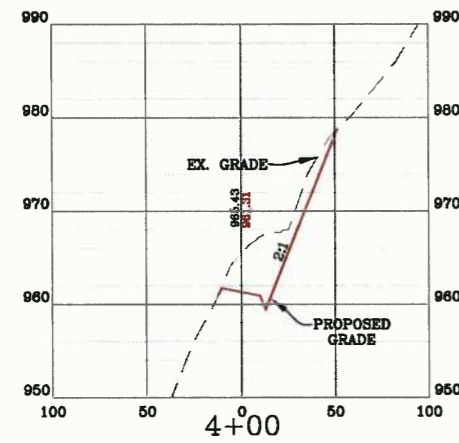

NOTE:
1. ALL CUT & FILL SLOPES ALONG THE ACCESS ROAD SHALL BE 2:1 UNLESS STATED OTHERWISE.

LEGEND	
X-SECTION GRID INDEX	---
X-SECTION GRID INTERMEDIATE	---
X-SECTION PROPOSED GRADE	—
X-SECTION EXISTING GRADE	- - -
X-SECTION WATER SURFACE	—
MATCHLINE	

Engineering
Survey
Environmental
GIS

NAVITUS ENGINEERING INC.
151 Windy Hill Lane
Martinsville, VA 22402
Telephone: (888) 662-4185
www.navituseng.com

DATE	REVISION

ANTERO RESOURCES
THIS DOCUMENT WAS PREPARED FOR:
ANTERO RESOURCES APPALACHIAN CORP

ACCESS ROAD SECTIONS
HINTER HEIRS NORTH
CENTRALIZED FRESHWATER IMPOUNDMENT
NEW MILTON DISTRICT
DODDRIDGE COUNTY, WEST VIRGINIA



DATE: 01/21/2013
SCALE: AS SHOWN
SHEET 8 OF 18

ACCESS ROAD SECTIONS

ACCESS ROAD "A" CROSS-SECTIONS

SCALE: HORIZ. 1" = 50' VERT. 1" = 10'

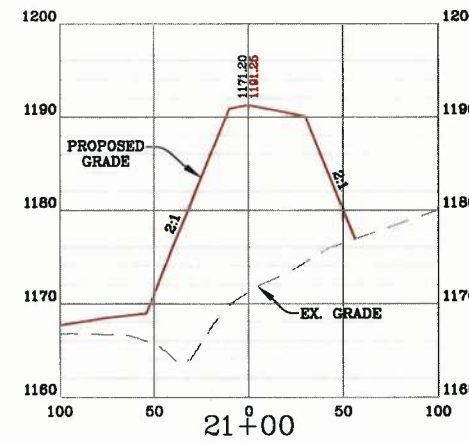
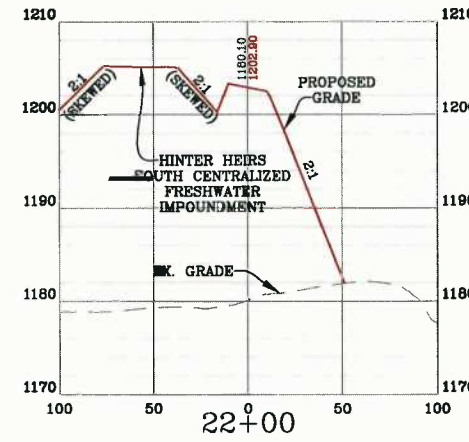
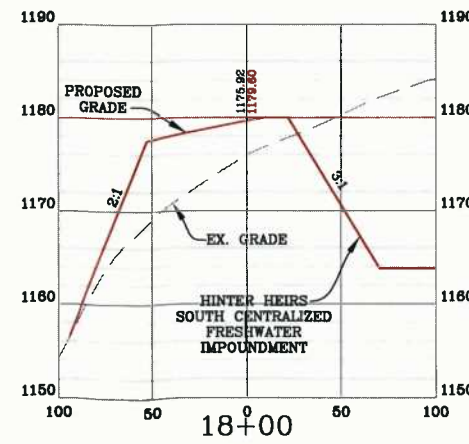
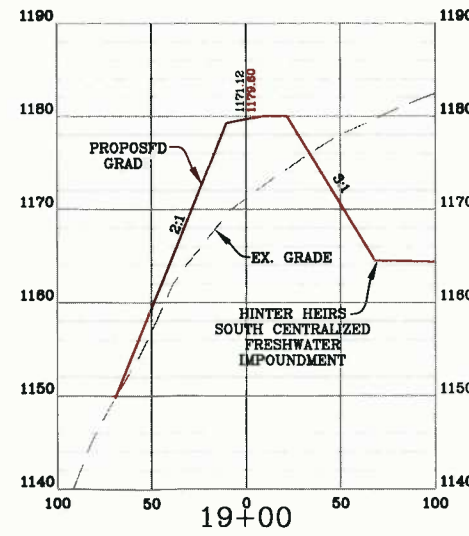
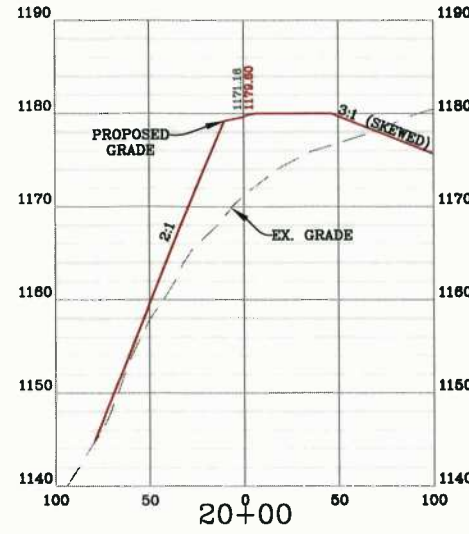
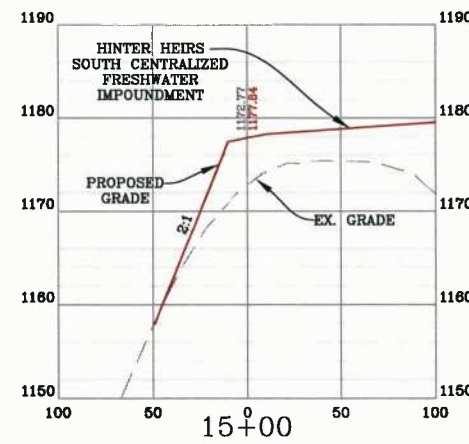
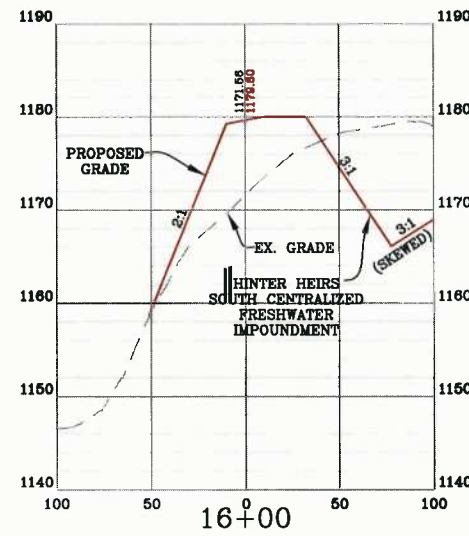
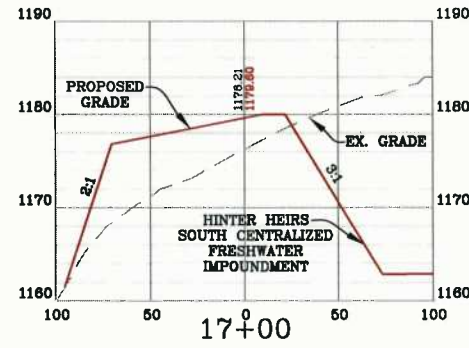
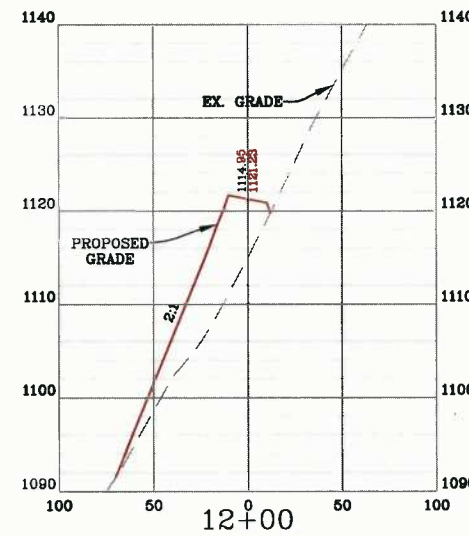
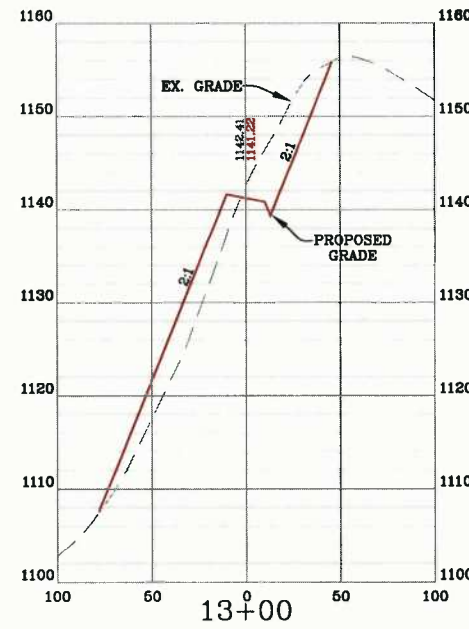
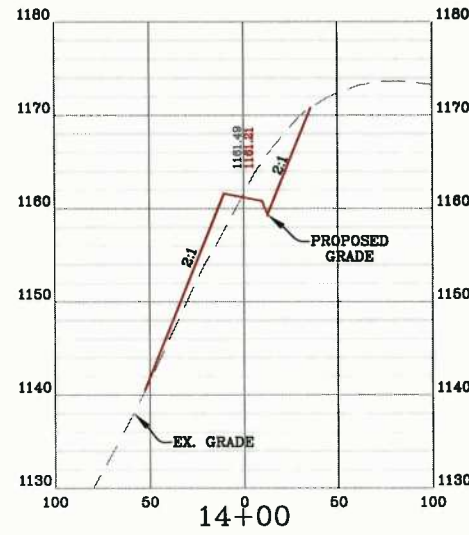

NOTE:
1. ALL CUT & FILL SLOPES ALONG THE ACCESS ROAD SHALL BE 2:1 UNLESS STATED OTHERWISE.

LEGEND	
X-SECTION GRID INDEX	---
X-SECTION GRID INTERMEDIATE	---
X-SECTION PROPOSED GRADE	—
X-SECTION EXISTING GRADE	- - -
X-SECTION WATER SURFACE	—
MATCHLINE	

DATE	REVISION

ANTERO RESOURCES
THIS DOCUMENT
WAS PREPARED
FOR:
ANTERO RESOURCES
APPALACHIAN CORP.

ACCESS ROAD SECTIONS
HINTER HEIRS NORTH
CENTRALIZED FRESHWATER IMPOUNDMENT
NEW MILTON DISTRICT
DODDRIDGE COUNTY, WEST VIRGINIA



DATE: 01/21/2013
SCALE: AS SHOWN
SHEET 9 OF 18

Engineering Survey Environmental GIS

NAVITUS ENGINEERING INC.

151 Windy Hill Lane
Winchester, Virginia 22602
Telephone: (888) 662-4185
www.navituseng.com

CENTRALIZED FRESHWATER IMPOUNDMENT PLAN

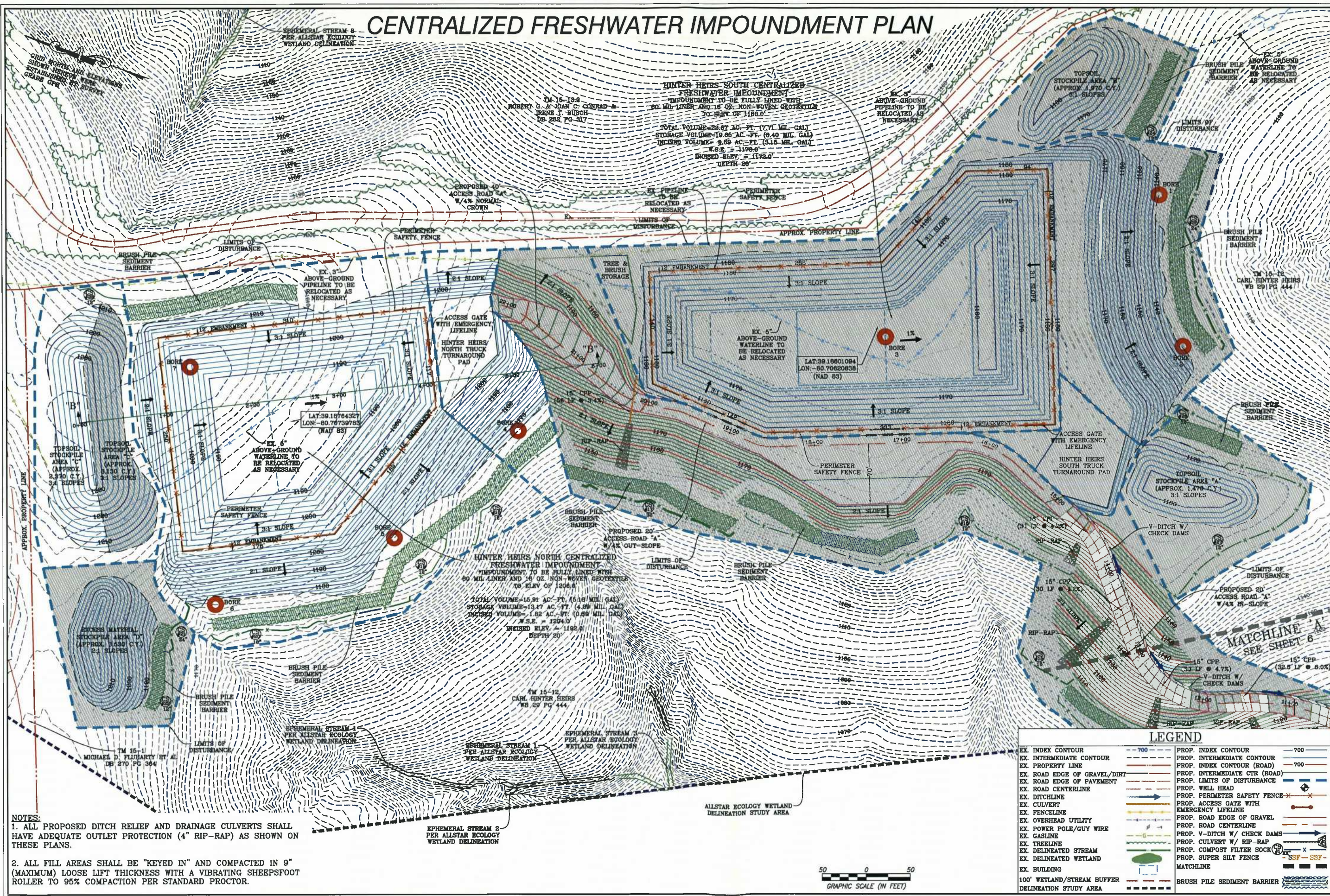

NAVITUS ENGINEERING INC.
 Engineering Survey Environmental GIS
 151 Windy Hill Lane
 Winchester, Virginia 22602
 Telephone: (888) 662-4185
 www.navituseng.com

REVISION	DATE

ANTERO RESOURCES
 THIS DOCUMENT WAS PREPARED FOR:
 ANTERO RESOURCES
 APPALACHIAN CORP.

CENTRALIZED FRESHWATER IMPOUNDMENT PLAN
HINTER HEIRS NORTH
 CENTRALIZED FRESHWATER IMPOUNDMENT
 NEW MILTON DISTRICT
 DODDRIDGE COUNTY, WEST VIRGINIA

LEGISLATIVE SEAL
 REGISTERED PROFESSIONAL ENGINEER
 STATE OF WEST VIRGINIA
 02/21/2013

DATE: 01/21/2013
 SCALE: 1" = 50'
 SHEET 10 OF 18

CENTRALIZED FRESHWATER IMPOUNDMENT SECTIONS



DATE	REVISION

ANTERO RESOURCES
THIS DOCUMENT
WAS PREPARED
FOR:
ANTERO RESOURCES
APPALACHIAN CORP.

CENTRALIZED FRESHWATER IMPOUNDMENT SECTIONS
HINTER HEIRS NORTH
CENTRALIZED FRESHWATER IMPOUNDMENT
NEW MILTON DISTRICT
DODDRIDGE COUNTY, WEST VIRGINIA



DATE: 01/21/2013
SCALE: AS SHOWN
SHEET 11 OF 18

CENTRALIZED FRESHWATER IMPOUNDMENT CROSS-SECTIONS ALONG BASELINE "B-B"

SCALE: HORIZ. 1" = 50' VERT. 1" = 10'

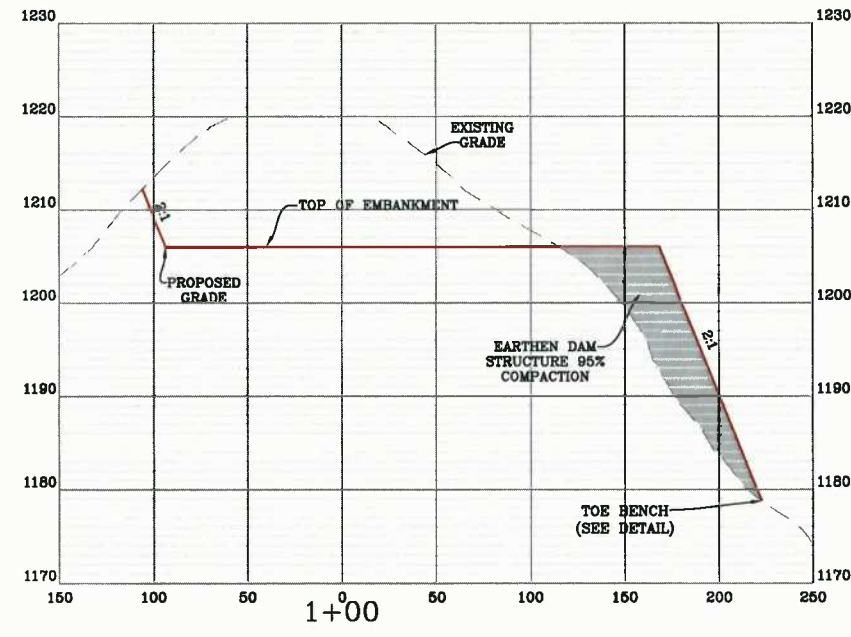
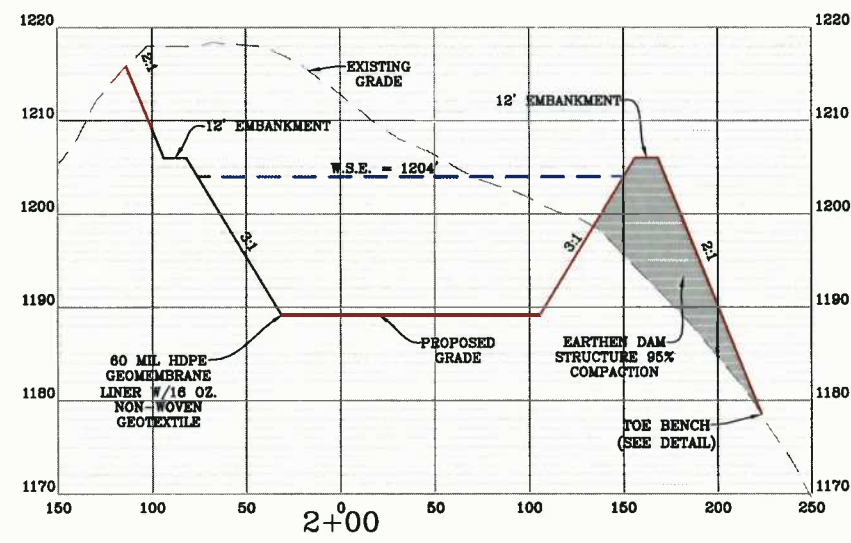
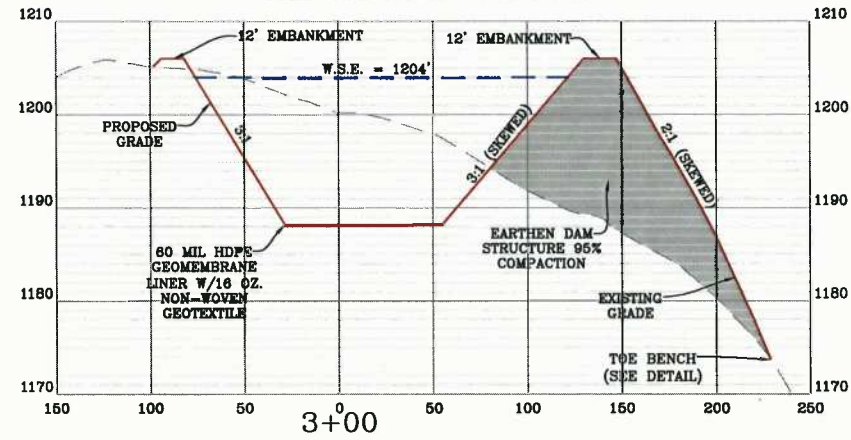

CENTRALIZED FRESHWATER IMPOUNDMENT CROSS-SECTION "B-B"

SCALE: HORIZ. 1" = 50' VERT. 1" = 10'

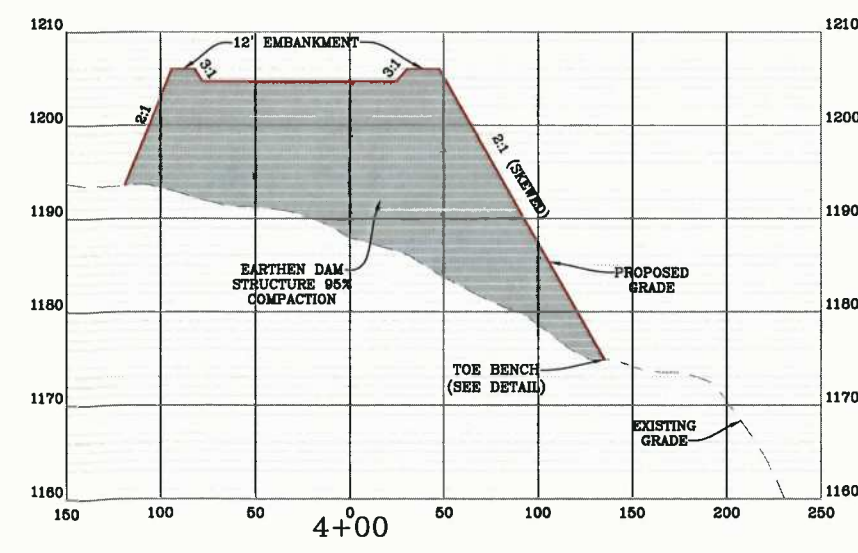
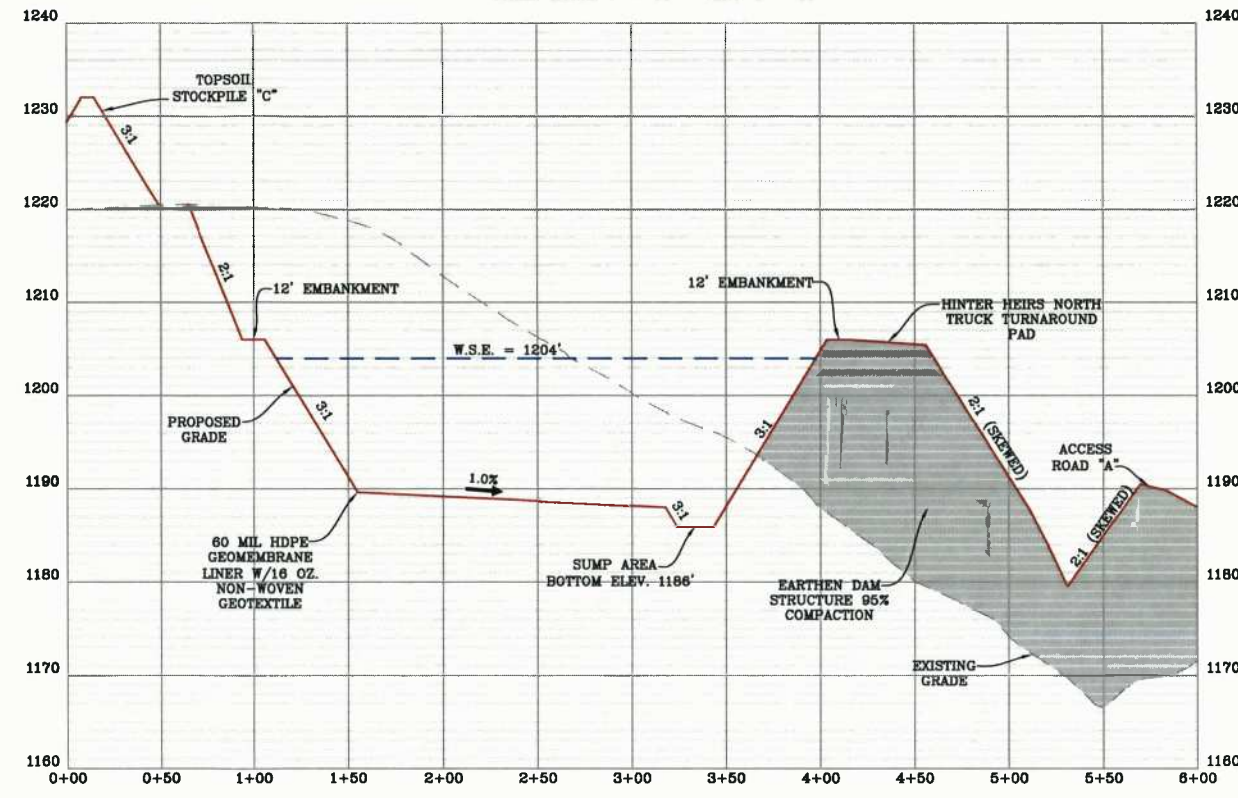

NOTE:
1. ALL FILL AREAS SHALL BE "KEYED IN" AND COMPACTED IN 9" (MAXIMUM) LOOSE LIFT THICKNESS WITH A VIBRATING SHEEPSFOOT ROLLER TO 95% COMPACTION PER STANDARD PROCTOR.

LEGEND	
X-SECTION GRID INDEX	---
X-SECTION GRID INTERMEDIATE	---
X-SECTION PROPOSED GRADE	—
X-SECTION EXISTING GRADE	- - -
X-SECTION WATER SURFACE	—
MATCHLINE	

FIGURE 3.02.1

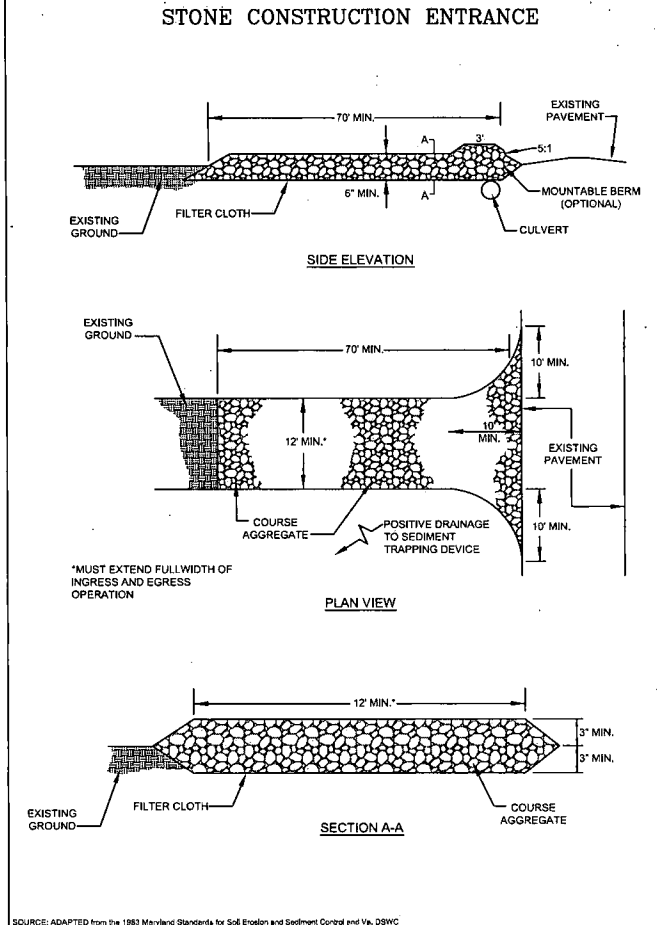

SOURCE: ADAPTED FROM THE 1983 MARYLAND STANDARDS FOR SOIL EROSION AND SEDIMENT CONTROL AND VA, DSWC

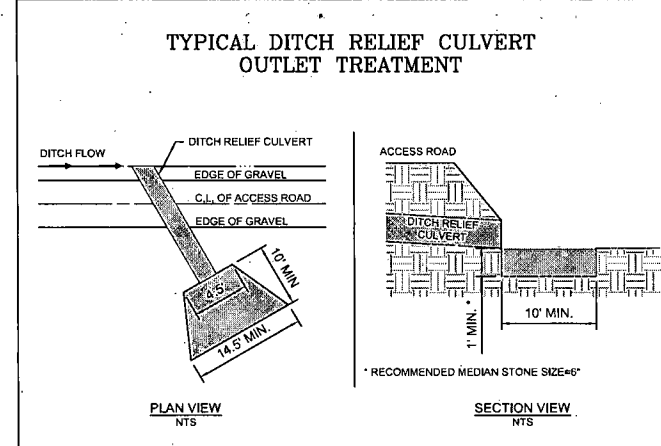

NOTE:
 ALL DITCH LINE PROTECTION SHALL BE INSTALLED AS RECOMMENDED IN THE WEST VIRGINIA EROSION AND SEDIMENT CONTROL BEST MANAGEMENT PRACTICE (BMP) MANUAL. DITCH LINE PROTECTION SHALL BE BASED ON THE FOLLOWING GRADES:

1. LESS THAN 3% - GRASSED
2. 3-8% - GRASS WITH ROLLED EROSION CONTROL PRODUCTS (RECP)
3. GREATER THAN 8% - RIPRAP OR EQUIVALENT GEOTEXTILE

IF HIGH EROSION SOILS ARE ENCOUNTERED DURING CONSTRUCTION, THE ENGINEER SHOULD BE CONTACTED FOR FURTHER EVALUATION.

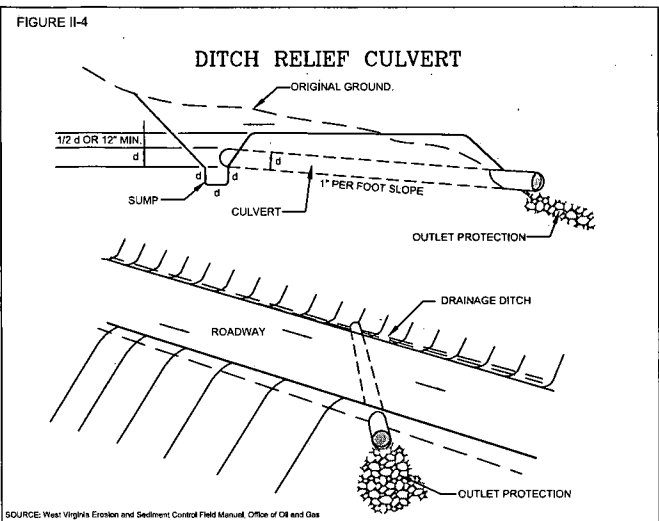
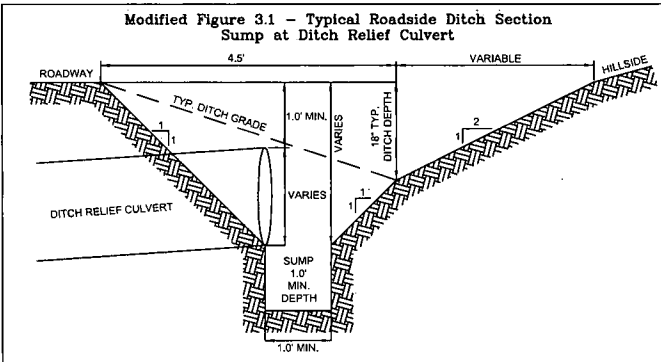

FIGURE 3.13.1

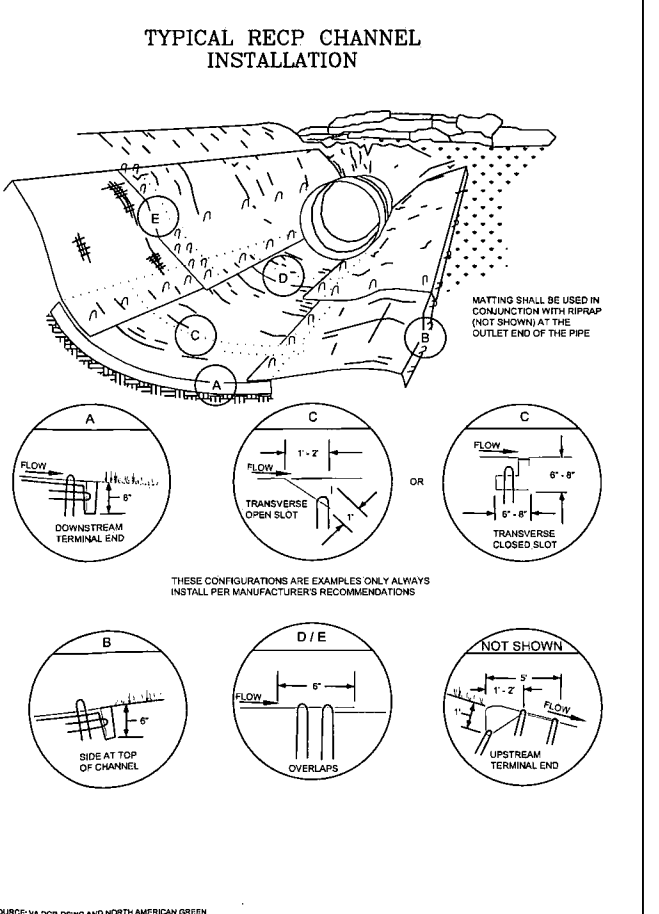

Table II-5
Pipe Sizes for Culverts Across Roads

Drainage Area (Ac)	Pipe Diameter (in)	Pipe Capacity (Cfs)
10	15	5
20	18	9
30	21	12
50	24	16
80	27	24
100	30	29
300	36	60
500	42	85

Table II-6
Spacing of Culverts

Road Grade %	Distance (Ft)
2-5	500-300
6-10	300-200
11-15	200-100
16-20	100

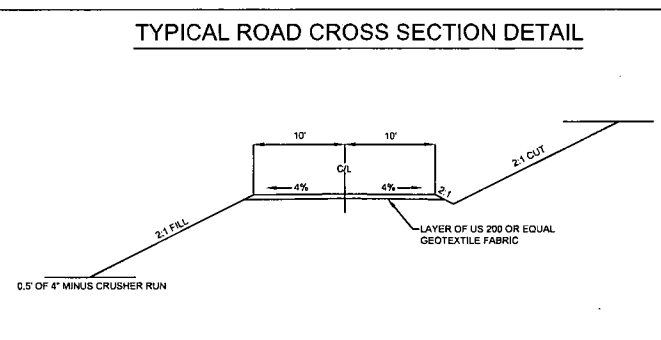
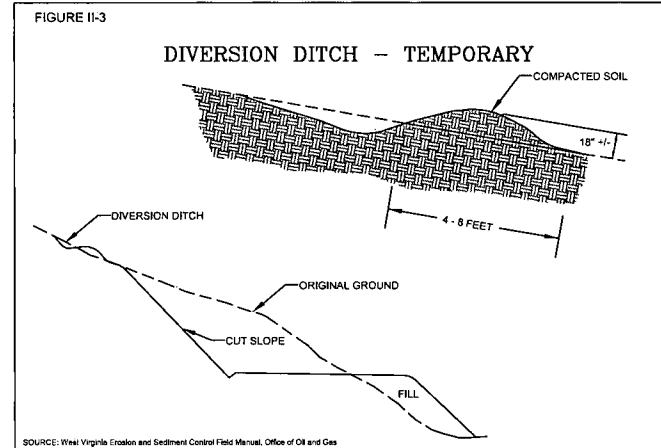
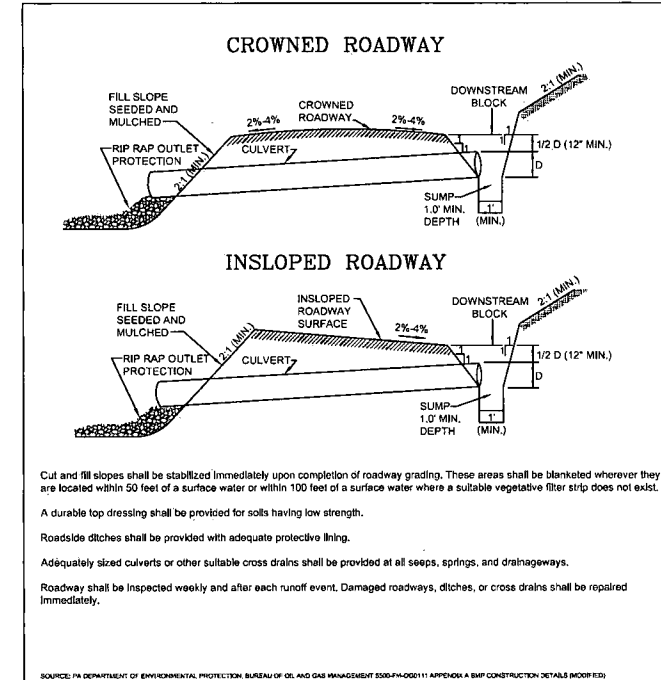
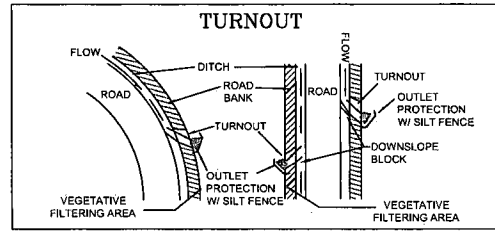
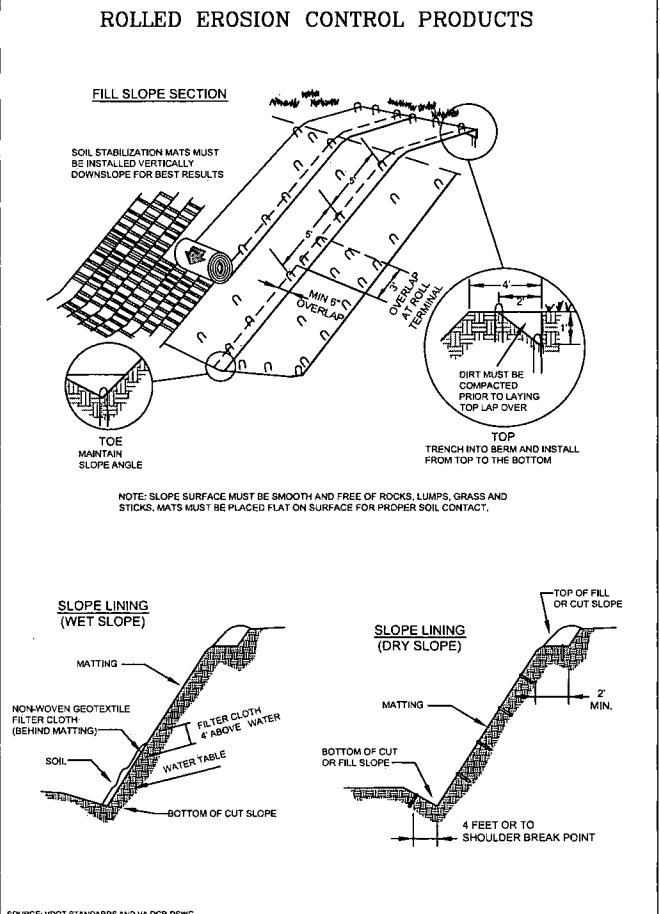

FIGURE 3.13.2



Engineering Survey Environmental GIS

NAVITUS ENGINEERING INC.
 151 Windy Hill Lane
 Winchester, Virginia 22602
 Telephone: (888) 662-4185
 www.navituseng.com

REVISION	DATE

CONSTRUCTION DETAILS

HINTER HEIRS NORTH
 CENTRALIZED FRESHWATER IMPOUNDMENT
 NEW MILTON DISTRICT
 DODDRIDGE COUNTY, WEST VIRGINIA

REGISTERED PROFESSIONAL ENGINEER
 STATE OF WEST VIRGINIA
 01/21/2013

DATE: 01/21/2013
 SCALE: N/A
 SHEET 12 OF 18

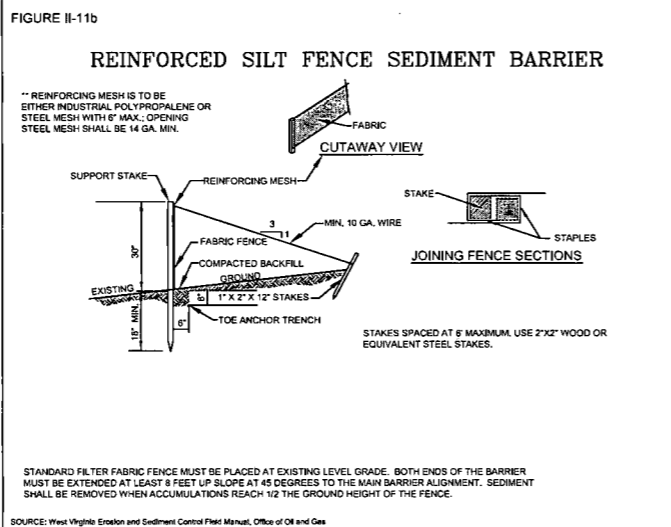
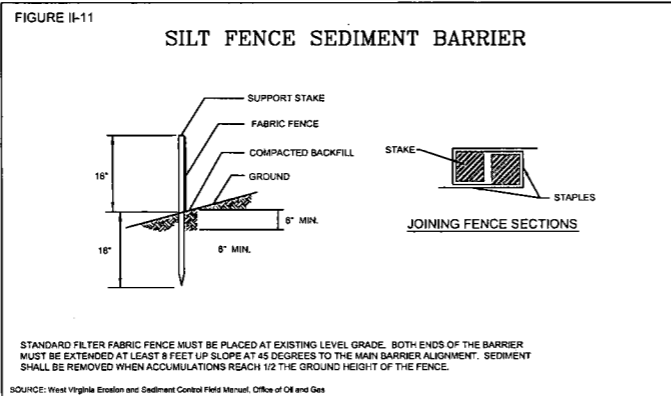
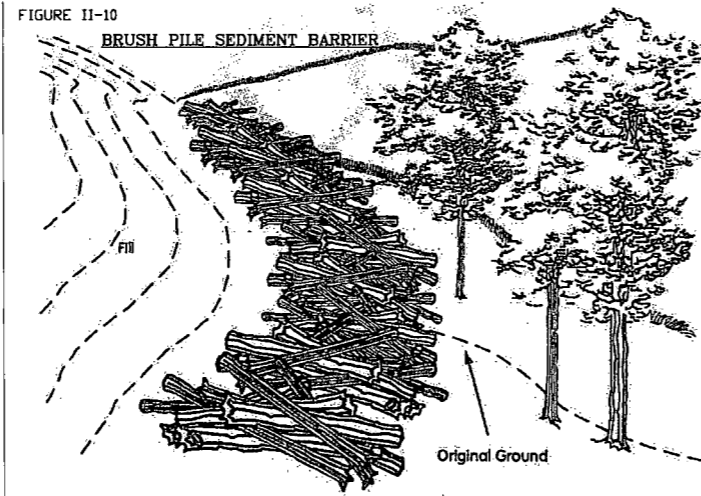
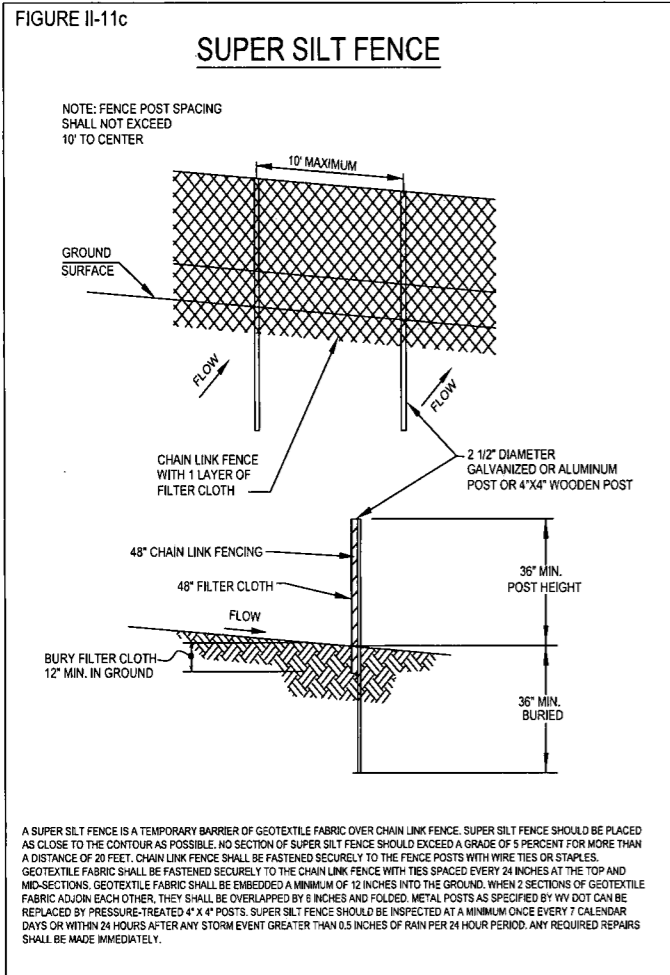
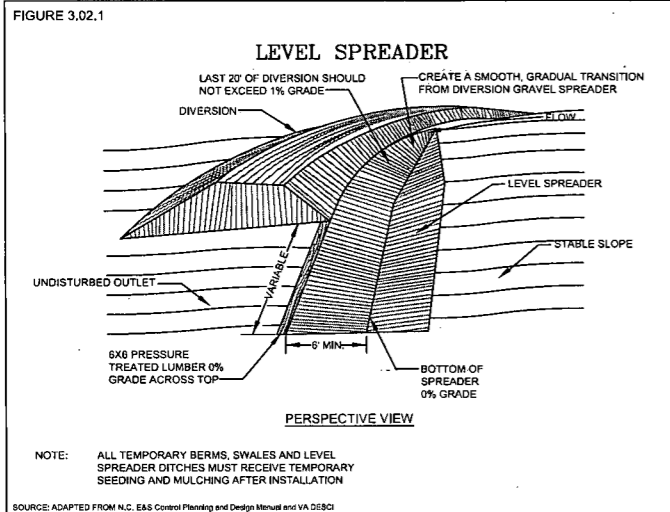
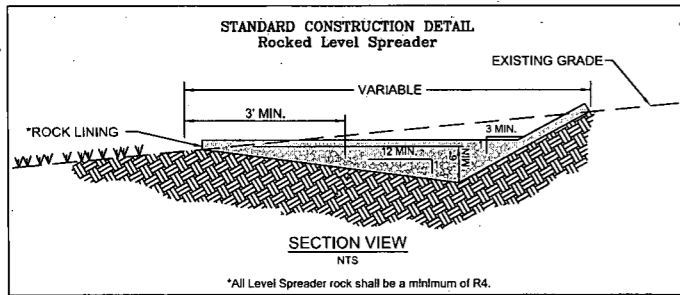

Table 4.1
Compost Sock Fabric Minimum Specifications

Material Type	3 mil HDPE Photo-degradable	5 mil HDPE Photo-degradable	5 mil HDPE Bio-degradable	Multi-Filament Polypropylene (MFFF) Photo-degradable	Heavy Duty Multi-Filament Polypropylene (HDMPF) Photo-degradable
Sock Diameter	12" 18"	12" 18" 24" 36"	12" 18" 24" 36"	12" 18" 24" 36"	12" 18" 24" 36"
Mesh Opening	3/8"	3/8"	3/8"	3/8"	1/8"
Tensile Strength		28 psi	28 psi	44 psi	202 psi
Ultraviolet Stability % Original Strength (ASTM G-155)	23% at 1000 hr.	23% at 1000 hr.		100% at 1000 hr.	100% at 1000 hr.
Minimum Functional Longevity	8 months	9 months	8 months	1 year	2 years

Two-ply systems

Inner Containment Netting	HDPE biaxial net Continuously wound Fusion-welded junctures
Outer Filtration Mesh	3/4" x 3/4" Max. aperture size Composite Polypropylene Fabric (Woven layer & non-woven fleeces mechanically fused via needle punch) 3/16" Max. aperture size

Sock fabrics composed of burlap may be used on projects lasting 8 months or less.

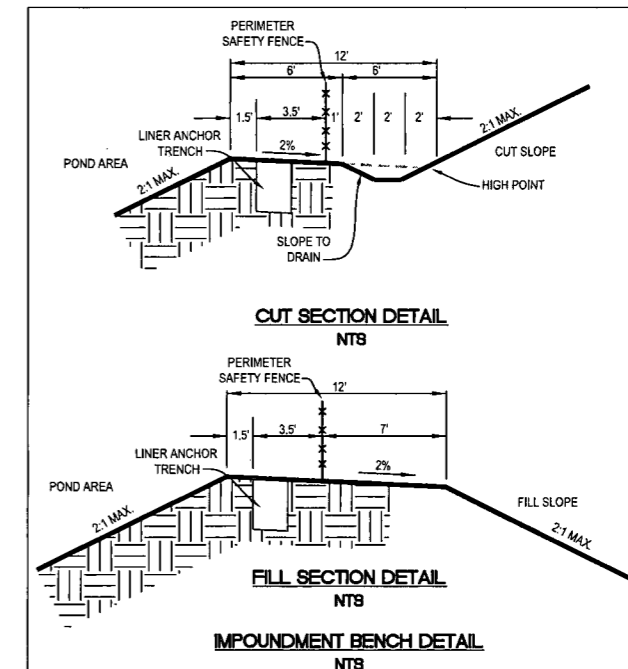
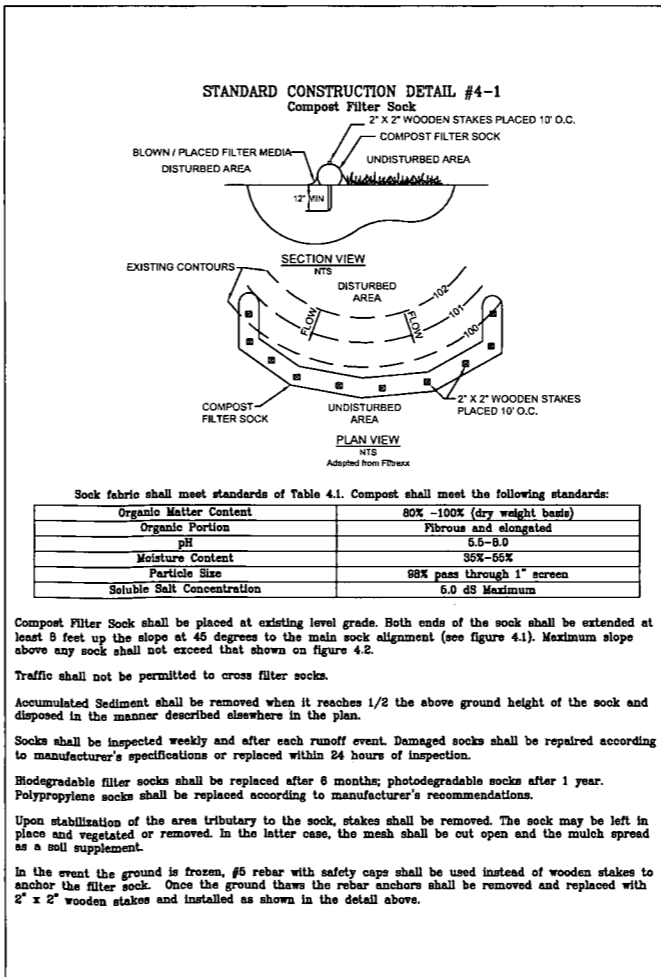
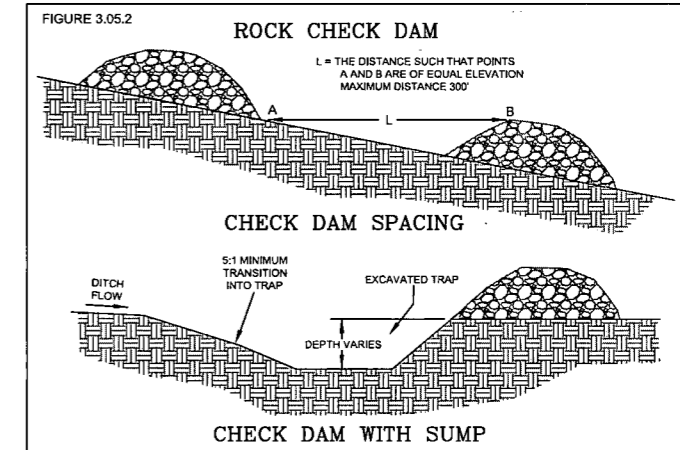
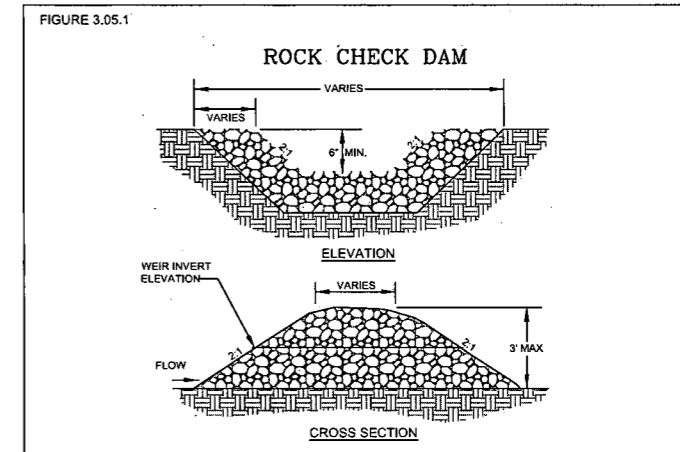

Engineering Survey Environmental GIS

NAVITUS ENGINEERING INC.

151 Windy Hill Lane
Winchester, Virginia 22602
Telephone: (888) 665-4185
www.navituseng.com

REVISION	DATE

ANTERO RESOURCES
THIS DOCUMENT
WAS PREPARED
FOR:
ANTERO RESOURCES
APPALACHIAN CORP.

CONSTRUCTION DETAILS

HINTER HEIRS NORTH
CENTRALIZED FRESHWATER IMPOUNDMENT
NEW MILTON DISTRICT
DODDRIDGE COUNTY, WEST VIRGINIA

REGISTERED PROFESSIONAL ENGINEER
STATE OF WEST VIRGINIA
01/21/2013

DATE: 01/21/2013
SCALE: N/A
SHEET 13 OF 18

REVEGETATION

Taken from the
West Virginia Erosion and Sediment Control Field Manual
West Virginia Division of Environmental Protection Office of Oil and Gas
Charleston, W.Va.
Section IV

Temporary Seeding

a. General Conditions Where Practice Applies

Where exposed soil surfaces are not to be fine-graded or worked for periods longer than 21 days. Temporary vegetative cover with sediment controls must be established where runoff will go directly into a stream. Immediately upon construction of the site (site includes road and location), vegetation must be established on road bank and location slopes. A permanent vegetative cover shall be applied to areas that will be left un-worked for a period of more than six months.

b. Seed Mixtures and Planting Dates

Refer to Tables 2 through 4 for recommended dates to establish vegetative cover and the approved lists of temporary and permanent plant species, and planting rates. Table 3 gives recommended types of temporary vegetation, rates of application, and optimum seeding dates. In situations where another cover is desired, contact the local soil conservation district for seeding recommendations.

c. Seed Application

Apply seed by broadcasting, drilling, or by hydroseed according to the rates indicates in Table IV-3. Perform all planting operations at right angles to the slope. Necessary site preparation and roughening of the soil surface should be done just prior to seeding. Seedbed preparation may not be required on newly disturbed areas.

Permanent Seeding

a. General

Permanent vegetative cover will be established where no further soil disturbance is anticipated or needed. Soil fertility and pH level should be tested and adjusted according to seed species planted. Planting of permanent vegetative covers must be performed on all disturbed areas after completion of the drilling process. Any site that contains significant amounts of topsoil shall have the topsoil removed and stockpiled when feasible. Topsoil should not be added to slopes steeper than 2:1 unless a good bonding to the sub-layer can be achieved. After proper grading and seedbed preparation, the vegetation will reestablish ground cover for the control of surface water runoff erosion.

All required seedbed preparation and loosening of soil by disking or dozer tracking should be performed just prior to seeding. If seedbed preparation is not feasible, 60% more seed shall be added to the recommended rates shown in Tables IV-3 and IV-4.

When hydroseeding, seedbed preparation may not be necessary if adequate site preparation was performed. Incorporate the appropriate amount of lime and/or fertilizer in the slurry mix when hydroseeding.

When hydroseeding, first mix the lime, fertilizer, and hydro-mulch in the recommended amount of water. Mix the seed and inoculants together within one hour prior to planting, and add to the slurry just before seeding. Apply the slurry uniformly over the prepared site. Assure that agitation is continuous throughout the seeding operation and the mix is applied within one hour of initial mixing.

b. Lime and Fertilizer

1. Lime shall be applied to all permanent seedings. The pH of the soil is to be determined and lime applied accordingly. Once the pH is known, select the amount of lime to be applied from Table IV-5.

2. Fertilizer shall be applied in all permanent seedings. Apply the equivalent for 500 lbs. minimum 10-20-20 fertilizer per acre or use the amount of fertilizer and lime recommended by a certified soil test.

3. Application: For best results and maximum benefits, the lime and fertilizer are to be applied at the time of seedbed preparation.

c. Permanent Seed Mixtures

Planners should take into consideration the species makeup of the existing pasture and the landowner's future pasture management plans when recommending seed mixtures. Selection: From Tables IV 4a and b, Permanent Seeding Mixtures Suitable for Establishment in West Virginia.

Notes:

- All legumes must be planted with the proper inoculants prior to seeding.
- Lathco Flatpea is potentially poisonous to some livestock.
- Only endophyte free varieties of Tall Fescue should be used. Tall Fescue and Crownvetch are also very invasive species, non-native to WV.
- For unprepared seedbeds or seeding outside the optimum timeframes, add 50% more seed to the specified rate. Mixtures in Table 4b are more wildlife and farm friendly; those listed in bold are suitable for use in shaded woodland settings. Mixtures in italic are suitable for use in filter strips.

d. Seeding for Wildlife Habitat

Consider the use of the native plants or locally adapted plants when selecting cover types and species for wildlife habitat. Wildlife friendly species or mixes that have multiple values should be considered. See wildlife friendly species/mixtures in Table IV-4b. Consider selecting no or low maintenance long-lived plants adaptable to sites which may be difficult to maintain with equipment.

Mulching

a. General Organic Mulches

The application of straw, hay or other suitable materials to the soil surface to prevent erosion. Straw made from wheat or oats is the preferred mulch, the use of hay is permissible, but not encouraged due to the risk of spreading invasive species. Mulch must be applied to all temporary and permanent seeding on all disturbed areas.

Depending on site conditions, in critical areas such as waterways or steep slopes, additional or substitute soil protective measures may be used if deemed necessary. Examples include jute mesh and soil stabilization blankets or erosion control matting. Areas that have been temporarily or permanently seeded should be mulched immediately following seeding. Mulches conserve desirable soil properties, reduce soil moisture loss, prevent crusting and sealing of the soil surface and provide a suitable microclimate for seed germination.

Areas that cannot be seeded because of the season should be mulched to provide some protection to the soil surface. An organic mulch, straw or hay should be used and the area then seeded as soon as weather or seasonal conditions permit. Do not use fiber mulch (cellulose-hydroseed) alone for this practice; at normal application rates it will not give the soil protection of other types of mulch.

Wood cellulose fiber mulch is used in hydroseeding operations and applied as part of the slurry. It creates the best seed-soil contact when applied over the top of (as a separate operation) newly seeded areas. Fiber mulch does not alone provide sufficient protection on highly erodible soils, or during less than favorable growing conditions. Fiber mulch should not be used alone during the dry summer months or when used for late fall mulch cover. Use straw mulch during these periods and fiber mulch may be used to tack (anchor) the straw mulch. Fiber mulch is well suited for steep slopes, critical areas and areas susceptible to wind.

b. Chemical Mulches, Soil Binders and Tackifiers

A wide range of synthetic spray on materials are marketed to stabilize and protect the soil surface. These are mixed with water and sprayed over the mulch and to the soil. They may be used alone in some cases as temporary stabilizers, or in conjunction with fiber mulch, straw or hay. When used alone most chemical mulches do not have the capability to insulate the soil or retain soil moisture that organic mulches have.

c. Specifications

From Table IV-6 select the type of mulch and rate of application that will best suit the conditions at the site.

d. Anchoring

Depending on the field situation, mulch may not stay in place because of wind action or rapid water runoff. In such cases, mulch is to be anchored mechanically or with mulch netting.

1. Mechanical Anchoring

Apply mulch and pull mulch anchoring tool over the mulch. When a disk is used set the disk straight and pull across slope. Mulch material should be tucked into the soil about three inches.

2. Mulch netting

Follow manufacturer's recommendation when positioning and stapling the mulch netting in the soil.

Table IV-1
Recommended Seeding Dates

Planting Dates	Suitability
March 1 - April 15 and August 1 - October 1	Best Seeding Periods
April 15 - August 1	HIGH RISK - moisture stress likely
October 1 - December 1	HIGH RISK - freeze damage to young seedlings
December 1 - March 1	Good seeding period. Dormant seeding

Table 2
Acceptable Fertilization Recommendation

Species	N (lbs/ac)	P2O5 (lbs/ac)	Example Rec. (per acre)
Cool Season Grass	40	80	400 lbs. 10-20-20
CS Grass & Legume	30	60	300 lbs. 10-20-20
Temporary Cover	40	40	200 lbs. 19-19-19

Table 3
Temporary Cover

Species	Seeding Rate (lbs/acre)	Optimum Seeding Dates	Drainage	pH Range
Annual Ryegrass	40	3/1 - 6/15 or 8/15 - 9/15	Well - Poorly	5.5 - 7.5
Field Bromegrass	40	3/1 - 6/15 or 8/15 - 9/15	Well - Mod. Well	6.0 - 7.0
Spring Oats	96	3/1 - 6/15	Well - Poorly	5.5 - 7.0
Sundagrass	40	5/15 - 8/15	Well - Poorly	5.5 - 7.5
Winter Rye	168	8/15 - 10/15	Well - Poorly	5.5 - 7.5
Winter Wheat	180	8/15 - 11/15	Well - Mod. Well	5.5 - 7.0
Japanese Millet	30	6/15 - 8/15	Well	4.5 - 7.0
Redtop	5	3/1 - 6/15	Well	4.0 - 7.5
Annual Ryegrass	26	3/1 - 6/15	Well - Poorly	5.5 - 7.5
Spring Oats	64	3/1 - 6/15	Well - Poorly	5.5 - 7.5

NOTE: These rates should be increased by 50% if planted April 15 - August 1 and October 1 - March 1.

Table 4a
Permanent Seeding Mixture

Species/Mixture	Seeding Rate (lbs/acre)	Soil Drainage preference	pH Range
Crownvetch / Tall Fescue	10 - 15	Well - Mod. Well	5.0 - 7.5
Crownvetch / Perennial Ryegrass	20	Well - Mod. Well	5.0 - 7.5
Flatpea or Perennial Pea / Tall Fescue	20	Well - Mod. Well	4.0 - 8.0
Ladino Clover / Sericea Lespedeza / Tall Fescue	35	Well - Mod. Well	4.5 - 7.5
Tall Fescue / Ladino Clover / Redtop	40	Well - Mod. Well	5.0 - 7.5
Crownvetch / Tall Fescue / Redtop	10	Well - Mod. Well	5.0 - 7.5
Tall Fescue / Birdsfoot Trefoil / Redtop	30	Well - Mod. Well	5.0 - 7.5
Sericea Lespedeza / Tall Fescue / Redtop	25	Well - Mod. Well	4.5 - 7.5
Redtop / Tall Fescue / Creeping Red	30	Well - Mod. Well	5.0 - 7.5
Tall Fescue / Perennial Ryegrass / Tall Fescue / Lathco Flatpea *	50	Well - Poorly	4.5 - 7.5
	10		
	15	Well - Poorly	5.8 - 8.0
	20		

* Lathco Flatpea is potentially poisonous to some livestock. All legumes should be planted with proper inoculants prior to seeding. For unprepared seedbeds or seeding outside the optimum timeframe, add 50% more seed to the specified rate.

Mixtures listed in bold are suitable for use in shaded woodland settings; those in italics are suitable for use in filter strips.

Table 4b
Wildlife and Farm Friendly Seed Mixtures

Species/Mixture	Seeding Rate (lbs/acre)	Soil Drainage preference	pH Range
KY Bluegrass / Redtop	20	Well - Mod. Well	5.5 - 7.5
Ladino Clover or Birdsfoot Trefoil	2 / 10		
Timothy / Alfalfa	5	Well - Mod. Well	6.5 - 8.0
Timothy / Birdsfoot Trefoil	5	Well - Poorly	5.5 - 7.5
Orchardgrass / Ladino Clover / Redtop	10	Well - Mod. Well	5.5 - 7.5
Orchardgrass / Ladino Clover	2	Well - Mod. Well	5.5 - 7.5
Orchardgrass / Perennial Ryegrass	20	Well - Mod. Well	5.5 - 7.5
Creeping Red Fescue / Perennial Ryegrass	30	Well - Mod. Well	5.5 - 7.5
Orchardgrass or KY Bluegrass	10	Well - Mod. Well	6.0 - 7.5
Birdsfoot Trefoil / Redtop / Orchardgrass	10	Well - Mod. Well	5.5 - 7.5
Lathco Flatpea* / Perennial Ryegrass	30	Well - Mod. Well	5.5 - 7.5
Lathco Flatpea* / Orchardgrass	20	Well - Mod. Well	5.5 - 7.5

* Lathco Flatpea is potentially poisonous to some livestock. All legumes should be planted with proper inoculants prior to seeding. For unprepared seedbeds or seeding outside the optimum timeframe, add 50% more seed to the specified rate.

Mixtures listed in bold are suitable for use in shaded woodland settings; those in italics are suitable for use in filter strips.

Table IV-5
Lime and Fertilizer Application Table

pH of Soil	Lime in Tons per Acre	Fertilizer, Lbs. per Acre (10-20-20 or Equivalent)
Above 6.0	2	500
5.0 to 6.0	3	500
Below 5.0	4	500

The pH can be determined with a portable pH testing kit or by sending the soil samples to a soil testing laboratory. When 4 tons of lime per acre are applied it must be incorporated into the soil by disking, backblading or tracking up and down the slope.

Table IV-6
Mulch Materials Rates and Uses

Material	Minimum Rates per acre	Coverage	Remarks
Hay or Straw	2 to 3 Tons	Cover 75% to 90% of Surface	Subject to wind blowing or washing unless tied down
Wood Fiber	100 to 150 bales	Cover all Disturbed Areas	For hydroseeding
Pulp Fiber	1000 to 1500 lbs		
Wood - Cellulose			
Recirculated Paper			

Engineering Survey Environmental GIS

NAVITUS ENGINEERING INC.
151 Windy Hill Lane, 25602
Telephone: (888) 662-4185
www.navituseng.com

REVISION

DATE

CONSTRUCTION DETAILS





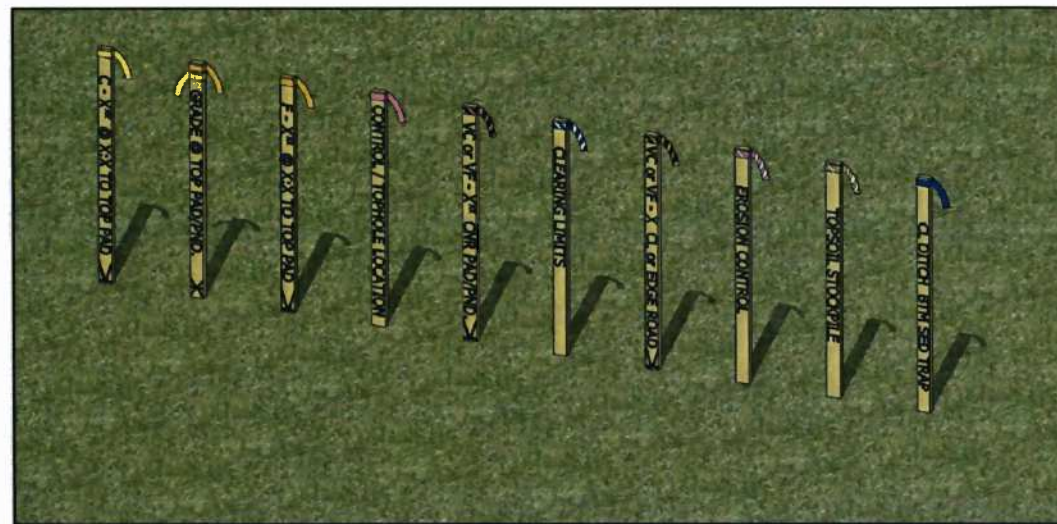

HINTER HEIRS NORTH
CENTRALIZED FRESHWATER IMPOUNDMENT
NEW MILTON DISTRICT
DODDRIDGE COUNTY, WEST VIRGINIA

ANTERO RESOURCES INC. PROJECT WAS PREPARED FOR ANTERO RESOURCES APPALACHIAN CORP.

REGISTERED PROFESSIONAL ENGINEER STATE OF WEST VIRGINIA
01/21/2013

DATE: 01/21/2013
SCALE: N/A
SHEET 14 OF 18



	Yellow Ribbon: Yellow Ribbon used to indicate top of Cuts (C) Cut to be determined at time of stakeout Slope determined by site design
	Yellow & Orange Ribbon: Yellow and Orange Ribbon used to indicate Grade at Top of Pad/Pond/Pit
	Orange Ribbon: Orange Ribbon used to indicate toes of Fills (F) Fill to be determined at time of stakeout Slope determined by site design
	Pink Ribbon: Pink Ribbon used to indicate Top Hole Location Pink Ribbon used to indicate Survey Control Location
	Pink & Black Stripe Ribbon: Pink & Black Stripe Ribbon used to indicate Vertical Cut (VC) at Pad/Pond/Pit corner or edge Pink & Black Stripe Ribbon used to indicate Vertical Fill (VF) at Pad/Pond/Pit corner or edge Vertical Cut/Vertical Fill to be determined at time of stakeout
	Blue & White Stripe Ribbon: Blue & White Stripe Ribbon used to indicate clearing limits/construction limits
	Orange & Black Stripe Ribbon: Orange & Black Stripe Ribbon used to indicate Vertical Cut (VC) at Centerline or edge of access road Orange & Black Stripe Ribbon used to indicate Vertical Fill (VF) at centerline or edge of access road
	Pink & White Stripe Ribbon: Pink & White Stripe Ribbon used to indicate Erosion and Sediment Control Structures Silt Fence (SF) Reinforced Filter Fence (RFF) Super Silt Fence (SSF) Filter Sock (FS)
	Orange & White Stripe Ribbon: Orange & White Stripe Ribbon used to indicate Topsoil Stockpile Locations
	Blue Ribbon: Blue Ribbon used to indicate Centerline (C) Ditch Blue Ribbon used to indicate Bottom (BTM) Sediment Traps

ANTERO RESOURCES APPALACHIAN CORPORATION STANDARD RIBBON COLOR SCHEME
PROVIDED BY ANTERO RESOURCES APPALACHIAN CORPORATION

TYPICAL WOVEN WIRE FENCE DETAIL

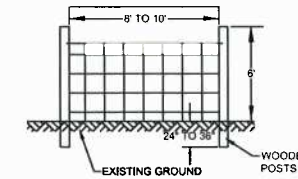

TYPICAL CONSTRUCTION FENCE DETAIL

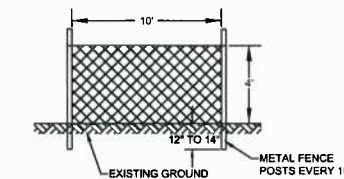

TOE BENCH DETAIL

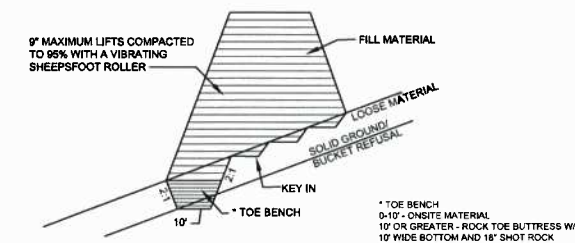

REVISION

DATE



CONSTRUCTION DETAILS

HINTER HEIRS NORTH
CENTRALIZED FRESHWATER IMPOUNDMENT
NEW MILTON DISTRICT
DODDRIDGE COUNTY, WEST VIRGINIA



DATE: 01/21/2013

SCALE: N/A

SHEET 16 OF 18

RECLAMATION PLAN

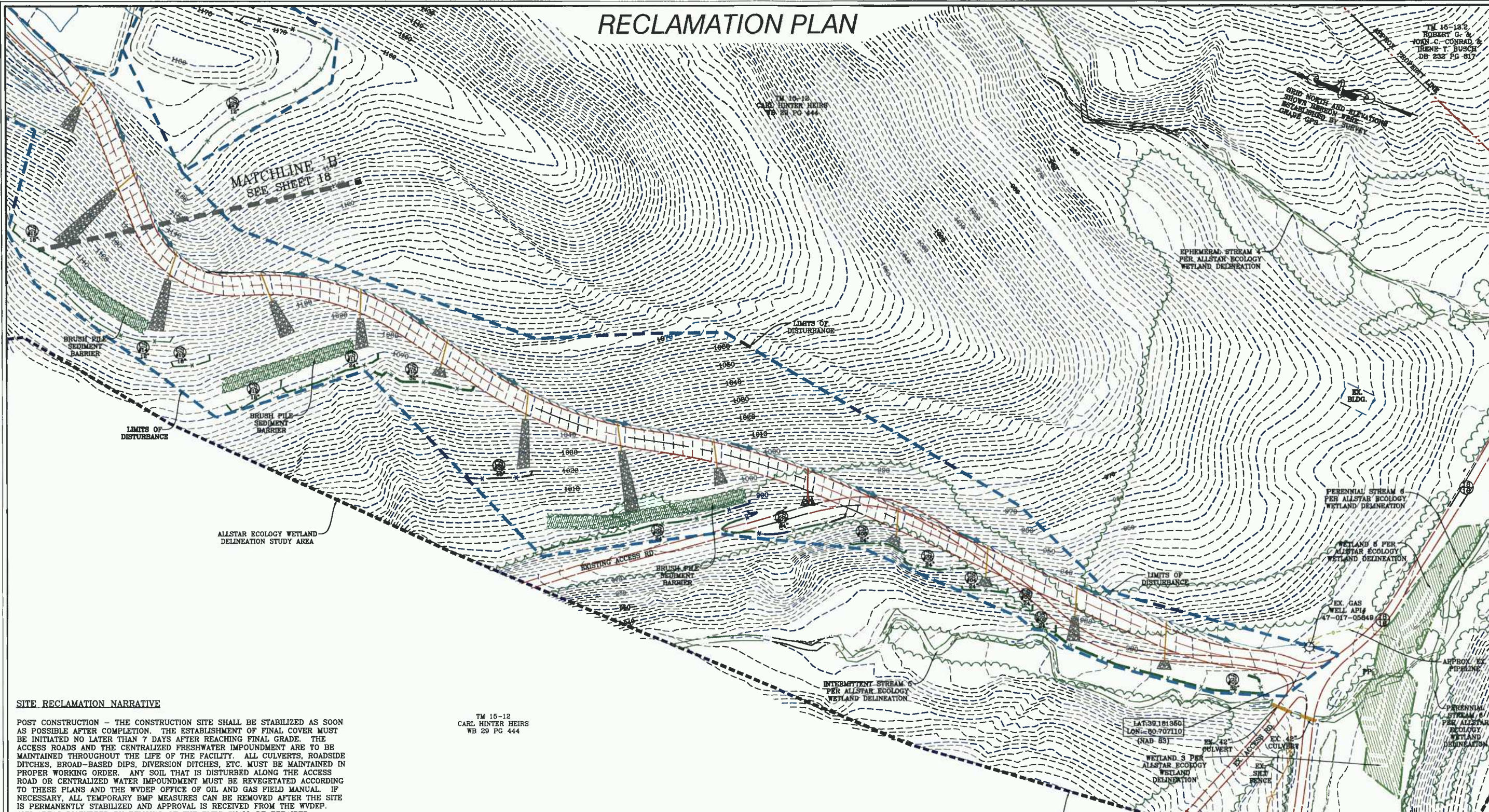

SITE RECLAMATION NARRATIVE

POST CONSTRUCTION - THE CONSTRUCTION SITE SHALL BE STABILIZED AS SOON AS POSSIBLE AFTER COMPLETION. THE ESTABLISHMENT OF FINAL COVER MUST BE INITIATED NO LATER THAN 7 DAYS AFTER REACHING FINAL GRADE. THE ACCESS ROADS AND THE CENTRALIZED FRESHWATER IMPOUNDMENT ARE TO BE MAINTAINED THROUGHOUT THE LIFE OF THE FACILITY. ALL CULVERTS, ROADSIDE DITCHES, BROAD-BASED DIPS, DIVERSION DITCHES, ETC. MUST BE MAINTAINED IN PROPER WORKING ORDER. ANY SOIL THAT IS DISTURBED ALONG THE ACCESS ROAD OR CENTRALIZED WATER IMPOUNDMENT MUST BE REVEGETATED ACCORDING TO THESE PLANS AND THE WVDEP OFFICE OF OIL AND GAS FIELD MANUAL. IF NECESSARY, ALL TEMPORARY BMP MEASURES CAN BE REMOVED AFTER THE SITE IS PERMANENTLY STABILIZED AND APPROVAL IS RECEIVED FROM THE WVDEP. ANY AREAS DISTURBED BY REMOVAL OF THE BMP'S SHALL BE REPAIRED, STABILIZED, AND PERMANENTLY SEEDDED.

POST USE - WITHIN 6 MONTHS OF THE EXPIRATION OF THE CERTIFICATE OF APPROVAL OF THE CENTRALIZED FRESHWATER IMPOUNDMENT FACILITY, THE SITE SHALL BE CLOSED AND RESTORED TO A PRE-CONSTRUCTION CONDITION. THE LINER SYSTEM SHALL BE REMOVED AND DISPOSED OF IN AN APPROVED RECYCLING OR WASTE DISPOSAL FACILITY. ALL PIPING FOR THE GROUNDWATER DEWATERING SYSTEM, WATER LINES, AND ASSOCIATED STRUCTURES SHALL BE REMOVED. ALL EXISTING BMP'S SHOWN SHALL BE INSPECTED FOR DAMAGE AND REPLACED AS NECESSARY BEFORE RECLAMATION CAN BEGIN. THE SITE SHALL BE REGRADED AS INDICATED ON THE PLANS TO PRE-CONSTRUCTION GRADES. UPON COMPLETION OF THE GRADING, THE SITE SHALL BE SEEDDED AND MULCHED PER THE REVEGETATION DETAILS. A NOTICE OF TERMINATION MUST BE FILED WITH THE DEP WHEN THE SITE REACHES FINAL STABILIZATION. FINAL STABILIZATION MEANS THAT ALL SOIL-DISTURBING ACTIVITIES ARE COMPLETED, AND THAT EITHER A PERMANENT VEGETATIVE COVER WITH A DENSITY OF 70% OR GREATER HAS BEEN ESTABLISHED OR THAT THE SURFACE HAS BEEN STABILIZED BY HARD COVER SUCH AS GRAVEL AND PAVEMENT ACCESS ROADS OR BUILDINGS. IT SHOULD BE NOTED THAT THE 70% REQUIREMENT REFERS TO THE TOTAL AREA VEGETATED AND NOT JUST A PERCENT OF THE SITE.

TM 15-12
CARL HINTER HEIRS
WB 29 PG 444

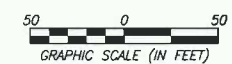

LEGEND	
EX. INDEX CONTOUR	--- 700 ---
EX. INTERMEDIATE CONTOUR	--- 700 ---
EX. PROPERTY LINE	---
EX. ROAD EDGE OF GRAVEL/DIRT	---
EX. ROAD EDGE OF PAVEMENT	---
EX. ROAD CENTERLINE	---
EX. DITCHLINE	---
EX. FENCELINE	---
EX. OVERHEAD UTILITY	---
EX. POWER POLE/GUY WIRE	---
EX. GASLINE	---
EX. TREE LINE	---
EX. DELINEATED STREAM	---
EX. DELINEATED WETLAND	---
EX. BUILDING	---
100' WETLAND/STREAM BUFFER DELINEATION STUDY AREA	---
PROP. INDEX CONTOUR	---
PROP. INTERMEDIATE CONTOUR	---
PROP. INDEX CONTOUR (ROAD)	---
PROP. INTERMEDIATE CTR (ROAD)	---
PROP. LIMITS OF DISTURBANCE	---
PROP. WELL HEAD	---
PROP. PERIMETER SAFETY FENCE	---
PROP. ACCESS GATE WITH EMERGENCY LIFELINE	---
PROP. ROAD EDGE OF GRAVEL	---
PROP. ROAD CENTERLINE	---
PROP. V-DITCH W/ CHECK DAMS	---
PROP. CULVERT W/ RIP-RAP	---
PROP. COMPOST FILTER SOCK	---
PROP. SUPER SILT FENCE	---
MATCHLINE	---
BRUSH PILE SEDIMENT BARRIER	---

Engineering Survey Environmental GIS

NAVITUS ENGINEERING INC.

151 Windy Hill Lane
Winchester, Virginia 22602
Telephone: (888) 662-4185
www.navituseng.com

TM 15-12
ROBERT G. &
JOHN C. CONRAD &
IRENE T. BUSCH
DB 232 PG 017

GRD NORTH AND ELEVATIONS SHOWN HEREON WERE ESTABLISHED BY SURVEY

REVISION	DATE

ANTERO RESOURCES THIS DOCUMENT WAS PREPARED FOR: ANTERO RESOURCES APPALACHIAN CORP.

RECLAMATION PLAN

HINTER HEIRS NORTH

CENTRALIZED FRESHWATER IMPOUNDMENT

NEW MILTON DISTRICT
DODDRIDGE COUNTY, WEST VIRGINIA



DATE: 01/21/2013
SCALE: 1" = 50'
SHEET 17 OF 18

RECLAMATION PLAN

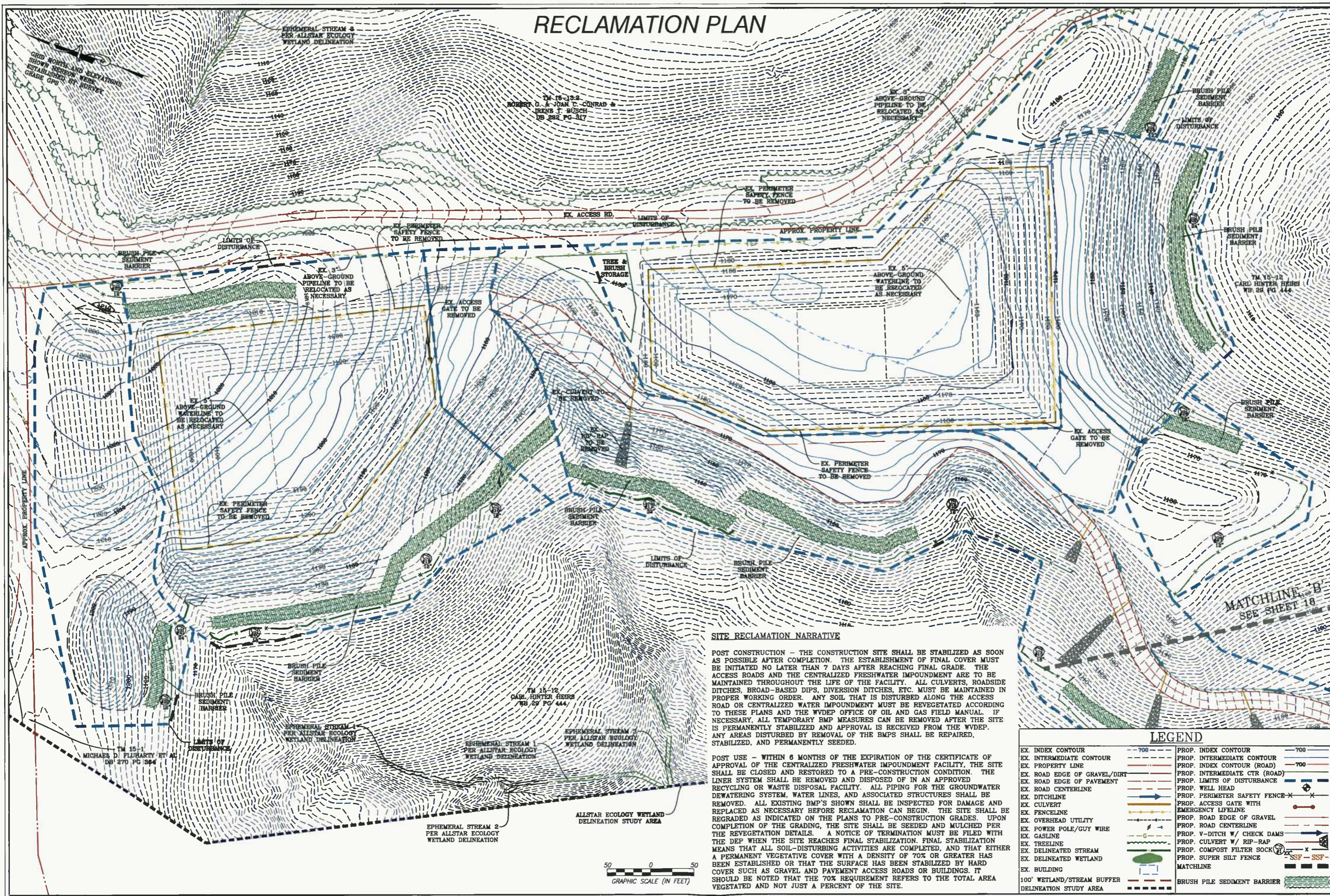

SITE RECLAMATION NARRATIVE

POST CONSTRUCTION - THE CONSTRUCTION SITE SHALL BE STABILIZED AS SOON AS POSSIBLE AFTER COMPLETION. THE ESTABLISHMENT OF FINAL COVER MUST BE INITIATED NO LATER THAN 7 DAYS AFTER REACHING FINAL GRADE. THE ACCESS ROADS AND THE CENTRALIZED FRESHWATER IMPOUNDMENT ARE TO BE MAINTAINED THROUGHOUT THE LIFE OF THE FACILITY. ALL CULVERTS, ROADSIDE DITCHES, BROAD-BASED DIPS, DIVERSION DITCHES, ETC. MUST BE MAINTAINED IN PROPER WORKING ORDER. ANY SOIL THAT IS DISTURBED ALONG THE ACCESS ROAD OR CENTRALIZED WATER IMPOUNDMENT MUST BE REVEGETATED ACCORDING TO THESE PLANS AND THE WVDEP OFFICE OF OIL AND GAS FIELD MANUAL. IF NECESSARY, ALL TEMPORARY BMP MEASURES CAN BE REMOVED AFTER THE SITE IS PERMANENTLY STABILIZED AND APPROVAL IS RECEIVED FROM THE WVDEP. ANY AREAS DISTURBED BY REMOVAL OF THE BMP'S SHALL BE REPAIRED, STABILIZED, AND PERMANENTLY SEEDED.

POST USE - WITHIN 6 MONTHS OF THE EXPIRATION OF THE CERTIFICATE OF APPROVAL OF THE CENTRALIZED FRESHWATER IMPOUNDMENT FACILITY, THE SITE SHALL BE CLOSED AND RESTORED TO A PRE-CONSTRUCTION CONDITION. THE LINER SYSTEM SHALL BE REMOVED AND DISPOSED OF IN AN APPROVED RECYCLING OR WASTE DISPOSAL FACILITY. ALL PIPING FOR THE GROUNDWATER DEWATERING SYSTEM, WATER LINES, AND ASSOCIATED STRUCTURES SHALL BE REMOVED. ALL EXISTING BMP'S SHOWN SHALL BE INSPECTED FOR DAMAGE AND REPLACED AS NECESSARY BEFORE RECLAMATION CAN BEGIN. THE SITE SHALL BE REGRADED AS INDICATED ON THE PLANS TO PRE-CONSTRUCTION GRADES. UPON COMPLETION OF THE GRADING, THE SITE SHALL BE SEEDED AND MULCHED PER THE REVEGETATION DETAILS. A NOTICE OF TERMINATION MUST BE FILED WITH THE DEP WHEN THE SITE REACHES FINAL STABILIZATION. FINAL STABILIZATION MEANS THAT ALL SOIL-DISTURBING ACTIVITIES ARE COMPLETED, AND THAT EITHER A PERMANENT VEGETATIVE COVER WITH A DENSITY OF 70% OR GREATER HAS BEEN ESTABLISHED OR THAT THE SURFACE HAS BEEN STABILIZED BY HARD COVER SUCH AS GRAVEL AND PAVEMENT ACCESS ROADS OR BUILDINGS. IT SHOULD BE NOTED THAT THE 70% REQUIREMENT REFERS TO THE TOTAL AREA VEGETATED AND NOT JUST A PERCENT OF THE SITE.

LEGEND

EX. INDEX CONTOUR	- 700 -	PROP. INDEX CONTOUR	- 700 -
EX. INTERMEDIATE CONTOUR	- - - - -	PROP. INTERMEDIATE CONTOUR	- - - - -
EX. PROPERTY LINE	- - - - -	PROP. INDEX CONTOUR (ROAD)	- 700 -
EX. ROAD EDGE OF GRAVEL/DIRT	- - - - -	PROP. INTERMEDIATE CTR (ROAD)	- - - - -
EX. ROAD EDGE OF PAVEMENT	- - - - -	PROP. LIMITS OF DISTURBANCE	- - - - -
EX. ROAD CENTERLINE	- - - - -	PROP. WELL HEAD	⊗
EX. DITCHLINE	- - - - -	PROP. PERIMETER SAFETY FENCE	⊗
EX. CULVERT	- - - - -	PROP. ACCESS GATE WITH EMERGENCY LIFELINE	⊗
EX. FENCELINE	- - - - -	PROP. ROAD EDGE OF GRAVEL	- - - - -
EX. OVERHEAD UTILITY	- - - - -	PROP. ROAD CENTERLINE	- - - - -
EX. POWER POLE/GUY WIRE	- - - - -	PROP. V-DITCH W/ CHECK DAMS	⊗
EX. GASLINE	- - - - -	PROP. CULVERT W/ RIP-RAP	⊗
EX. TREELINE	- - - - -	PROP. COMPOST FILTER SOCK	⊗
EX. DELINEATED STREAM	- - - - -	PROP. SUPER SILT FENCE	⊗
EX. DELINEATED WETLAND	- - - - -	PROP. BUILDING	⊗
EX. BUILDING	⊗	BRUSH PILE SEDIMENT BARRIER	⊗
100' WETLAND/STREAM BUFFER DELINEATION STUDY AREA	- - - - -	MATCHLINE	- - - - -



NAVITUS ENGINEERING INC.
 Engineering Survey Environmental GIS
 151 Windy Hill Lane
 Winchester, VA 22602
 Telephone: (888) 662-4185
 www.navituseng.com

REVISION	DATE

ANTERO RESOURCES
 THIS DOCUMENT WAS PREPARED FOR:
 ANTERO RESOURCES
 APPALACHIAN CORP.

RECLAMATION PLAN
HINTER HEIRS NORTH
 CENTRALIZED FRESHWATER IMPOUNDMENT
 NEW MILTON DISTRICT
 DODDRIDGE COUNTY, WEST VIRGINIA

DATE: 01/21/2013
 SCALE: 1" = 50'
 SHEET 18 OF 18