

Commercial/Industrial Floodplain Development Permit

Doddridge County, WV Floodplain Management

This permit has been issued to **Dominion Hope Gas, Inc.**, and is for the approved commercial and/or industrial development project associated with this permit that impacts the FEMA-designated floodplain and/or floodway of Doddridge County, WV, pursuant to the rules and regulations established by all applicable Federal, State and local laws and ordinances, including the Doddridge County Floodplain Ordinance. This permit must be posted at the site of work as to be clearly visible, and must remain posted during entirety of development.

Permit #:14-188

Date Approved: 05/02/2014

Expires: 05/02/2015

Issued to: Dominion Hope Gas, Inc

POC:

Company Address: 48 Columbia Blvd; Clarksburg, WV 26301

Project Address: Dotson Run, Central District

Firm: 54017C0115C

Lat/Long:

Purpose of development: Pipeline replacement

Issued by: Edwin L. "Bo" Wriston, Doddridge County FPM (or designee)

Date: 02May2014

For additional information regarding this permit, please contact
Doddridge County Floodplain Manager at 304.873.2631, or via email at
doddridgecountyfpm@gmail.com
118 East Court Street; West Union, WV 26456

7013 2250 0001 6914 8599

U.S. Postal Service TM
CERTIFIED MAIL TM RECEIPT
(Domestic Mail Only; No Insurance Coverage Provided)

For delivery information visit our website at www.usps.com

OFFICIAL USE

Postage	\$.48
Certified Fee	3.30
Return Receipt Fee (Endorsement Required)	2.70
Restricted Delivery Fee (Endorsement Required)	
Total Postage & Fees	\$ 6.48

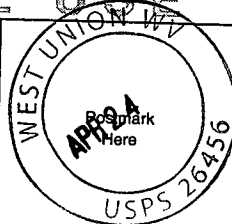

#14-188

Sent To Alvadore McCloy, Jr.
 Street, Apt. No.,
 or PO Box No. Rt. 1 Box 310
 City, State, ZIP+4 Greenwood, WV 26415

PS Form 3800, August 2006 See Reverse for Instructions

7013 2250 0001 6914 8490

U.S. Postal Service TM
CERTIFIED MAIL TM RECEIPT
(Domestic Mail Only; No Insurance Coverage Provided)

For delivery information visit our website at www.usps.com

OFFICIAL USE

Postage	\$.48
Certified Fee	3.30
Return Receipt Fee (Endorsement Required)	2.70
Restricted Delivery Fee (Endorsement Required)	
Total Postage & Fees	\$ 6.48



#14-188

Sent To Chester & Berna Ankrom
 Street, Apt. No.,
 or PO Box No. 132 Rocket Dr.
 City, State, ZIP+4 Greenwood WV 26415

PS Form 3800, August 2006 See Reverse for Instructions

SENDER: COMPLETE THIS SECTION

- Complete items 1, 2, and 3. Also complete item 4 if Restricted Delivery is desired.
- Print your name and address on the reverse so that we can return the card to you.
- Attach this card to the back of the mailpiece, or on the front if space permits.

1. Article Addressed to: # 14-188

Alvadore McCloy, Jr.
Rt 1 Box 310
Greenwood, WV 26415

2. Article Number

(Transfer from service label)

7013 2250 0001 6914 8599

COMPLETE THIS SECTION ON DELIVERY

A. Signature

X *Alvadore McCloy Jr.* Agent
 Addressee

B. Received by (Printed Name)

Alvadore McCloy

C. Date of Delivery

*4/28/14*D. Is delivery address different from item 1? Yes

If YES, enter delivery address below:

 No

3. Service Type

 Certified Mail® Priority Mail Express™ Registered Return Receipt for Merchandise Insured Mail Collect on Delivery

4. Restricted Delivery? (Extra Fee)

 Yes

UNITED STATES POSTAL SERVICE

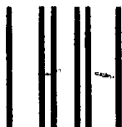

First-Class Mail
Postage & Fees Paid
USPS
Permit No. G-10

25 APR 14

• Sender: Please print your name, address, and ZIP+4® in this box •

FILED

2014 APR 28 AM 11:33

DOUGLASS COUNTY, WV

Braxton
Dodge County FloodPlain MGT
118 West Court St., Suite 102
West Union, WV 26456

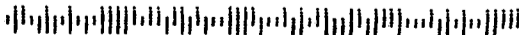

SENDER: COMPLETE THIS SECTION

- Complete items 1, 2, and 3. Also complete item 4 if Restricted Delivery is desired.
- Print your name and address on the reverse so that we can return the card to you.
- Attach this card to the back of the mailpiece, or on the front if space permits.

1. Article Addressed to: #14-188
 Chester & Berna Ankrom
 132 Rocket Dr.
 Greenwood, WV 26415

2. Article Number
(Transfer from service label)

7013 2250 0001 6914 8490

COMPLETE THIS SECTION ON DELIVERY

A. Signature

X Berna K. Ankrom Agent
 Addressee

B. Received by *(Printed Name)*

Berna K. Ankrom Agent
 Addressee

C. Date of Delivery

4/25/14

D. Is delivery address different from item 1? Yes

If YES, enter delivery address below: No

3. Service Type

- Certified Mail® Priority Mail Express™
- Registered Return Receipt for Merchandise
- Insured Mail Collect on Delivery

4. Restricted Delivery? *(Extra Fee)*

Yes

UNITED STATES POSTAL SERVICE



First-Class Mail
Postage & Fees Paid
USPS
Permit No. G-10

WV 260

25 APR '14

• Sender: Please print your name, address, and ZIP+4® in this box •

FILED

2014 APR 28 AM 11:37

Bo Wilson
Dorridge County FloodPlain MGT
118 East Court St., Suite 102
West Union, WV 26456

DEBRA A. WILSON
COUNTY CLERK
DORRIDGE COUNTY, WV



Environment & Archaeology LLC
Returned to Sharon Brown.

4/15/14

17393

Environment & Archaeology, LLC
221 Main Street
Florence, KY 41042
(859) 746-1778

J.P. Morgan
JPMorgan Chase Bank, N.A.
Columbus, Ohio
25-3-440

EZShieldSM Check Fraud
Protection for Business

3/26/2014

PAY TO THE ORDER OF **Doddridge County Commission**

\$ **1,000.00

One Thousand and 00/100 *****
DOLLARS

MEMO **Floodplain permit, DHG M-1657**

AUTHORIZED SIGNATURE

Security features. Details on back.

⑈017393⑈ ⑆044000037⑆ 617990304⑈

Environment & Archaeology, LLC

17393

Doddridge County Commission

Date	Type	Reference	Original Amt.	Balance Due	3/26/2014	Discount	Payment
3/26/2014	Bill		1,000.00	1,000.00			1,000.00
					Check Amount		1,000.00

Bank One Checking Floodplain permit, DHG M-1657 1,000.00

Replaced w/ check 17423
for 500.00

Doddridge County, West Virginia

RECEIPT NO: 1964

DATE: 2014/04/15

FROM: ENVIRONMENT & ARCHAEOLOGY LLC AMOUNT: \$ 500.00

FIVE HUNDRED DOLLARS AND 00 CENTS

FOR: DOMINION HOPE GAS
M-1657 PIPELINE REPLACEMENT

00000017423 FP-BUILDING PERMITS

020-318

TOTAL: \$500.00

MICHAEL HEADLEY

SHERIFF & TREASURER

MEC

CLERK

Customer Copy

TRANSMITTAL FORM

TO: Ms. Lorena Slater
Doddridge County Clerk's Office
118 East Court Street, Room 102
West Union, West Virginia 26456

FROM: Ms. Sharon Brown
Environment & Archaeology, LLC
221 Main Street
Florence, KY 41042

DATE: April 9, 2014

PROJECT: Dominion Hope Gas, Inc. – 2014 M-1657 Pipeline Replacement Project

RE: \$500.00 Replacement Check (\$1,000.00 check submitted originally) for the permit review fee associated with the Floodplain Development Permit

2014 APR 15 PM 2:34
BETH A. ROGERS
COUNTY CLERK
DODDRIDGE COUNTY, WV

FILED

Legal Advertisement:
Doddridge County
Floodplain Permit Application

Please take notice that on the 15th day of April, 2014

DOMINION HOPE GAS INC. #14-188

filed an

application for a Floodplain Permit to develop land located at or
about: **SURFACE OWNERS: ALVADORE MCCLOY, JR. GREENWOOD,
DOTSON RUN, PARCEL 42 & 43, DEED BOOK 173/634**

The Application is on file with the Clerk of the County Court and
may be inspected or copied during regular business hours.

Any interested persons who desire to comment shall present
the same in writing by **May 5, 2014.**

Delivered to the:
Clerk of the County Court
118 E. Court Street, West Union, WV 26456.

Beth A Rogers, Doddridge County Clerk
Edwin L. "Bo" Wriston. Doddridge County Flood Plain Manager

*
* TRANSACTION REPORT *
*
* APR-15-2014 TUE 03:54 PM *
*
* FOR: DODDRIDGE CO. CLERK 304 873 1840 *
*
* SEND *
*
* DATE START RECEIVER TX TIME PAGES TYPE NOTE M# DP *
* APR-15 03:54 PM 3048731600 25" 1 FAX TX OK 980 *
*
* TOTAL : 25S PAGES: 1 *
*

Legal Advertisement:
Doddridge County
Floodplain Permit Application

Please take notice that on the 15th day of April, 2014
DOMINION HOPE GAS INC. #14-188
filed an
application for a Floodplain Permit to develop land located at or
about: **SURFACE OWNERS: ALVADORE MCCLOY, JR. GREENWOOD,
DOTSON RUN, PARCEL 42 & 43, DEED BOOK 173/634**
The Application is on file with the Clerk of the County Court and
may be inspected or copied during regular business hours.
Any interested persons who desire to comment shall present
the same in writing by **May 5, 2014.**

Delivered to the:
Clerk of the County Court
118 E. Court Street, West Union, WV 26456.

Beth A Rogers, Doddridge County Clerk
Edwin L. "Bo" Wriston. Doddridge County Flood Plain Manager

14-188

Dominion Hope Gas, Inc.
48 Columbia Boulevard
Clarksburg, WV 26301



March 25, 2014

BY OVERNIGHT (OR EXPRESS) MAIL

Ralph Sandora, Jr.
Doddridge County Clerk
118 East Court Street, Room 102
West Union, West Virginia 26456

**RE: Dominion Hope Gas, Inc. - 2014 M-1657 Pipeline Replacement Project
(Project)
Floodplain Development Permit Application
Central District, Doddridge County, West Virginia**

2014 MAR 31 AM 11:39
BETH A. ROGERS
COUNTY CLERK
DODDRIDGE COUNTY, WV

FILED

Dear Mr. Sandora:

Dominion Hope Gas, Inc. (DHG) has enclosed for your review the Doddridge County Flood Plain Permit Application for the 2014 M-1657 Pipeline Replacement Project (Project) in Central District, Doddridge County, West Virginia. The western-most portion of the proposed Project is mapped within the Dotson Run floodplain (Figure 1 and 2).

DHG is proposing to perform the following activities with the FEMA-mapped 100-year floodplain:

1. Replace approximately 75 feet of three (3)-inch diameter pipeline under Dotson Run (Stream 1) utilizing a horizontal directional drilling method, as well as install approximately 65 feet of new pipeline within the floodplain in a new pipeline alignment.
2. Install approximately 135-feet of new eight (8)-inch diameter plastic pipeline within the floodplain of Dotson Run.
3. Install a Wet Crossing within Stream 2, which is associated with the pipeline replacement activities.
4. Utilize Access Road 1 which consists of an existing gravel drive. No modifications will be made to Access Road 1.

All workspaces within the floodplain will be restored to original grades, contours, and vegetation types upon the completion of construction activities. No above-ground features are associated with the proposed Project; therefore, Section 6 – As Built Elevations is not applicable to the Project.

2014 M-1657 Pipeline Replacement Project
Floodplain Development Permit Application
Page 2

Please find enclosed the following documentation:

- Floodplain Development Permit Application
- \$1,000.00 permit review fee
- Maps of the Project area illustrating the 100-year floodplain
- Typical Construction Drawings applicable to the Project

If you have any questions concerning the application or need additional information, please contact Greg Eastridge at (330) 664-2576 or Gregory.K.Eastridge@dom.com. Please direct your response to:

Greg Eastridge
Environmental Specialist
320 Springside Drive, Suite 320
Akron, Ohio 44333

Sincerely,



Lisa C. Moerner
Director, Environmental Sustainability and Gas Environmental Services

Enclosures

cc: Greg Eastridge

#14-188
Dominion Hope Gas
- 2014 M-1657 P/L
Replacement

DODDRIDGE COUNTY
FLOODPLAIN DEVELOPMENT PERMIT APPLICATION

SECTION 1: GENERAL PROVISIONS (APPLICANT TO READ AND SIGN)

1. No work may start until a permit is issued.
2. The permit may be revoked if any false statements are made herein.
3. If revoked, all work must cease until permit is re-issued.
4. Development shall not be used or occupied until a Certificate of Compliance is issued.
5. The permit will expire if no work is commenced within six months of issuance.
6. Applicant is hereby informed that other permits may be required to fulfill local, state, and federal requirements.
7. Applicant hereby gives consent to the Floodplain Administrator/Manager or his/her representative to make inspections to verify compliance.
8. I THE APPLICANT CERTIFY THAT ALL STATEMENTS HEREIN AND IN ATTACHMENTS TO THIS APPLICATION ARE, TO THE BEST OF MY KNOWLEDGE TRUE AND ACCURATE.

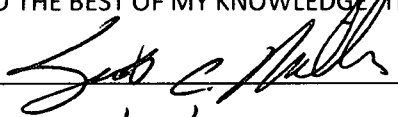
APPLICANT'S SIGNATURE 
 DATE 3/25/2014

SECTION 2: PROPOSED DEVELOPMENT (TO BE COMPLETED BY APPLICANT).

IF THE APPLICANT IS NOT A NATURAL PERSON, THE NAME, ADDRESS, AND TELEPHONE NUMBER OF A NATURAL PERSON WHO SHALL BE APPOINTED BY THE APPLICANT TO RECEIVE NOTICE PURSUANT TO ANY PROVISION OF THE CURRENT DODDRIDGE COUNTY FLOODPLAIN ORDINANCE.

APPLICANT'S NAME: Scott Miller
 ADDRESS: 48 Columbia Boulevard, Clarksburg, WV 26301
 TELEPHONE NUMBER: Contact: Greg Eastridge (330) 664-2576

CONTRACTOR NAME: D&M Contracting, Inc.
 ADDRESS: 1868 Lions Club Road New Alexandria, PA 15670
 TELEPHONE # (724) 668-8775
 WV CONTRACTOR LICENCE # WV032637

ENGINEER'S NAME: Daniel Kukoly
 ADDRESS: 55 Ashby Ridge Rd Parkersburg, WV 26104
 TELEPHONE NUMBER: (304) 841-4105

PROJECT LOCATION:

NAME OF SURFACE OWNER/OWNERS (IF NOT THE APPLICANT): Alvadore McCloy, Jr.
 ADDRESS OF SURFACE OWNER/OWNERS (IF NOT THE APPLICANT):
Route 1 Box 310, Greenwood, West Virginia 26415

DISTRICT: Central District
 LAND BOOK DESCRIPTION: Parcel 42 - Dotson Run (13,982 sqft) Parcel 43 - Dotson Run (30 poles)
 DEED BOOK REFERENCE: DB 173 pg. 634

TAX MAP REFERENCE: Map 17, Parcel 42 & 43
 EXISTING BUILDINGS/USES OF PROPERTY: Residential
 NAME OF AT LEAST ONE ADULT RESIDING IN EACH RESIDENCE LOCATED UPON THE SUBJECT
 PROPERTY Alvadore McCloy, Jr.
 ADDRESS OF AT LEAST ONE ADULT RESIDING IN EACH RESIDENCE LOCATED UPON THE SUBJECT
 PROPERTY Route 1 Box 310, Greenwood, West Virginia 26415

To avoid delay in processing the application, please provide enough information to easily identify the project location.

DESCRIPTION OF WORK (CHECK ALL APPLICABLE BOXES)

A. STRUCTURAL DEVELOPMENT

ACTIVITY	STRUCTURAL TYPE
<input type="checkbox"/> New Structure	<input type="checkbox"/> Residential (1 – 4 Family)
<input checked="" type="checkbox"/> Addition – PIPELINE RELOCATION	<input type="checkbox"/> Residential (more than 4 Family)
<input type="checkbox"/> Alteration	<input type="checkbox"/> Non-residential (floodproofing)
<input type="checkbox"/> Relocation	<input type="checkbox"/> Combined Use (res. & com.)
<input type="checkbox"/> Demolition	<input checked="" type="checkbox"/> Replacement - PIPELINE
<input type="checkbox"/> Manufactured/Mobil Home	

B. OTHER DEVELOPMENT ACTIVITIES:

- Fill Mining Drilling Pipelining
- Grading
- Excavation (except for STRUCTURAL DEVELOPMENT checked above)
- Watercourse Alteration (including dredging and channel modification)
- Drainage Improvements (including culvert work)
- Road, Street, or Bridge Construction
- Subdivision (including new expansion)
- Individual Water or Sewer System
- Other (please specify)
-

C. STANDARD SITE PLAN OR SKETCH

1. SUBMIT ALL STANDARD SITE PLANS, IF ANY HAVE BEEN PREPARED (ENGINEERING PLANS MUST BE SIGNED AND SEALED).
2. IF STANDARD SITE PLANS HAVE NOT BEEN PREPARED:
 SKETCH ON A SEPARATE 8 ½ X 11 INCH SHEET OF PAPER THE SHAPE AND LOCATION OF THE LOT. SHOW THE LOCATION OF THE INTENDED CONSTRUCTION OR LAND USE INDICATING BUILDING SETBACKS, SIZE & HEIGHT. IDENTIFY EXISTING BUILDINGS, STRUCTURES OR LAND USES ON THE PROPERTY.
3. SIGN AND DATE THE SKETCH.

ACTUAL TOTAL CONSTRUCTION COSTS OF THE COMPLETE DEVELOPMENT/ PROPOSED CONSTRUCTION PROJECT WITHIN THE FLOODPLAIN \$ 35,179.17

D. ADJACENT AND/OR AFFECTED LANDOWNERS:

1. NAME AND ADDRESS OF ALL OWNERS OF SURFACE TRACTS ADJACENT TO THE AREA OF THE SURFACE TRACT (UP & DOWN STREAM) UPON WHICH THE PROPOSED ACTIVITY WILL OCCUR AND ALL OTHER SURFACE OWNERS UP & DOWN STREAM) WHO OWN PROPERTY THAT MAY BE AFFECTED BY FLOODING AS IS DEMONSTRATED BY A FLOODPLAIN STUDY OR SURVEY (IF ONE HAS BEEN COMPLETED.

NAME: CHESTER S. & BERNA K. ANKROM
ADDRESS: 132 ROCKET DR
GREENWOOD, WV 26415

NAME: WVDOH
ADDRESS: CHARLESTON, WV

NAME: _____
ADDRESS: _____

NAME: _____
ADDRESS: _____

2. NAME AND ADDRESS OF AT LEAST ONE ADULT RESIDING IN EACH RESIDENCE LOCATED UPON ANY ADJACENT PROPERTY AT THE TIME THE FLOODPLAIN PERMIT APPLICATION IS FILED AND THE NAME AND ADDRESS OF AT LEAST ONE ADULT RESIDING IN ANY HOME ON ANY PROPERTY THAT MAY BE AFFECTED BY FLOODING AS IS DEMONSTRATED BY A FLOODPLAIN STUDY OR SURVEY.

NAME: Same as Above
ADDRESS: _____

NAME: _____
ADDRESS: _____

E. CONFIRMATION FORM

THE APPLICANT ACKNOWLEDGES, AGREES, AND CONFIRMS THAT HE/IT WILL PAY WITHIN 30 DAYS OF RECEIPT OF INVOICE BY THE COUNTY FOR ALL EXPENSES RELATIVE TO THE PERMIT APPLICATION PROCESS GREATER THAN THE REQUIRED DEPOSIT FOR EXPENSES INCLUDING:

- (A) PERSONAL SERVICE OF PROCESS BY THE DODDRIDGE COUNTY SHERIFF AT THE RATES PERMITTED BY LAW FOR SUCH SERVICE.
- (B) SERVICE BY CERTIFIED MAIL RETURN RECEIPT REQUESTED.
- (C) PUBLICATION.
- (D) COURT REPORTING SERVICES AT ANY HEARINGS REQUESTED BY THE APPLICANT.
- (E) CONSULTANTS AND/OR HEARING EXPERTS UTILIZED BY DODDRIDGE COUNTY FLOODPLAIN ADMINISTRATOR/MANAGER OR FLOODPLAIN APPEALS BOARD FOR REVIEW OF MATERIALS AND/OR TESTIMONY REGARDING THE EFFICACY OF GRANTING OR DENYING THE APPLICANT'S FLOODPLAIN PERMIT.

NAME (PRINT): Scott C. Miller

SIGNATURE: Scott C. Miller

DATE: 3/25/2014

After completing SECTION 2, APPLICANT should submit form and fees to Clerk of Doddridge County Court or his/her representative for review.

SECTION 3: FLOODPLAIN DETERMINATION (to be completed by Floodplain Administrator/Manager or his/her representative)

THE PROPOSED DEVELOPMENT:

THE PROPOSED DEVELOPMENT IS LOCATED ON:

FIRM Panel: _____

Dated: _____

- Is NOT located in a Specific Flood Hazard Area (Notify applicant that the application review is complete and NO FLOODPLAIN DEVELOPMENT PERMIT IS REQUIRED).

- Is located in Special Flood Hazard Area.
FIRM zone designation _____
100-Year flood elevation is _____ NGVD .
Stream name _____
Profile # _____

- Unavailable

- The proposed development is located in a floodway.

- See section 4 for additional instructions.

SIGNED _____

DATE _____

SECTION 4: ADDITIONAL INFORMATION REQUIRED FOR DEVELOPMENT IN SPECIAL FLOOD HAZARD AREA (To be completed by Floodplain Administrator/Manager or his/her representative)

The applicant must submit the documents checked below before the application can be processed.

- A plan showing the location of all existing structures, water bodies, adjacent roads and proposed development.

- Development plans, drawn to scale, and specifications, including where applicable: details for anchoring structures, storage tanks, proposed elevation of lowest floor, (including basement or crawl space), types of water resistant materials used below the first floor, details of flood proofing of utilities located below the first floor and details of enclosures below the first floor.
Also _____

- Subdivision or other development plans (If the subdivision or development exceeds 10 lots or 2 acres, whichever is the lesser, the applicant must provide 100-year flood elevations if they are not otherwise available).

- Plans showing the extent of watercourse relocation and/or landform alterations.

- Top of new fill elevation _____ Ft. NGVD.
For floodproofing structures applicant must attach certification from registered engineer or architect.
- Certification from a registered engineer that the proposed activity in a regulatory floodway will not result in any increase in the height of the 100-year flood. A copy of all data and calculations supporting this finding must also be submitted.
- Manufactured homes located in a Flood Hazard Area must have a West Virginia Contractor's License and a Manufactured Home Installation License as required by the Federal Emergency Management Agency (FEMA).
- Other: _____

SECTION 5: PERMIT DETERMINATION (To be completed by Floodplain Administrator/Manager or his/her representative)

I have determined that the proposed activity (type is or is not) in conformance with provisions of the Floodplain Ordinance adopted by the County Commission of Doddridge County on May 21, 2013. The permit is issued subject to the conditions attached to and made part of this permit.

SIGNED _____ DATE _____

If the Floodplain Administrator/Manager found that the above was not in conformance with the provisions of the Doddridge County Floodplain Ordinance and/or denied that application, the applicant may appeal.

APPEALS: Appealed to the County Commission of Doddridge County? Yes {} No
 Hearing Date: _____
 County Commission Decision - Approved Yes No

CONDITIONS: _____

SECTION 6: AS-BUILT ELEVATIONS (To be submitted by APPLICANT before Certificate of Compliance is issued).

NOT APPLICABLE

The following information must be provided for project structures. This section must be completed by a registered professional engineer or a licensed land surveyor (or attach a certification to this application).

COMPLETE 1 OR 2 BELOW:

- 1 Actual (As-Built) Elevation of the top of the lowest floor (including basement or crawl space is _____ FT. NGVD.
- 2 Actual (As Built) elevation of floodproofing is _____ FT. NGVD.

Note: Any work performed prior to submittal of the above information is at risk of the applicant.

SECTION 7: COMPLIANCE ACTION (To be completed by the Floodplain Administrator/Manager or his/her representative).

The Floodplain Administrator/Manager or his/her representative will complete this section as applicable based on inspection of the project to ensure compliance with the Doddridge County Floodplain Ordinance.

INSPECTIONS:

DATE: _____ BY: _____
DEFICIENCIES? Y/N

COMMENTS _____

SECTION 8: CERTIFICATE OF COMPLIANCE (To be completed by Floodplain Administrator/Manager or his/her representative).

Certificate of Compliance issued: DATE: _____ BY: _____

**CERTIFICATE OF COMPLIANCE
FOR DEVELOPMENT IN SPECIAL FLOOD HAZARD AREA (OWNER MUST RETAIN)**

PERMIT NUMBER: _____
PERMIT DATE: _____

PURPOSE –

CONSTRUCTION LOCATION: _____

OWNER'S ADDRESS: _____

THE FOLLOWING MUST BE COMPLETED BY THE FLOODPLAIN ADMINISTRATOR/MANAGER OR HIS/HER AGENT.

COMPLIANCE IS HEREBY CERTIFIED WITH THE REQUIREMENT OF THE FLOODPLAIN ORDINANCE ADOPTED BY THE COUNTY COMMISSION OF DODDRIDGE COUNTY ON MAY 21, 2013.

SIGNED _____ DATE _____

FILED

2014 MAR 31 AM 11:39
BETH A. ROGERS
COUNTY CLERK
DODDRIDGE COUNTY, WV

ATTACHMENT 1

**DODDRIDGE COUNTY FLOODPLAIN
DEVELOPMENT PERMIT APPLICATION AND FEE PAYMENT**

ATTACHMENT 2
FEMA FLOODPLAIN MAP

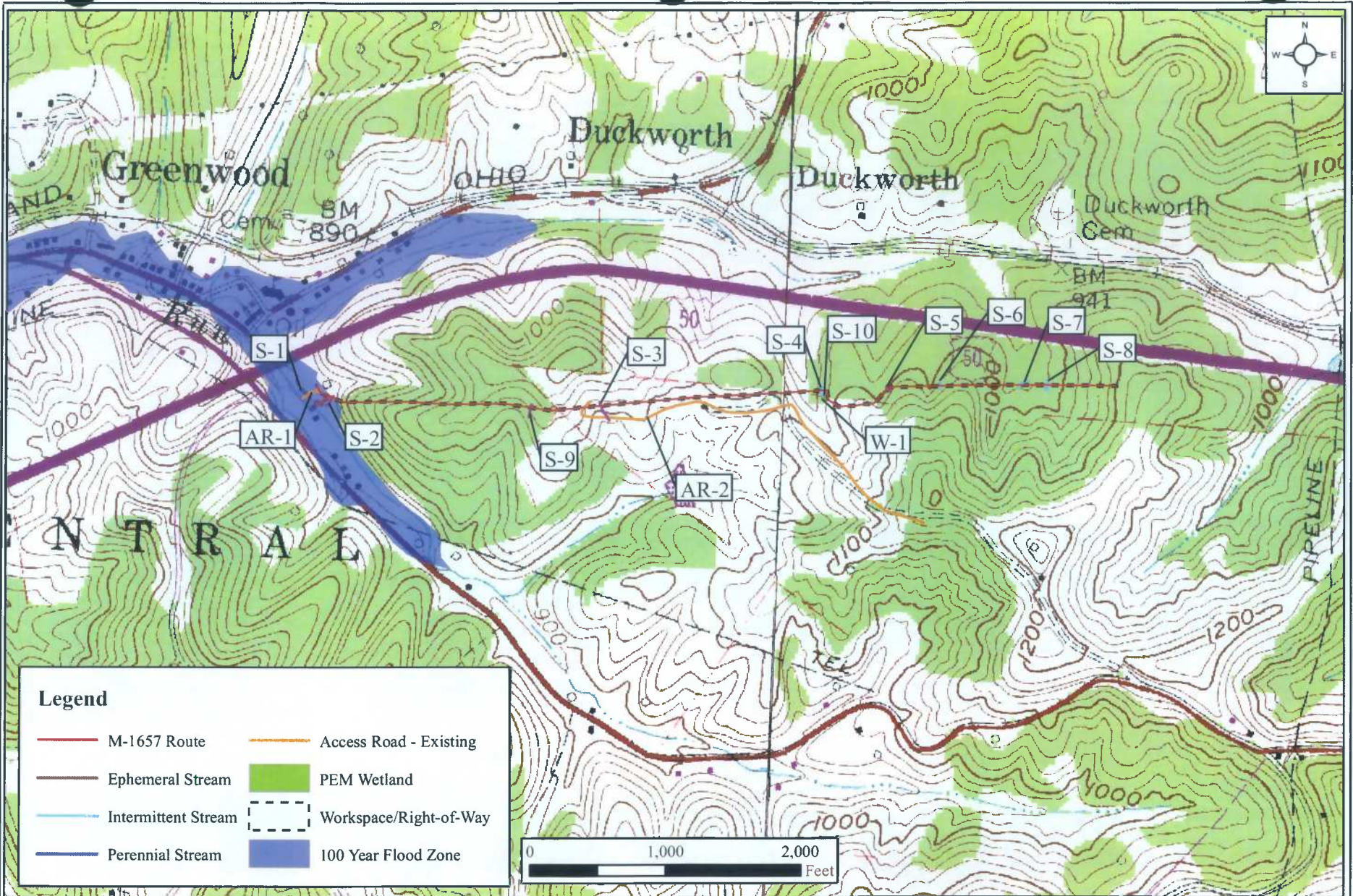

Figure 1

Dominion Hope Gas, Inc.
 2014 M-1657 Pipeline Relocation Project
 Doddridge County, West Virginia

USGS 7.5' Topographic Map with FEMA Overlay
 Pennsboro and West Union, WV Quadrangles
 1:12,000
 Environment & Archaeology, LLC



Figure 2	Dominion Hope Gas, Inc. 2014 M-1657 Pipeline Relocation Project Doddridge County, West Virginia	Aerial Map with FEMA Overlay - Floodplain Area Aerial Provided by ESRI Map Services 1:2,400 Environment & Archaeology, LLC
----------	---	---

ATTACHMENT 3
TYPICAL CONSTRUCTION DRAWINGS

3.27 - SILT FENCE

Introduction

A temporary sediment barrier consisting of a synthetic filter fabric stretched across and attached to supporting posts and entrenched. Used to intercept and detain small amounts of sediment from disturbed areas during construction operations in order to prevent sediment from leaving the site.

No sediment control device is misused more than silt fence (with the possible exception of hay bales). Much of the silt fence used in West Virginia is not installed properly. The device does not work if:

1. not entrenched a minimum of 4 inches.
2. not placed on the contour-perpendicular to the flow of the water.
3. installed in areas of concentrated flows.
4. installed to contain sediment from too large of an area.
5. little or no maintenance is performed on it.

Silt fence does not actually filter sediment from muddy water. In field conditions silt fence acts as a barrier to the flow of water, like a dam, reducing the energy of the water, which causes the suspended material to settle out. It is because of the low permeability of the fabric that silt fence is limited to small drainage areas

Installing silt fence is very labor intensive. It is usually installed by hand and accumulated sediment must be removed and disposed of by hand. In many scenarios, installing a diversion and sediment trap would be more effective and less expensive than using silt fence. In addition, the NPDES permit requires that a sediment trap or basin be installed whenever possible.

Conditions Where Practice Applies

1. Below disturbed areas where erosion would occur in the form of sheet and small rill erosion.
2. Where the size of the drainage area is no more than one-quarter acre per 100 feet of silt fence length; the maximum gradient above the barrier should be less than 2:1.
3. Silt fence will not be used in areas where rock or some other hard surface prevents the full and uniform anchoring of the barrier.
4. Silt fence should NEVER be installed in streams or swales or in any area where there is a reasonable chance of concentrated flow. In areas where concentrated flows can be expected, use diversions and sediment traps and /or sediment basins. In ditches or swales rock check dams should be used in place of silt fence.

Design Criteria

1. No formal design is required. An effort should be made to locate silt fence at least 5 feet to 10 feet beyond the toe of slope.

2. Silt fence should be limited to situations in which only sheet is expected.
3. Silt fence should be installed prior to major soil disturbance.
4. Silt fence should be placed across the bottom of a slope along a line of uniform elevation (ALWAYS perpendicular to the direction of flow).
5. Any time a section of silt fence is knocked down by concentrated flows the silt fence will be replaced with a diversion and sediment trap or super silt fence.

Construction Specifications

Materials

1. Synthetic filter fabric shall be a pervious sheet of propylene, nylon, polyester or ethylene yarn and shall be certified by the manufacturer or supplier as conforming to the requirements noted in WV DOT DOH Specifications or the GEOTEXTILE section.
2. Synthetic filter fabric shall contain ultraviolet ray inhibitors and stabilizers to provide a minimum of 6 months expected usable construction life at a temperature range of 0 to 120 degrees Fahrenheit.
3. If wooden stakes are utilized for silt fence construction, they must be a minimum of 2" x 2" when oak is used and 2" x 4" when pine is used. Wooden stakes should have a minimum length of 5 feet.
4. If steel posts (standard "U" or "T" section) are utilized for silt fence construction, they must have a minimum weight of 1.33 pounds per linear foot and should have a minimum length of 5 feet.

Installation

1. The height of a silt fence shall be a minimum of 16 inches above the original ground surface and shall not exceed 34 inches above ground elevation.
2. The filter fabric shall be purchased in a continuous roll cut to the length of the barrier to avoid the use of joints. When joints are unavoidable, the silt fence shall be spliced together only at a support post, by twisting the last post of each run around the other, and securely sealed. (see drawing)
3. A trench shall be excavated approximately 4 inches wide and 4 inches deep on the upslope side of the proposed location of the measure.
4. The filter fabric shall be fastened securely to the upslope side of the posts using one inch long (minimum) heavy-duty wire staples or tie wires and eight inches of the fabric shall be extended into the trench. The fabric shall not be stapled to existing trees. The most common type of silt fence has the stakes attached to the fabric at the factory.
5. The 4-inch by 4-inch trench shall be backfilled and the soil compacted over the filter fabric.

Maintenance

6. Silt fence shall be removed when it has served its useful purpose, but not before the upslope area has been permanently stabilized.
 7. Turn the end of a run of Silt Fence slightly uphill to prevent runoff from going around the end.
1. Silt fences shall be inspected immediately after each rainfall of 0.5 inch or greater and at least daily during prolonged rainfall or once a week. Any required repairs or maintenance shall be made immediately.
 2. Close attention shall be paid to the repair of damaged silt fence resulting from end runs and undercutting. If the fence is not installed on the contour (perpendicular to the flow of the water) both of these conditions can occur.
 3. Should the fabric on a silt fence decompose or become ineffective prior to the end of the expected usable life and the barrier still is necessary, the fabric shall be replaced promptly.
 4. Sediment deposits should be removed after each storm event. They must be removed when deposits reach approximately one-half the height of the barrier.
 5. If any section of silt fence is knocked down during a rain event (because it was installed in an area of concentrated flow) then other measures such as a sediment trap and diversion or super silt fence must be installed.

FIGURE 3.27.2

SILT FENCE

NOTE:
THE MAXIMUM LENGTH
OF SLOPE ABOVE
A ROW OF SILT
FENCE IS 110'

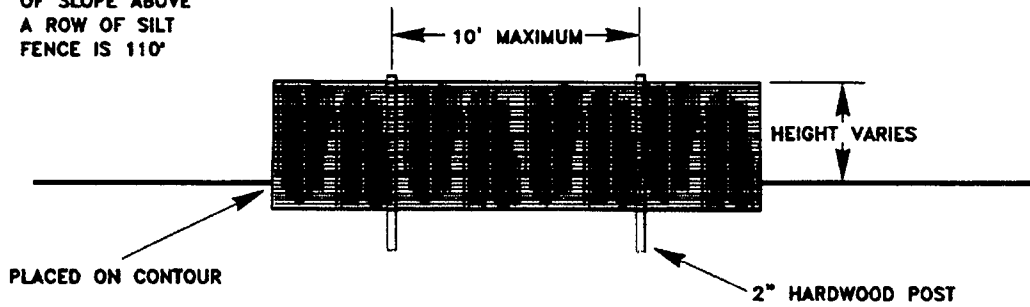

FRONT ELEVATION

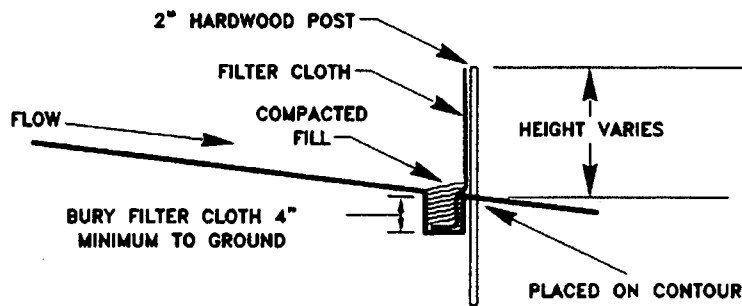

SIDE ELEVATION



TOP VIEW

FIGURE 3.27.1

PLACEMENT OF SILT FENCE

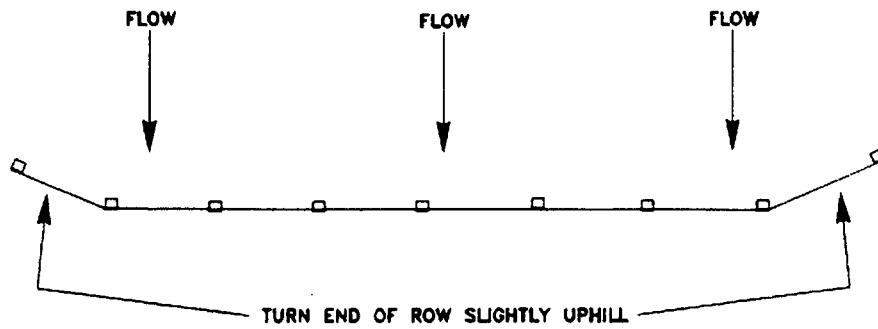
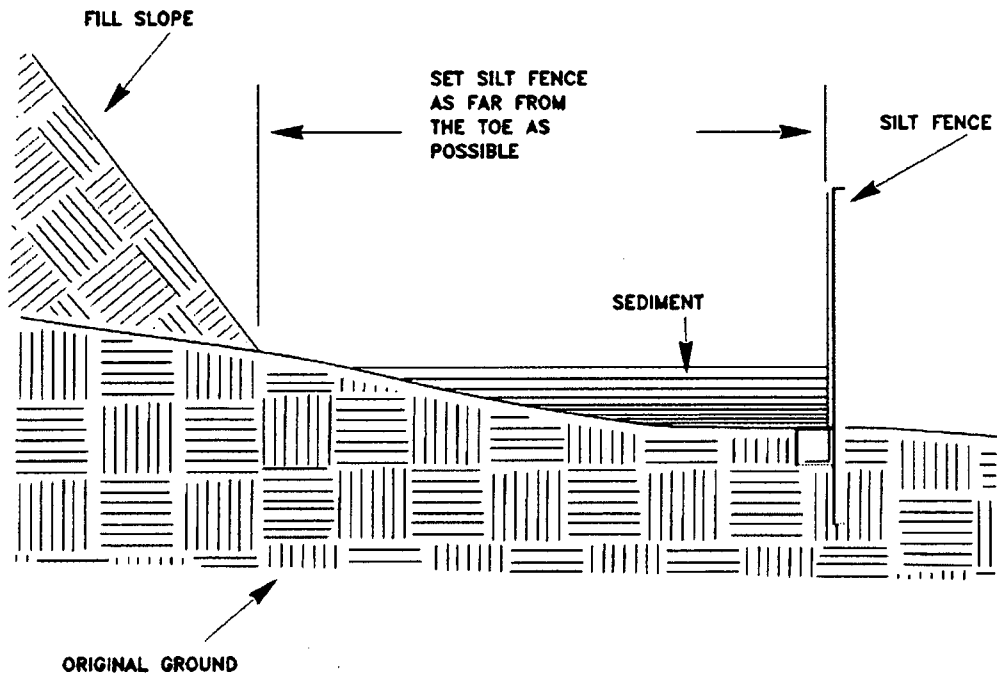

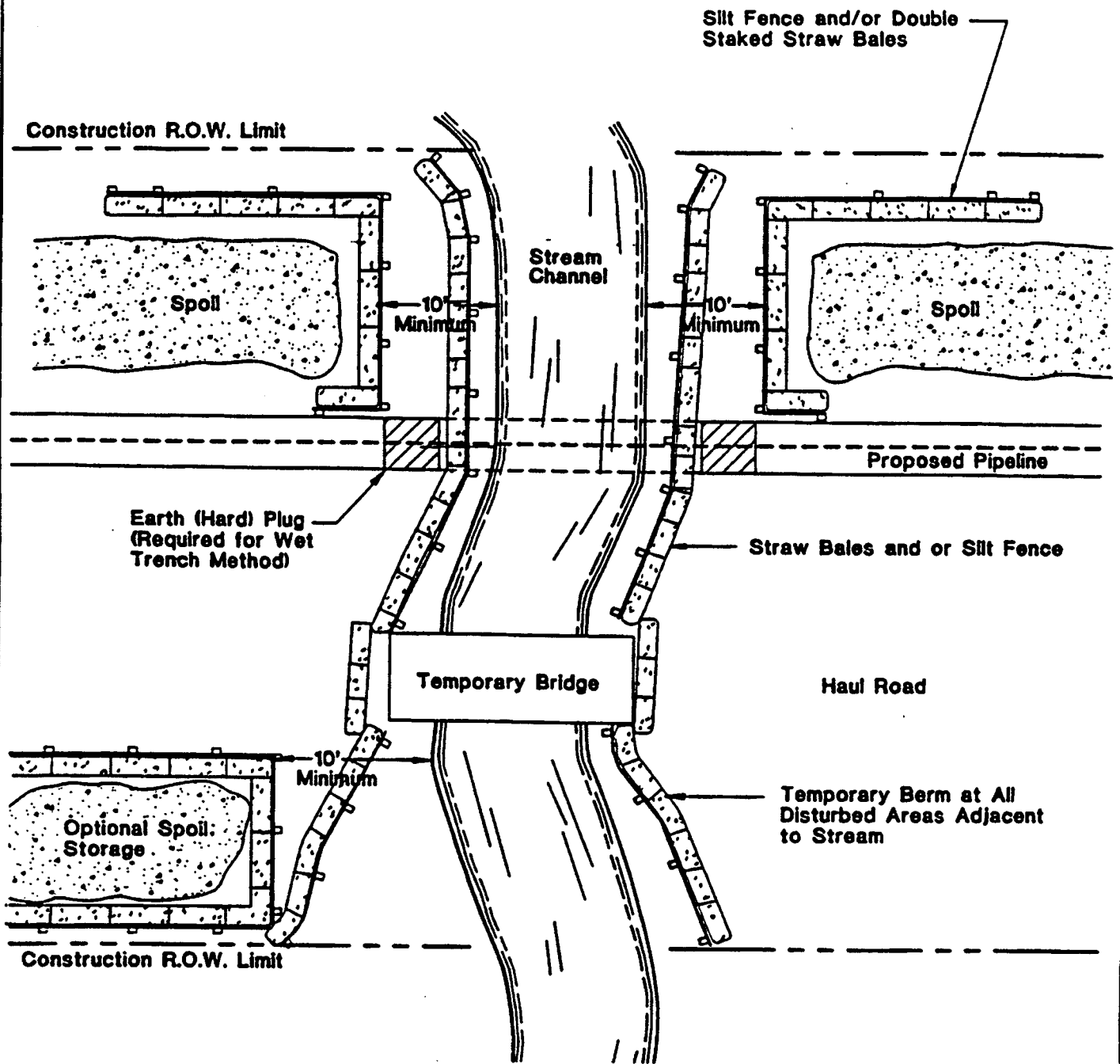

PLAN VIEW
(NOT TO SCALE)

NOTES

1. Bridge shall be removed as described in Section 3.4.3
2. Remove dirt from bridge and place in soil containment area.
3. Additional information included on other drawings or in state permits.



DominionSM

Dominion Transmission, Inc.

Typical Erosion and Sediment Control for Stream Crossings

Scale Not to scale
Created By T. Carter
Date 09/15/08
File Name Drawing ESCP-018

DRAWING
ESCP
018

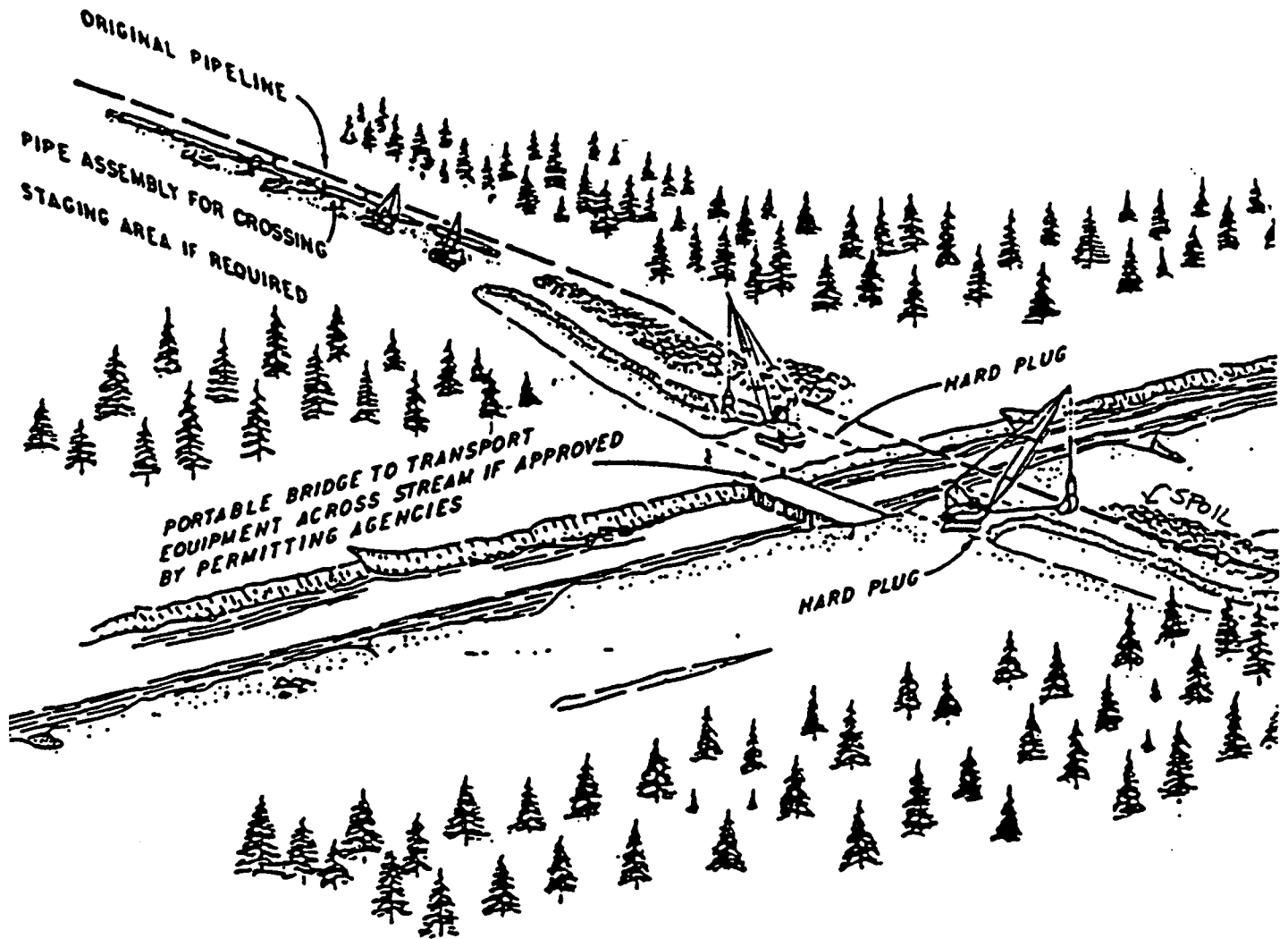

NOTES:

1. PORTABLE BRIDGE INSTALLED ACROSS STREAM OR RIVER.
2. HARD PLUG LEFT ON EACH BANK TO PREVENT STREAMFLOW INTO TRENCH.
3. PIPE FOR CROSSING ASSEMBLED AWAY FROM STREAM.
4. DITCH PLUG CONSTRUCTED BEHIND HARD PLUG.



DominionSM

Dominion Transmission, Inc.

Wet Trench Method

Scale Not to scale
 Created By T. Carter
 Date 09/15/08
 File Name Drawing ESCP-022

DRAWING
ESCP
022

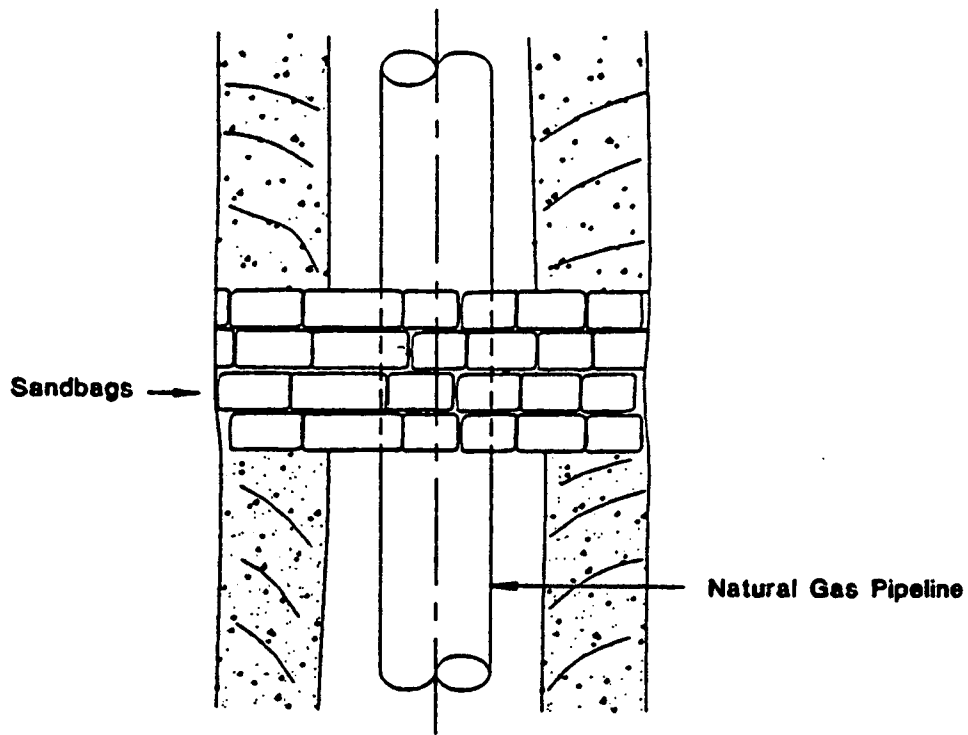

PLAN VIEW
(NOT TO SCALE)

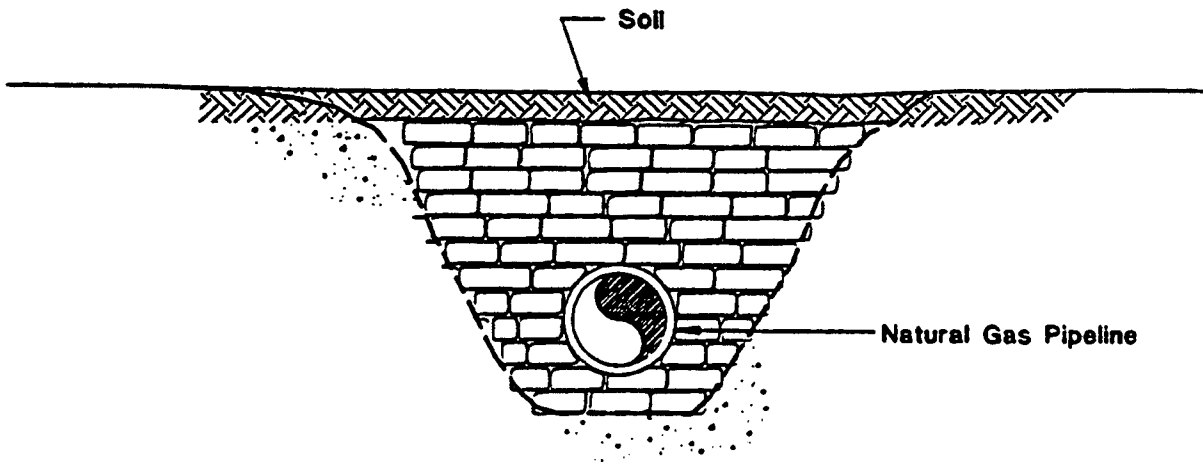

PROFILE VIEW
(NOT TO SCALE)

NOTES

1. Bags will not be filled with topsoil.
2. Addition information included on other drawings.



DominionSM

Dominion Transmission, Inc.

Trench Breaker

Scale Not to scale

Created By T. Carter

Date 09/15/08

File Name Drawing ESCP-026

DRAWING

ESCP
026

PUBLIC LAND CORPORATION
STREAM ACTIVITY APPLICATION

1. Name of Applicant: <u>Hope Gas, Inc., d/b/a Dominion Hope</u> (Landowner)
2. Date: <u>01/27/2014</u>
3. Complete mailing address of applicant: <u>48 Columbia Blvd., Clarksburg, WV 26301</u> Telephone Number: <u>304-625-6322</u> Fax Number: <u>304-625-6320</u> E-Mail Address: <u>denise.a.trent@dom.com</u>
4. Name, address, telephone number, and title of applicant's authorized agent (i.e. contractor employed by landowner): <u>Denise A. Trent Poling, Land Services Coordinator</u>
Please <input checked="" type="checkbox"/> if you want the approval sent to the agent <input checked="" type="checkbox"/>
5. Describe the proposed activity, its purpose and intended use after completion, type of equipment to be used in the stream, amount of material to be dredged (if any), plan for disposing of dredged materials, length of stream/bank to be worked or type and size of structure to be placed in the stream (i.e. length and width of bridge, diameter and length of culvert). One copy of a map (topographical or detailed, hand-drawn) showing exact location of the work site (enabling Officials to locate site) must accompany this application, and all other information that may be important to this application.
<p>*See attached plat</p> <p>P-14-VI/9-179 LS#2</p> <p>Received JAN 2014 Land & Stream</p>
(if additional space is required, continue on a separate sheet)

6. Please <input checked="" type="checkbox"/> the proposed use:		
Private: _____ (person use)	Public: _____ (Government Agency)	Commerical: <u>X</u> (Business)
7. Location where proposed activity exists or will occur: <u>Dotson Run</u>		
Name of Water Way (if unnamed or unknown tributary, provide the stream that is flows into)		
<u>Doddridge</u>	<u>Central</u>	<u>Greenwood</u>
County	District (taxable)	Closest City or Town
8. Date activity is proposed to commence: <u>02/17/2014</u>		
Date activity is expected to be complete: <u>02/18/2014</u>		
9. Is any portion of the activity for which authorization is sought now complete? Yes _____ No <u>X</u> (If the answer is "Yes", give reasons in Section 5 including month and year the activity was completed)		
10. Below is a list of entities that may require permits. Please list all approvals or certifications required by other Government Agencies for the above-described activity:		
Issuing agency: Corps of Engineers – (304) 399-5710 (412) 395-7170 (412) 395-7157	Type of approval: _____	
Identification No.: _____	Date of approval: _____	
Issuing agency: County Commission Flood Plain Coordinator	Type of approval: _____	
Identification No.: _____	Date of approval: _____	
Issuing agency: City Government (if in City Limits the County isn't needed)	Type of approval: _____	
Identification No.: _____	Date of approval: _____	
11. Has any agency denied approval for the activity described herein? Yes _____ No <u>X</u> (If "Yes", explain in Section 5 and/or attach a copy of the denial)		
12: If activity is a pipeline construction (that is, gas, water, or sewer) give:		
Material pipeline is made of: <u>plastic</u>		
Size of Pipeline: <u>3"</u>		
Maximum pressure of the pipeline: <u>60 psig</u>		
Please provide the appropriate line number and if a Gathering or Well Line provide the A.P.I. Well Number:		
Transmission: _____	Distribution: <u>X</u>	Gathering: _____ Well Line: _____ A.P.I. Well Number: _____
13: Application is hereby made for authorization to conduct the activities described herein. I certify that I am familiar with the information in this application, and that to the best of my knowledge and belief such information is true, complete and accurate. I further certify that I possess the authority to undertake the proposed activities.		
 Signature of Applicant or Agent		
Public Land Corporation Capitol Complex, Building 3, Room 643 1900 Kanawha Boulevard, East Charleston, West Virginia 25305-0661 Phone Number 304-558-3225 Fax Number 304-558-6048		
PLC Form 1 (6/03)		



DIVISION OF NATURAL RESOURCES
 324 Fourth Avenue, Room 200
 South Charleston WV 25303-1228
 TDD (304) 559-1439
 TDD 1-800-354-6087
 Fax (304) 558-6046
 Telephone (304) 559-3223

Earl Ray Tomblin
 Governor

Frank Jezioro
 Director

February 4, 2014

Division of Natural Resources
 LICENSE AND RIGHT OF ENTRY

Re: P-14-VW09-179

Hope Gas, Inc. dba Dominion Hope
 Attention: Denise Trent
 48 Columbia Blvd
 Clarksburg, WV 26301

Dear Ms Trent:

The Division of Natural Resources hereby grants to you for a term of 10 years, from the date hereof, a License and Right of Entry to construct, replace, cover, repair, operate, maintain, use and remove a three inch (3") plastic pipeline (M-1657) along Dotson Run, Central District, Doddridge County, West Virginia, as shown located and highlighted in red on the map attached hereto as Exhibit A

This License and Right of Entry is subject to the following terms and conditions

High Quality Streams (HQS) as listed in the West Virginia Division of Natural Resources High Quality Stream Sixth Edition published in 2001 and for any trout streams and direct tributaries of trout streams.

- Directional boring is the only method permitted during the fish spawning season. Fish spawning season for warmwater streams runs from April 1st through June 30th. Trout spawning season runs from October 1st through April 30th.
- Other dry ditch methods (pump around, flume or cofferdam) as described in WVDEP water resources manual (published 2006) on page 3.21-4 may be used outside of spawning seasons.
- Each crossing that utilizes dry ditch methods must be completed in 2 consecutive work days.

Non-high quality stream:

- Directional boring or other dry ditch methods (pump around, flume or cofferdam) as described in WVDEP water resources manual (published 2006) on page 3.21-4 may be used at all times during fish spawning season from April 1st through June 30th. This eliminates the need for spawning season restrictions.
- Crossings using methods other than directional boring. Must be completed in 1 work day.
- Only ephemeral/intermittent streams that are dry can be trenched.

Hope Gas, Inc. dba Dominion Hope
 P-14-VW09-179
 Page 2
 February 4, 2014

Bank Stabilization

All bank stabilization projects must begin immediately upon completion of utility line crossing and be completed within 24 hours of completion of utility line crossing.

Freshwater Mussels

Mussel surveys on streams with known US Fish and Wildlife listed or candidate endangered species will be required if directional boring is not an option. Contact Janet Clayton of the WVDNR Wildlife Diversity Program for information concerning mussels at 304-637-0245

For further assistance, contact the appropriate WVDNR District Fisheries Biologist.
 District 1 304-825-6787 District 2 304-822-3551 District 3 304-924-6211
 District 4 304-256-6947 District 5 304-675-0871 District 6 304-420-4550

The issuance of this License and Right of Entry by the Division of Natural Resources does not preclude the necessity to obtain a permit from the Corps of Engineers or any other state or federal permits which may be required by law, nor does this License and Right of Entry negate the need to comply with the West Virginia Water Pollution Control Act and/or the State Environmental Quality Board's administrative regulations, applicant is also responsible for determining if the proposed activity is located within an identified flood plain and it is the applicant's responsibility for contacting the local governmental agency in charge of that program and obtaining a flood plain development permit for it. This License and Right of Entry does not grant any rights or privileges, or permission to enter upon or to cross the property of any other person, nor is permission granted to remove any material that lies upon the property of any other persons. Work should be completed in as brief a period as possible and within one year from the date of this letter. In the event you fail or refuse to comply with any of the terms or conditions herein, this License and Right of Entry will be canceled and considered null and void and the Division will reject further applications.

Your check in the amount of \$75.00 is now due and payable to the Division of Natural Resources covering the (10) ten-year fee of this agreement. Your agreement will be effective upon receipt of your payment in full.

Sincerely,

 Joe T. Scarberry, Supervisor
 Office of Land and Streams

JTS:cb

attachment

pc: DNR Fish Biologist
 Mr. Mike Zeto, Environmental Enforcement
 DNR Conservation Officers



DIVISION OF NATURAL RESOURCES

324 Fourth Avenue, Room 200
South Charleston WV 25303-1228
TDD (304) 558-1439
TDD 1-800-354-6087
Fax (304) 558-6048
Telephone (304) 558-3225

Earl Ray Tomblin
Governor

Frank Jezloro
Director

April 3, 2014

Division of Natural Resources
RIGHT OF ENTRY

Re: **LS-14-VI/09-470**

Dominion Hope Gas, Inc.
48 Columbia Blvd.
Clarksburg, WV 26301-

Dear Sir or Madam:

The Division of Natural Resources hereby grants to you for a period of ten (10) years from the date hereof, a Right of Entry to install, use and maintain a timber mat crossing (2014 M-1657 Pipeline Replacement Project) at nine (9) separate locations along unnamed tributaries of Dotson Run near Greenwood in Doddridge County, West Virginia.

This Right of Entry is subject to the following terms and conditions:

1. No in stream work during the fish-spawning season (April 1-June 30).
2. Work should be completed as quickly as possible during low flows in designated work areas only.
3. Any streambed disturbance should be restricted to the immediate area. In stream use of equipment should be kept to a minimum.
4. All shore areas disturbed by this operation must be reshaped, seeded and mulched immediately upon completion of work. The prompt establishment of vegetative cover will reduce future damage from high water levels.
5. Green concrete must not be put in the stream (highly toxic to aquatic life).
6. Guidance should be obtained from NRCS (formerly SCS) and a registered engineer for the design and construction. Must allow for passage of at least ten-year year flood flow.
7. Best management practices should be followed; measures such as hay bales must be used to reduce downstream siltation.

Dominion Hope Gas, Inc.
LS-14-VI/09-470
Page 2
April 3, 2014

8. Applicant is responsible for removing debris from in and around the installation periodically to prevent stream flow obstruction.
9. Durable head walls of logs, crossties, rock, or concrete shall be constructed at both the upstream and downstream ends of crossing to prevent erosion of fill material into the stream.
10. The State's issuance of this Right-of-Entry does not provide for the applicant to work outside the requested boundaries nor does the State assume any liability for the applicant's/landowner's construction activities. By accepting this Right-of-Entry, the applicant/landowner assumes liability for any/all damages caused by this activity to both upstream and downstream landowners.

Guidelines of Best Management Practices for Sediment and Erosion Control as outlined by the Section of Water Resources, Division of Environmental Protection must be followed. Copies of those guidelines are available from the Section of Water Resources, Telephone No. (304) 926-0440.

The issuance of this Right of Entry by the Division of Natural Resources does not preclude the necessity for you to obtain a permit from the U.S. Corps of Engineers District Office, Permit Section, or any other state or federal permits which may be required by law, nor does this Right of Entry negate the need to comply with the West Virginia Water Pollution Control Act and/or the State Environmental Quality Board's administrative regulations, applicant is also responsible for determining if the proposed activity is located within an identified flood plain and it is the applicant's responsibility for contacting the local governmental agency in charge of that program and obtaining a flood plain development permit for it. This Right of Entry does not grant any rights or privileges, or permission to enter upon or to cross the property of any other person, nor is permission granted to remove any material that lies upon the property of any other persons. Work should be completed in as brief a period as possible and within one year from the date of this letter. In the event you fail or refuse to comply with any of the terms or conditions herein, this Right of Entry will be canceled and considered null and void and the Division will reject further applications.

Your payment in the amount of \$900.00 is now due and payable to the Division of Natural Resources covering the first year's annual fee of this agreement. You must notify the Division in writing with this installation has been removed. Your agreement will be effective upon receipt of your payment in full.

Sincerely,

Joe T. Scarberry, Supervisor
Office of Land and Streams

JTS:cb
pc: DNR Fish Biologist
Mr. Mike Zeto, Environmental Enforcement
DNR Conservation Officers



DIVISION OF NATURAL RESOURCES

324 Fourth Avenue, Room 200
South Charleston WV 25303-1228
TDD (304) 558-1439
TDD 1-800-354-6087
Fax (304) 558-6048
Telephone (304) 558-3225

Earl Ray Tomblin
Governor

Frank Jezloro
Director

April 3, 2014

Division of Natural Resources
LICENSE AND RIGHT OF ENTRY

Re: P-14-VI/09-471

Dominion Hope Gas, Inc.
48 Columbia Blvd.
Clarksburg, WV 26301-

Dear Sir or Madam:

The Division of Natural Resources hereby grants to you for a term of 10 years, from the date hereof, a License and Right of Entry to construct, replace, cover, repair, operate, maintain, use and remove a six inch (6") steel natural gas pipeline (2014 M-1657 Pipeline Replacement Project) at nine (9) separate locations along Dotson Run and unnamed tributaries of Dotson Run, Central District, Doddridge County, West Virginia, as shown located and highlighted in red on the map attached hereto as Exhibit A.

This License and Right of Entry is subject to the following terms and conditions:

High Quality Streams (HQS) as listed in the West Virginia Division of Natural Resources High Quality Stream Sixth Edition published in 2001 and for any trout streams and direct tributaries of trout streams:

- Directional boring is the only method permitted during the fish spawning season. Fish spawning season for warmwater streams runs from April 1st through June 30th. Trout spawning season runs from October 1st through April 30th.
- Other dry ditch methods (pump around, flume or cofferdam) as described in WVDEP water resources manual (published 2006) on page 3.21-4 may be used outside of spawning seasons.
- Each crossing that utilizes dry ditch methods must be completed in 2 consecutive work days.

Non-high quality stream:

- Directional boring or other dry ditch methods (pump around, flume or cofferdam) as described in WVDEP water resources manual (published 2006) on page 3.21-4 may be used at all times during fish spawning season from April 1st through June 30th. This eliminates the need for spawning season restrictions.
- Crossings using methods other than directional boring. Must be completed in 1 work day.
- Only ephemeral/intermittent streams that are dry can be trenched.

Dominion Hope Gas, Inc.
P-14-VI/09-471
Page 2
April 3, 2014

Bank Stabilization

All bank stabilization projects must begin immediately upon completion of utility line crossing and be completed within 24 hours of completion of utility line crossing.

Freshwater Mussels

Mussel surveys on streams with known US Fish and Wildlife listed or candidate endangered species will be required if directional boring is not an option. Contact Janet Clayton of the WVDNR Wildlife Diversity Program for information concerning mussels at 304-637-0245.

For further assistance, contact the appropriate WVDNR District Fisheries Biologist.

District 1 304-825-6787 District 2 304-822-3551 District 3 304-924-6211
District 4 304-256-6947 District 5 304-675-0871 District 6 304-420-4550

The issuance of this License and Right of Entry by the Division of Natural Resources does not preclude the necessity to obtain a permit from the Corps of Engineers or any other state or federal permits which may be required by law, nor does this License and Right of Entry negate the need to comply with the West Virginia Water Pollution Control Act and/or the State Environmental Quality Board's administrative regulations, applicant is also responsible for determining if the proposed activity is located within an identified flood plain and it is the applicant's responsibility for contacting the local governmental agency in charge of that program and obtaining a flood plain development permit for it. This License and Right of Entry does not grant any rights or privileges, or permission to enter upon or to cross the property of any other person, nor is permission granted to remove any material that lies upon the property of any other persons. Work should be completed in as brief a period as possible and within one year from the date of this letter. In the event you fail or refuse to comply with any of the terms or conditions herein, this License and Right of Entry will be canceled and considered null and void and the Division will reject further applications.

Your check in the amount of \$900.00 is now due and payable to the Division of Natural Resources covering the (10) ten-year fee of this agreement. Your agreement will be effective upon receipt of your payment in full.

Sincerely,

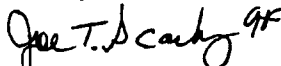

Joe T. Scarberry, Supervisor
Office of Land and Streams

JTS:cb

attachment

pc: DNR Fish Biologist
Mr. Mike Zeto, Environmental Enforcement
DNR Conservation Officers

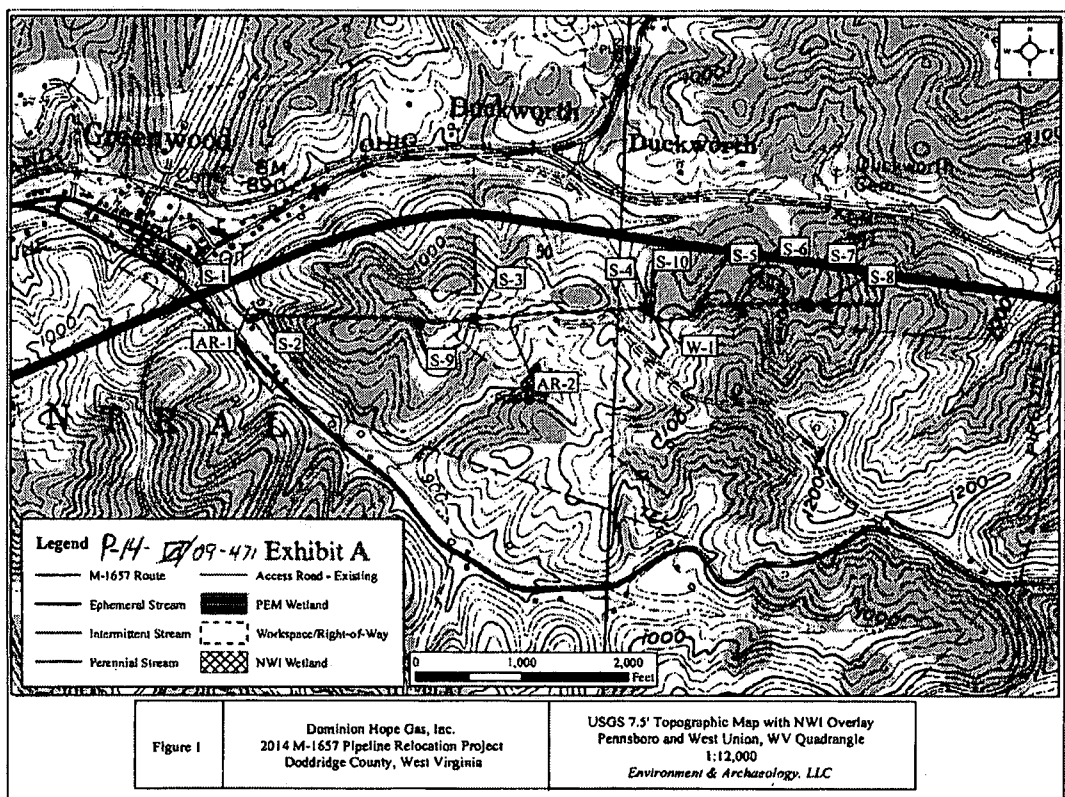



April 17, 2014

The Culture Center
1900 Kanawha Blvd., E.
Charleston, WV 25305-0300

Randall Reid-Smith, Commissioner

Phone 304.558.0220 • www.wvculture.org
Fax 304.558.2779 • TDD 304.558.3562

EEO/AA Employer

Mr. Gregory Eastridge
Dominion Hope Gas
320 Springside Dr.
Suite 320
Akron, Ohio 44333

RE: 2014 M-1657 Pipeline Replacement Project
FR# 14-544-DO

Dear Mr. Eastridge:

We have reviewed the above mentioned project to determine its effects to cultural resources. As required by Section 106 of the National Historic Preservation Act of 1966, as amended, and its implementing regulations, 36 CFR 800: "Protection of Historic Properties," we submit our comments.

According to the information submitted, Dominion Hope Gas, Inc. proposes to replace approximately 5,770 feet of its existing Line M-1657; approximately 756 feet of this line will be replaced in new right-of-way. The segment of pipeline replacement is located on upland terrain southeast of Greenwood, Doddridge County, WV. Our records indicate that no known archaeological resources are located within the proposed project area. In addition, available information indicates the proposed ROW is located on steep and/or previously disturbed terrain that is unlikely to contain significant archaeological resources. It is also our understanding that no permanent above ground components are proposed for construction. As a result, in our opinion there are no historic properties located within the proposed project area. No further consultation is necessary. However, if intact cultural properties are discovered while replacing the pipeline segment, we ask that you cease all activity in the area of discovery and contact this office immediately.

We appreciate the opportunity to be of service. *If you have questions regarding our comments or the Section 106 Process, please contact Lora A. Lamarre-DeMott, Senior Archaeologist, at (304) 558-0240.*

Sincerely,

A handwritten signature in cursive script that reads "Susan M. Pierce". The signature is written in black ink and is positioned above the typed name and title.

Susan M. Pierce
Deputy State Historic Preservation Officer

SMP/LLD



DEPARTMENT OF THE ARMY
HUNTINGTON DISTRICT, CORPS OF ENGINEERS
602 EIGHTH STREET
HUNTINGTON, WEST VIRGINIA 25701-2070

REPLY TO
ATTENTION OF

APR 28 2014

Regulatory Division
South/Transportation Branch
LRH-2014-305-LKR-Dotson Run

Mr. Scott Miller
Dominion Hope Gas, Inc
48 Columbia Boulevard
Clarksburg, West Virginia 26301

Dear Mr. Miller:

I refer to the Department of the Army (DA) permit application received in this office on March 31, 2014, requesting authorization to discharge temporary fill material into waters of the United States associated with the proposed M-1657 Pipeline Replacement Project. You have also requested a preliminary jurisdictional determination (PJD) for the portions of the site characterized by potential waters of the United States. The project site is located within new and existing rights-of-way near Greenwood in Doddridge County, West Virginia. The project has been assigned the following file number: LRH-2014-305-LKR-Dotson Run. Please reference this number on all future correspondence related to this project.

The United States Army Corps of Engineers (Corps) authority to regulate waters of the United States is based on the definitions and limits of jurisdiction contained in 33 CFR 328 and 33 CFR 329. Section 404 of the Clean Water Act (Section 404) requires a DA permit be obtained prior to discharging dredged or fill material into waters of the United States, including wetlands. Section 10 of the Rivers and Harbors Act of 1899 (Section 10) requires a DA permit be obtained for any work in, on, over or under a navigable water.

Based on a review of the aquatic resources in the permit application, eight streams totaling approximately 516 linear feet (lf) are located within the proposed project site, and are indirect tributaries to the Little Kanawha River, a traditional navigable water (TNW) of the United States. The streams identified above and in the attached Table 1 may be waters of the United States in accordance with the Regulatory Guidance Letter for Jurisdictional Determinations (JDs) issued by the Corps on June 26, 2008 (Regulatory Guidance Letter No. 08-02). As indicated in the guidance, this PJD is non-binding and cannot be appealed (33 C.F.R. 331.2) and only provides a written indication that waters of the United States may be present on-site.

You have declined to exercise the option to obtain an approved JD in this instance and at this time. However, for the purposes of the determination of impacts, compensatory mitigation, and other resource protection measures for activities that require authorization from this office the streams referenced in Table 1, will be evaluated as if they are waters of the United States.



Attached please find two (2) copies of the PJD. If you agree with the findings of this PJD and understand your options regarding the same, please sign and date one copy of the form and return it to this office within 30 days of receipt of this letter. You should submit the signed copy to the following address:

United States Army Corps of Engineers
Huntington District
502 Eighth Street
Huntington, West Virginia 25701
Attn: South/Transportation Branch
LRH-2014-305-LKR-Dotson Run

The proposed project, as described in the submitted DA permit application, has been reviewed in accordance with Section 404 and Section 10. Based on your description of the proposed work, and other information available to us, it has been determined that this project will not involve activities subject to the requirements of Section 10. However, this project will include the discharge of dredged or fill material into waters of the United States subject to the requirements of Section 404.

In the DA permit application received in this office on March 31, 2014, you have requested authorization for the discharge of temporary fill material below the ordinary high water mark of 209 lf of eight streams at the locations specified in Table 1 for the replacements and installation of natural gas pipeline of varying diameter. Approximately 5,770 linear feet (lf) of six-inch steel natural gas pipeline will be replaced with 6,176 lf of eight-inch PVC natural gas pipeline. Approximately 756 lf of natural gas pipeline would be installed within new right-of-way. Pipeline replacements and installation would be completed through open cut methods with the trench approximately 5-feet wide and 5-feet deep. You have indicated that the discharge of fill material into the streams will be temporary, and the streams will be restored to pre-project conditions to the maximum extent practicable. The purpose of the M-1657 Pipeline Replacement Project will be to update the existing M-1657 natural gas pipeline within Doddridge County, West Virginia in order to maintain the pipeline's integrity and compliance with safety standards.

Based on your description of the proposed work, and other information available to us it has been determined the proposed discharges of fill material into waters of the United States in conjunction with the proposed M-1657 Pipeline Replacement Project meets the criteria for Nationwide Permit Number (NWP) No. 12 (attached) under the February 21, 2012 Federal Register, Notice of Reissuance of Nationwide Permits (77 FR 10184) provided you comply with all terms and conditions of the enclosed material. The NWPs expire on March 18, 2017. A copy of this NWP can be found on our website at <http://www.lrh.usace.army.mil/Missions/Regulatory.aspx>.

Please be aware this nationwide permit authorization does not obviate the requirement to obtain other Federal, state or local authorizations required by law. A copy of this NWP and verification letter must be supplied to your project engineer responsible for construction activities. A copy of the verification letter must be kept at the site during construction.

Upon completion of the work associated with the Dominion Hope Gas, Inc M-1657 Pipeline Replacement Project, the attached certification must be signed and returned to this office. If you have any questions concerning the above, please contact Kayla N. Adkins of the South/Transportation Branch at 304-399-5850 or by email at kayla.n.adkins@usace.army.mil.

Sincerely,



Richard A. Hemann
Regulatory Project Manager
South/Transportation Branch

Enclosure(s)

Copy Furnished via email

Mr. Greg Eastridge
Dominion Resources, Inc
320 Springside Drive, Suite 320
Akron, Ohio 44333
Gregory.k.eastridge@dom.com



Dominion Hope Gas, Inc.
48 Columbia Boulevard
Clarksburg, WV 26301



March 24, 2014

RECEIVED

BY OVERNIGHT (OR EXPRESS) MAIL
Tracking #1Z F57 654 13 9805 9322

MAR 26 2014

Deborah Carter
United States Fish and Wildlife Service
694 Beverly Pike
Elkins, West Virginia 26241

WVFO

RE: Dominion Hope Gas, Inc.
2014 M-1657 Pipeline Replacement Project
Threatened and Endangered Species Consultation
Central District, Doddridge County, West Virginia

Dear Ms. Carter:

Please review the following information regarding the Dominion Hope Gas, Inc. (DHG) pipeline replacement project, M-1657. To assist with your review of the project, site maps and photographs are enclosed.

DHG is proposing to replace one approximately 5,770-foot long segment of Line M-1657, a 6-inch diameter steel natural gas pipeline, with 6,176 feet of new, 8-inch diameter, plastic pipeline. Approximately 756 feet of the new pipeline will be installed within new pipeline right-of-way (ROW).

DHG currently maintains a Programmatic Agreement (valid 2013 to 2018) with the

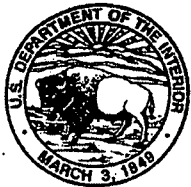

United States Department of the Interior

FISH AND WILDLIFE SERVICE



West Virginia Field Office
694 Beverly Pike
Elkins, West Virginia 26241

In response to your letter above, we have made a "no effect" determination that the project will not affect federally-listed endangered or threatened species. Therefore no biological assessment or further section 7 consultation under the Endangered Species Act is required with the Fish and Wildlife Service. Should project plans change, or if additional information on listed and proposed species becomes available, this determination may be reconsidered.

Definitive determinations of the presence of waters of the United States, including wetlands, in the project area and the need for permits, if any, are made by the U.S. Army Corps of Engineers. They may be contacted at: Huntington District, Regulatory Branch, 502 Eighth Street, Huntington, West Virginia 25701, telephone (304) 399-5710.

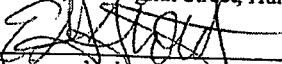
Reviewer's signature and date 4/2/14

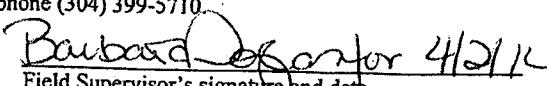
Field Supervisor's signature and date 4/2/14



DIVISION OF NATURAL RESOURCES
Wildlife Resources Section
Operations Center
P.O. Box 67
Elkins, West Virginia 26241-3235
Telephone (304) 637-0245
Fax (304) 637-0250

Earl Ray Tomblin
Governor

Frank Jezloro
Director

March 28, 2014

Mr. Greg Eastridge
Dominion Resources Services, Inc.
320 Springside Drive, Suite 320
Akron, OH 44333

Dear Mr. Eastridge:

We have reviewed our files for information on rare, threatened and endangered (RTE) species and sensitive habitats for the area of the proposed M-1657 Pipeline Replacement project near Greenwood, Doddridge County.

We have no known records of any RTE species or sensitive habitats within the project area. The Wildlife Resources Section knows of no surveys that have been conducted in the area for rare species or rare species habitat. Consequently, this response is based on information currently available and should not be considered a comprehensive survey of the area under review.

The information provided above is the product of a database search and retrieval. This information does not satisfy other consultation or permitting requirements for disturbances to the natural resources of the state, and further consultation may be required. Additionally, any concurrence requirements for federally listed species must come from the US Fish and Wildlife Service.

Thank you for your inquiry, and should you have any questions please feel free to contact me at the above number, extension 2048. Enclosed please find an invoice.

Sincerely,

Barbara Sargent
Environmental Resources Specialist
Wildlife Diversity Unit

enclosure

S:\Monthly\Barb\Invoices\Dominion.doc

Gregory K Eastridge (Services - 6)

From: DEP NPDESEP [DEP.NPDESEP@wv.gov]
Sent: Tuesday, April 22, 2014 10:37 AM
To: DEP NPDESEP; Gregory K Eastridge (Services - 6)
Cc: Hodge, Timothy W; Swiger, Bradley C; Minigh, Christina D
Subject: Approval for WVR310244, 2014 M-1657 Pipeline Replacement Project, Doddridge Co., 2.9 Acres

Scott Miller
Dominion Hope Gas Inc.
48 Columbia Blvd.
Clarksburg, WV 26301

Physical Site Location: CR 50/31, Greenwood

Please be advised that this e-mail constitutes approval for your project associated with Oil and Gas Construction Activities and your registration no. is **WVR310244**. You are now authorized to operate under WV/NPDES General Water Pollution Control Permit No. WV0116815, issued on May 13, 2013.

You should carefully read the contents of this General Permit and become familiar with all requirements needed to remain in compliance with your permit. A "Notice of Termination" form is to be completed and submitted when all disturbed areas are stabilized. You can find the permit and Notice of Termination form via the Internet by visiting Permitting, Division of Water and Waste Management at www.dep.wv.gov. Your annual permit fee has been assessed as \$ 100.00. You will be invoiced by this agency upon the anniversary date of this approval date. Failure to submit the annual fee within ninety (90) days of the due date will render your permit void upon the date you are mailed a certified written notice to that effect. Please be advised that a pro-rated annual permit fee may be assessed upon the completion date and proper stabilization.

If you have any questions relative to this approval, please do not hesitate to contact **Alice Cooper** at (304) 926-0499 Ext. **1103** or by email at alice.e.cooper@wv.gov.

Scott G. Mandirola, Director
WV DEP-Division of Water & Waste Mgt.
601 57th St. SE
Charleston, WV 25304-2345
Phone: (304) 926-0495
Fax: (304) 926-0496



Edwin Wriston <doddridgecountyfpm@gmail.com>

M-1657 Pipeline Project Data

2 messages

Edwin Wriston <doddridgecountyfpm@gmail.com>

Wed, Jul 2, 2014 at 2:57 PM

To: Gregory.K.Eastridge@dom.com

Cc: brett slater <blslater.4774@yahoo.com>

Mr. Eastridge,

In order to fully complete our work on the M-1657 Pipeline Replacement Project for Dominion, designated as DCFPP #14-188, I need to get copies from you of the approval letters for all additional pertinent permits issued by other regulatory bodies such as DEP, USACE, WVDOH, etc. Our ordinance requires we have copies of those approved permits in our files.

Please provide the requested documentation at your earliest convenience.

Respectfully,

--

Edwin L. "Bo" Wriston, Floodplain Manager
Doddridge County Commission
118 East Court Street
West Union, WV 26456
Work Phone: 1-304-873-2631
Mobile Phone: 1-304-629-3735
Fax: 1-304-873-1840
doddridgecountyfpm@gmail.com
www.doddridgecounty.wv.gov

--

CONFIDENTIALITY NOTE: This email message is for the sole use of the intended recipient(s) and may contain confidential, privileged, or sensitive information. Any unauthorized review, use, disclosure, or distribution is strictly prohibited and may be legally accountable.

Gregory K Eastridge (Services - 6) <gregory.k.eastridge@dom.com>

Thu, Jul 10, 2014 at 9:11 AM

To: Edwin Wriston <doddridgecountyfpm@gmail.com>

Cc: "Joshua D Smith (Energy - 5)" <joshua.d.smith@dom.com>, "Daniel J Kukoly (Energy - 5)" <Daniel.J.Kukoly@dom.com>

Good Morning, Mr. Wriston:

Attached and as requested, please find copies of the issued environmental permits secured for the above -reference project. These permits/coordination responses were secured from: USFWS, WVDNR, USACE, SHPO, WVDEP, and WVDNR-Office of Land and Streams.

Thank you for your document inquiry. Please feel free to contact me with any questions.

Sincerely,

Gregory K. Eastridge

Environmental Specialist

Dominion Resources

320 Springside Drive, Suite 320

Akron, Ohio 44333

PH: (330) 664-2576

Cell: (330) 571-7855

Fax: (330) 664-2669

From: Edwin Wriston [mailto:doddridgecountyfpm@gmail.com]

Sent: Wednesday, July 02, 2014 2:57 PM

To: Gregory K Eastridge (Services - 6)

Cc: brett slater

Subject: M-1657 Pipeline Project Data

[Quoted text hidden]

CONFIDENTIALITY NOTICE: This electronic message contains information which may be legally confidential and or privileged and does not in any case represent a firm ENERGY COMMODITY bid or offer relating thereto which binds the sender without an additional express written confirmation to that effect. The information is intended solely for the individual or entity named above and access by anyone else is unauthorized. If you are not the intended recipient, any disclosure, copying, distribution, or use of the contents of this information is prohibited and may be unlawful. If you have received this electronic transmission in error, please reply immediately to the sender that you have received the message in error, and delete it. Thank you.

6 attachments

 **Greenwood DNR RESPONSE.pdf**
221K

 **TA-0386 USFWS RESPONSE.pdf**
558K

 **Greenwood Issued NOI.pdf**
12K

 **Dominion Hope M-1657.pdf**
639K

 **PCN Complete ISSUED.pdf**
3399K

 **Greenwood (M-1657) SHPO Response.pdf**
258K

STATE OF WEST VIRGINIA,
COUNTY OF DODDRIDGE, TO WIT

I, Virginia Nicholson, Editor of THE
HERALD RECORD, a weekly newspaper
published regularly, in Doddridge County,
West Virginia, Do Hereby Certify Upon
Oath That the Accompanying Legal Notice
Entitled:

Floodplain Permit
14-188

was published in said paper for *2*

successive weeks beginning with the issue
of *April 22nd* 2014 and

ending with the issue of
April 29th 2014 and

that said notice contains *189*

WORD SPACE at *115* cents a word

amounts to the sum of \$ *21.74*

FOR FIRST PUBLICATION, SECOND
PUBLICATION IS 75% OF THE FIRST
PUBLICATION

\$ *16.31*

and each publication thereafter

\$ *38.05* TOTAL

EDITOR

Virginia Nicholson

SWORN TO AND SUBSCRIBED

BEFORE ME THIS THE *29th* DAY

OF *April* 2014

NOTARY PUBLIC

Laura J Adams

Legal Advertisement

LEGAL ADVERTISEMENT:
Doddridge County

Floodplain Permit Application

Please take notice that on the 15th day of April, 2014,
DOMINION HOPE GAS INC. #14 -188 filed an
application for a Floodplain Permit to develop land
located at or about: SURFACE OWNERS: ALVADORE
MCCLOY, JR. GREENWOOD, DOTSON RUN,
PARCEL 42 & 43, DEED BOOK 173/634

The Application is on file with the Clerk of the County
Court and may be inspected or copied during regular
business hours. Any interested persons who desire to
comment shall present the same in writing by May 5,
2014.

Delivered to the:

Clerk of the County Court

118 E. Court Street, West Union, WV 26456

Beth A. Rogers, Doddridge County Clerk

Edwin L. "Bo" Wriston, Doddridge County Flood Plain
Manager

4-22-2xb

