

7014 0150 0001 7356 9652

U.S. Postal Service
CERTIFIED MAIL RECEIPT
(Domestic Mail Only; No Insurance Coverage Provided)

For delivery information visit our website at www.usps.com

OFFICIAL USE

Postage	\$.49
Certified Fee	3.45
Return Receipt Fee (Endorsement Required)	2.80
Restricted Delivery Fee (Endorsement Required)	
Total Postage & Fees	\$ 6.74

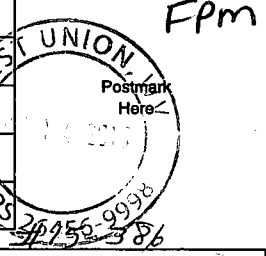

Sent To Mark A. Hotson
 Street, Apt. No., or PO Box No. 791 Buckeye Run Rd
 City, State, ZIP+4 Salem, WV 26426

U.S. Postal Service
CERTIFIED MAIL RECEIPT
(Domestic Mail Only; No Insurance Coverage Provided)

For delivery information visit our website at www.usps.com

OFFICIAL USE

Postage	\$.49
Certified Fee	3.45
Return Receipt Fee (Endorsement Required)	2.80
Restricted Delivery Fee (Endorsement Required)	
Total Postage & Fees	\$ 6.74

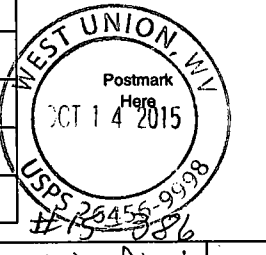

Sent To Belinda S. & Gary W. Mull
 Street, Apt. No., or PO Box No. 176 Hillcrest Rd
 City, State, ZIP+4 Winton, WV 26062

U.S. Postal Service
CERTIFIED MAIL RECEIPT
(Domestic Mail Only; No Insurance Coverage Provided)

For delivery information visit our website at www.usps.com

OFFICIAL USE

Postage	\$.49
Certified Fee	3.45
Return Receipt Fee (Endorsement Required)	2.80
Restricted Delivery Fee (Endorsement Required)	
Total Postage & Fees	\$ 6.74

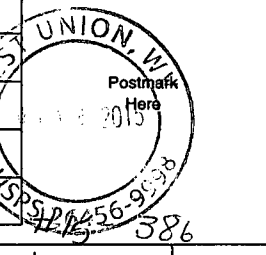

Sent To Eureta Mae Underwood
 Street, Apt. No., or PO Box No. 4234 Watter Fork
 City, State, ZIP+4 West Union, WV 26456

7014 0150 0001 7356 9690

U.S. Postal Service
CERTIFIED MAIL RECEIPT
(Domestic Mail Only; No Insurance Coverage Provided)

For delivery information visit our website at www.usps.com

OFFICIAL USE

Postage	\$.49
Certified Fee	3.45
Return Receipt Fee (Endorsement Required)	2.80
Restricted Delivery Fee (Endorsement Required)	
Total Postage & Fees	\$ 6.74

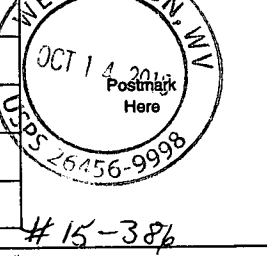

Sent To John Heber McClain
 Street, Apt. No., or PO Box No. HC 67 Box 125
 City, State, ZIP+4 West Union, WV 26456

U.S. Postal Service
CERTIFIED MAIL RECEIPT
(Domestic Mail Only; No Insurance Coverage Provided)

For delivery information visit our website at www.usps.com

OFFICIAL USE

Postage	\$.49
Certified Fee	3.45
Return Receipt Fee (Endorsement Required)	2.80
Restricted Delivery Fee (Endorsement Required)	
Total Postage & Fees	\$ 6.74

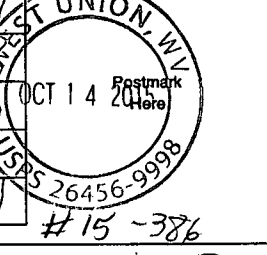

Sent To Secretary of Housing & Urban Dev.
 Street, Apt. No., or PO Box No. 451 17th Street SW
 City, State, ZIP+4 Washington, DC 20410

U.S. Postal Service
CERTIFIED MAIL RECEIPT
(Domestic Mail Only; No Insurance Coverage Provided)

For delivery information visit our website at www.usps.com

OFFICIAL USE

Postage	\$.49
Certified Fee	3.45
Return Receipt Fee (Endorsement Required)	2.80
Restricted Delivery Fee (Endorsement Required)	
Total Postage & Fees	\$ 6.74

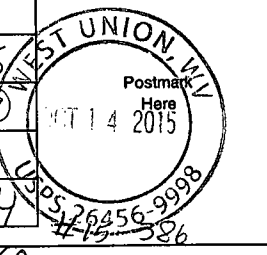

Sent To Curtis T. Coffman
 Street, Apt. No., or PO Box No. 63 Red Lick Rd
 City, State, ZIP+4 New Milton, WV 26411

7014 0150 0001 7356 9713

7014 0150 0001 7356 9683

7014 0150 0001 7356 9706

7014 0150 0001 7356 9720

7014 0150 0001 7356 9799

U.S. Postal Service™
CERTIFIED MAIL™ RECEIPT
(Domestic Mail Only; No Insurance Coverage Provided)

For delivery information visit our website at www.usps.com.

OFFICIAL USE

Postage	\$.49
Certified Fee	3.45
Return Receipt Fee (Endorsement Required)	2.80
Restricted Delivery Fee (Endorsement Required)	
Total Postage & Fees	\$ 6.74

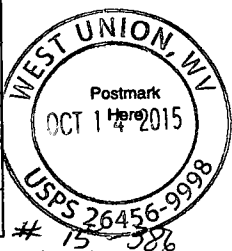

Sent To P.S. Bumbridge ETAL
 Street, Apt. No., or PO Box No. c/o Dale Bumbridge
323 M.outhouse Fork Rd.
 City, State, ZIP+4 New Milton WV 26411

PS Form 3800, August 2006 See Reverse for Instructions

5085 9562 1000 0510 7104

U.S. Postal Service™
CERTIFIED MAIL™ RECEIPT
(Domestic Mail Only; No Insurance Coverage Provided)

For delivery information visit our website at www.usps.com.

OFFICIAL USE

Postage	\$.49
Certified Fee	3.45
Return Receipt Fee (Endorsement Required)	2.80
Restricted Delivery Fee (Endorsement Required)	
Total Postage & Fees	\$ 6.74



Sent To Elizabeth Ann Smith
 Street, Apt. No., or PO Box No. 116 Smilax Lane
 City, State, ZIP+4 Summerville, SC 29483

PS Form 3800, August 2006 See Reverse for Instructions

7014 0150 0001 7356 9812

U.S. Postal Service™
CERTIFIED MAIL™ RECEIPT
(Domestic Mail Only; No Insurance Coverage Provided)

For delivery information visit our website at www.usps.com.

OFFICIAL USE

Postage	\$.49
Certified Fee	3.45
Return Receipt Fee (Endorsement Required)	2.80
Restricted Delivery Fee (Endorsement Required)	
Total Postage & Fees	\$ 6.74

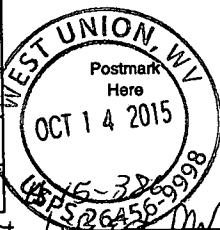

Sent To Roger A & Stacie H. McElhinney
 Street, Apt. No., or PO Box No. c/o Rhonda Ash
743 Piggan Run
 City, State, ZIP+4 West Union WV 26456

PS Form 3800, August 2006 See Reverse for Instructions

6225 9562 1000 0510 7014

U.S. Postal Service™
CERTIFIED MAIL™ RECEIPT
(Domestic Mail Only; No Insurance Coverage Provided)

For delivery information visit our website at www.usps.com.

OFFICIAL USE

Postage	\$.49
Certified Fee	3.45
Return Receipt Fee (Endorsement Required)	2.80
Restricted Delivery Fee (Endorsement Required)	
Total Postage & Fees	\$ 6.74

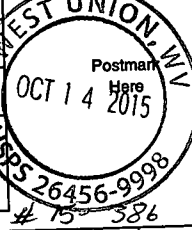

Sent To Roy K & Creola M. Nicholson
 Street, Apt. No., or PO Box No. 422 Sugar Camp Rd
 City, State, ZIP+4 New Milton, WV 26411

PS Form 3800, August 2006 See Reverse for Instructions

7014 0150 0001 7356 9836

U.S. Postal Service™
CERTIFIED MAIL™ RECEIPT
(Domestic Mail Only; No Insurance Coverage Provided)

For delivery information visit our website at www.usps.com.

OFFICIAL USE

Postage	\$.49
Certified Fee	3.45
Return Receipt Fee (Endorsement Required)	2.80
Restricted Delivery Fee (Endorsement Required)	
Total Postage & Fees	\$ 6.74

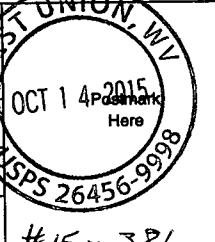

Sent To Nancy McClain O'Dra (Coffman)
 Street, Apt. No., or PO Box No. 123 Red Lick Rd
 City, State, ZIP+4 New Milton WV 26411

PS Form 3800, August 2006 See Reverse for Instructions

5495 9562 1000 0510 7014

U.S. Postal Service™
CERTIFIED MAIL™ RECEIPT
(Domestic Mail Only; No Insurance Coverage Provided)

For delivery information visit our website at www.usps.com.

OFFICIAL USE

Postage	\$.49
Certified Fee	3.45
Return Receipt Fee (Endorsement Required)	2.80
Restricted Delivery Fee (Endorsement Required)	
Total Postage & Fees	\$ 6.74

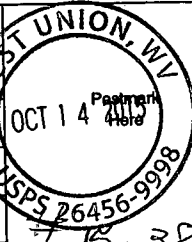

Sent To Charles L. Percy II
 Street, Apt. No., or PO Box No. 516 Kinney St.
 City, State, ZIP+4 Bridgeport, WV 26330

PS Form 3800, August 2006 See Reverse for Instructions

SENDER: COMPLETE THIS SECTION

- Complete items 1, 2, and 3. Also complete item 4 if Restricted Delivery is desired.
- Print your name and address on the reverse so that we can return the card to you.
- Attach this card to the back of the mailpiece, or on the front if space permits.

1. Article Addressed to: # 15-386

Belinda S. & Gary W Mull
 176 Hillcrest Rd
 Weirton, WV 26062

2. Article Number
 (Transfer from service label)

COMPLETE THIS SECTION ON DELIVERY

A. Signature Agent
 Belinda Mull Addressee

B. Received by (Printed Name)
W. Mull

C. Date of Delivery

10-10-15

D. Is delivery address different from item 1? Yes
 If YES, enter delivery address below: No

3. Service Type

- Certified Mail Express Mail
 Registered Return Receipt for Merchandise
 Insured Mail C.O.D.

4. Restricted Delivery? (Extra Fee) Yes

7014 0150 0001 7356 9690

UNITED STATES POSTAL SERVICE

PITTSBURGH PA 15201

16 OCT 15

DN 41



First-Class Mail
Postage & Fees Paid
USPS
Permit No. G-10

• Sender: Please print your name, address, and ZIP+4 in this box •



2015 OCT 19 AM 11:44

BRIDGE COUNTY, WV

George Eidell
Dodge County FloodPlain MGT
18 East Court St., Room 102
West Union, WV 26456

56429790



SENDER: COMPLETE THIS SECTION

- Complete items 1, 2, and 3. Also complete item 4 if Restricted Delivery is desired.
- Print your name and address on the reverse so that we can return the card to you.
- Attach this card to the back of the mailpiece, or on the front if space permits.

1. Article Addressed to: # 15-386

Mark A Hutson
791 Buckeye Run Rd
Salem, WV 26426

2. Article Number
(Transfer from service label)

7014 0150 0001 7356 9652

COMPLETE THIS SECTION ON DELIVERY

A. Signature
 Debora L. Hutson Agent
 Addressee

B. Received by (Printed Name)
Deborah L. Hutson

C. Date of Delivery

D. Is delivery address different from item 1? Yes
 If YES, enter delivery address below: No

3. Service Type
 Certified Mail Express Mail
 Registered Return Receipt for Merchandise
 Insured Mail C.O.D.

4. Restricted Delivery? (Extra Fee) Yes

UNITED STATES POSTAL SERVICE

WV 250

17 OCT '15



First-Class Mail
Postage & Fees Paid
USPS
Permit No. G-10

PM 31

• Sender: Please print your name, address, and ZIP+4 in this box •

FILED

2015 OCT 17 AM 11:44

CLERK
COUNTY

George Eidell

Doddridge County Flood Plain MGT

118 East Court St., Room 102

West Union, WV 26456



SENDER: COMPLETE THIS SECTION

- Complete items 1, 2, and 3. Also complete item 4 if Restricted Delivery is desired.
- Print your name and address on the reverse so that we can return the card to you.
- Attach this card to the back of the mailpiece, or on the front if space permits.

1. Article Addressed to: # 15-386

Curtis T Coffman
63 Red Lick Rd
New Milton, WV 26411

2. Article Number
(Transfer from service label)

7014 0150 0001 7356 9720

COMPLETE THIS SECTION ON DELIVERY

A. Signature

x Nancy Coffman Agent
 Addressee

B. Received by (Printed Name)

NANCY COFFMAN Agent
 Addressee

C. Date of Delivery

10-16-15

D. Is delivery address different from item 1? Yes
If YES, enter delivery address below: No

3. Service Type

- Certified Mail Express Mail
- Registered Return Receipt for Merchandise
- Insured Mail C.O.D.

4. Restricted Delivery? (Extra Fee)

Yes

CHARLESTON
UNITED STATES POSTAL SERVICE

WV 250

16 OCT '15

PM 41



First-Class Mail
Postage & Fees Paid
USPS
Permit No. G-10

• Sender: Please print your name, address, and ZIP+4 in this box •

FILED

2015 OCT 19 AM 11:41

BETHA
COUNTY
DODDGE COUNTY, WV

George Eidell
Dodge County Flood Plain MGT
118 East Court St., Room 102
West Union, WV 26456

00129799

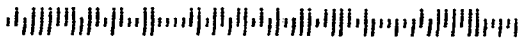

SENDER: COMPLETE THIS SECTION

- Complete items 1, 2, and 3. Also complete item 4 if Restricted Delivery is desired.
- Print your name and address on the reverse so that we can return the card to you.
- Attach this card to the back of the mailpiece, or on the front if space permits.

1. Article Addressed to: # 15-386

Nancy McClain & Ora Coffman
123 Red Lick Rd
New Milton, WV 26411

2. Article Number
(Transfer from service label)

7014 0150 0001 7356 9836

COMPLETE THIS SECTION ON DELIVERY

A. Signature

X *Nancy Coffman* Agent
 Addressee

B. Received by (Printed Name)

NANCY COFFMAN

C. Date of Delivery

10-16-15

D. Is delivery address different from item 1? Yes

If YES, enter delivery address below: No

3. Service Type

- Certified Mail Express Mail
 Registered Return Receipt for Merchandise
 Insured Mail C.O.D.

4. Restricted Delivery? (Extra Fee)

Yes

SENDER: COMPLETE THIS SECTION

- Complete items 1, 2, and 3. Also complete item 4 if Restricted Delivery is desired.
- Print your name and address on the reverse so that we can return the card to you.
- Attach this card to the back of the mailpiece, or on the front if space permits.

1. Article Addressed to: # 15-386

Roy K. & Creola M. Nicholson
 422 Sugar Camp Rd
 New Milton, WV 26411

2. Article Number

(Transfer from service label)

7014 0150 0001 7356 9829

COMPLETE THIS SECTION ON DELIVERY

A. Signature

X  Agent
 Addressee

B. Received by (Printed Name)

Creola M. Nicholson

C. Date of Delivery

10-16-15

D. Is delivery address different from item 1? Yes

If YES, enter delivery address below: No

3. Service Type

- Certified Mail Express Mail
 Registered Return Receipt for Merchandise
 Insured Mail C.O.D.

4. Restricted Delivery? (Extra Fee)

Yes

UNITED STATES

CHARLESTON
POSTAL SERVICE
WV 250



First-Class Mail
Postage & Fees Paid
USPS
Permit No. G-10

16 OCT '15
PM 4 L

- Sender: Please print your name, address, and ZIP+4 in this box •

FILE

2015 OCT 19 AM 11:44

WV
DODD RIDGE COUNTY CLERK
DODD RIDGE COUNTY WV

George Eidell
Doddridge County FloodPlain MGT
118 East Court St., Room 102
West Union, WV 26456

50429790

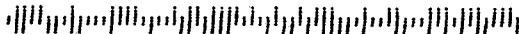

SENDER: COMPLETE THIS SECTION

- Complete items 1, 2, and 3. Also complete item 4 if Restricted Delivery is desired.
- Print your name and address on the reverse so that we can return the card to you.
- Attach this card to the back of the mailpiece, or on the front if space permits.

1. Article Addressed to: #15-386

P.S. Burbridge ET AL
 c/o Dale Burbridge
 323 Meathouse Fork Rd
 New Milton, WV 26411

2. Article Number
 (Transfer from service label)

7014 0150 0001 7356 9799

COMPLETE THIS SECTION ON DELIVERY

A. Signature

Dale Burbridge

- Agent
 Addressee

B. Received by (Printed Name)

DALE BURBRIDGE

C. Date of Delivery

10-16-15

- D. Is delivery address different from item 1? Yes
 If YES, enter delivery address below: No

3. Service Type

- Certified Mail Express Mail
 Registered Return Receipt for Merchandise
 Insured Mail C.O.D.

4. Restricted Delivery? (Extra Fee) Yes

UNITED STATES POSTAL SERVICE

WV 250

16 OCT '15



First-Class Mail®
Postage & Fees Paid
USPS
Permit No. G-10

- Sender: Please print your name, address, and ZIP+4 in this box •

PAID

2015 OCT 19 AM 11:41
METHUEN COUNTY
BRIDGE COUNTY, WV

George Eidell
Bodderidge County Flood Plain MGT
118 East Court St., Room 102
West Union, WV 26456

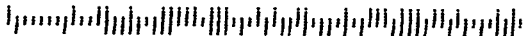

SENDER: COMPLETE THIS SECTION

- Complete items 1, 2, and 3. Also complete item 4 if Restricted Delivery is desired.
- Print your name and address on the reverse so that we can return the card to you.
- Attach this card to the back of the mailpiece, or on the front if space permits.

1. Article Addressed to: # 15-386

Charles L Percy, II
 516 Kinney St
 Bridgeport, WV 26330

2. Article Number
 (Transfer from service label)

7014 0150 0001 7356 9843

COMPLETE THIS SECTION ON DELIVERY

A. Signature

X

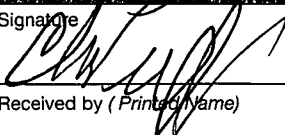

- Agent
 Addressee

B. Received by (Printed Name)

C. Date of Delivery

10-15-15

- D. Is delivery address different from item 1? Yes
 If YES, enter delivery address below: No

3. Service Type

- Certified Mail Express Mail
 Registered Return Receipt for Merchandise
 Insured Mail C.O.D.

4. Restricted Delivery? (Extra Fee) Yes

UNITED STATES POSTAL SERVICE



First-Class Mail
Postage & Fees Paid
USPS
Permit No. G-10

15 OCT '15

• Sender: Please print your name, address, and ZIP+4 in this box •

FILE

2015 OCT 19 AM 11:24

WV
MORGANTHAU
MORGANTHAU COUNTY
MORGANTHAU COUNTY
MORGANTHAU COUNTY

George Eidell
MorgantHAU County FloodPlain MGT
118 East Court St., Room 102
West Union, WV 26456

26456 129799



SENDER: COMPLETE THIS SECTION

- Complete items 1, 2, and 3. Also complete item 4 if Restricted Delivery is desired.
- Print your name and address on the reverse so that we can return the card to you.
- Attach this card to the back of the mailpiece, or on the front if space permits.

1. Article Addressed to: # 15-386

Roger A & Stacy L. II -Life Est. McClain
 c/o Rhonda Ash
 743 Riggin Run
 West Union, WV 26456

COMPLETE THIS SECTION ON DELIVERY

A. Signature

Rhonda Ash Agent
 Addressee

B. Received by (Printed Name)

C. Date of Delivery

10-19-15

D. Is delivery address different from item 1? Yes
 If YES, enter delivery address below: No

Service Type

Certified Mail Express Mail
 Registered Return Receipt for Merchandise
 Insured Mail C.O.D.

Restricted Delivery? (Extra Fee) Yes

7014 0150 0001 7356 9812

UNITED STATES POSTAL SERVICE

POST OFFICE
WV 250
19 OCT 15
DC21

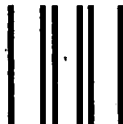

First-Class Mail
Postage & Fees Paid
USPS
Permit No. G-10

• Sender: Please print your name, address, and ZIP+4 in this box •

FILED

2015 OCT 21 AM 10:00

DETH
COUN
DODD BRIDGE COUNTY WV

George Eidell
Doddridge County FloodPlain MGT
118 East Court St., Room 102
West Union, WV 26456



SENDER: COMPLETE THIS SECTION

- Complete items 1, 2, and 3. Also complete item 4 if Restricted Delivery is desired.
- Print your name and address on the reverse so that we can return the card to you.
- Attach this card to the back of the mailpiece, or on the front if space permits.

1. Article Addressed to: #15-386

Eureta Mae Underwood
4234 Nutter Fork
West Union, WV 26456

2. Article Number
(Transfer from service label)

7014 0150 0001 7356 9713

COMPLETE THIS SECTION ON DELIVERY

A. Signature

X *Eureta Mae Underwood* Agent Addressee

B. Received by (Printed Name)

C. Date of Delivery

10-19-15

D. Is delivery address different from item 1? Yes
If YES, enter delivery address below: No

3. Service Type

- Certified Mail Express Mail
 Registered Return Receipt for Merchandise
 Insured Mail C.O.D.

4. Restricted Delivery? (Extra Fee) Yes

UNITED STATES POSTAL SERVICE



First-Class Mail
Postage & Fees Paid
USPS
Permit No. G-10

WV 260
20 OCT '15

• Sender: Please print your name, address, and ZIP+4 in this box •

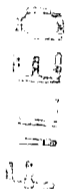

2015 OCT 21 AM 11:00
DODDGE COUNTY
BRIDGE COUNTY, WV

George Eidell
Dodge County Flood Plain MGT
118 East Court St., Room 102
West Union, WV 26456

56129799



CERTIFIED MAIL™

George Eidell
Doddrige Co. FPM
118 E Court St., Room 10:
West Union, WV 26456



7014 0150 0001 7356 9805

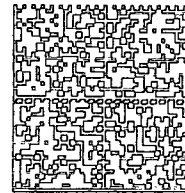

015H14161808
HASLER
\$6.74
10/14/15
Mailed From 26456

US POSTAGE

*hold until
10/19 monday*

Elizabeth Ann Smith
116 Smilax Lane
Summerville,

11-3

NIXIE 296 DE 1999 0011/08/15

RETURN TO SENDER
UNCLAIMED
UNABLE TO FORWARD

BC: 26456126299 *1971-09543-14-43

26456126299

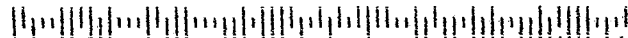

PLACE STICKER AT TOP OF ENVELOPE TO THE RIGHT
OF THE RETURN ADDRESS, FOLD AT DOTTED LINE

SENDER: COMPLETE THIS SECTION

- Complete items 1, 2, and 3. Also complete item 4 if Restricted Delivery is desired.
- Print your name and address on the reverse so that we can return the card to you.
- Attach this card to the back of the mailpiece, or on the front if space permits.

1. Article Addressed to: # 15-386

Elizabeth Ann Smith
116 Smilax Lane
Summerville, SC 29483

2. Article Number
(Transfer from service label)

7014 0150 0001 7356 9805

COMPLETE THIS SECTION ON DELIVERY

A. Signature

X

- Agent
 Addressee

B. Received by (Printed Name)

C. Date of Delivery

D. Is delivery address different from item 1? Yes
If YES, enter delivery address below: No

3. Service Type

- Certified Mail Express Mail
 Registered Return Receipt for Merchandise
 Insured Mail C.O.D.

4. Restricted Delivery? (Extra Fee)

Yes



Doddridge County FPM
118 East Court Street, Suite 102
West Union, WV 26456

Dear Sir or Ma'am,

You are receiving this letter because you have been identified as a land surface and/or mineral rights owner for property or adjacent property related to the proposed development project identified by the following page.

No action is required of you. This letter is simply to inform you of the proposed development.

If you would like to comment on this proposed project, or would like additional information, you may contact the Doddridge County Floodplain Manager at the above address.

Respectfully yours,

George Eide II

Doddridge County Floodplain Manager
304.873.2631
doddridgecountyfpm@gmail.com

By: Catre Slater
Assistant FPM

DIRECTIONS TO THE SITE

Site is directly beside W.V. State Route 25 directly beside the New Milton Post Office. Off US Rte 50 take W.V. Rte 185 to turn onto Rte 25

18. Nature of Activity (Description of project, include all features)

Installing a containment site for 9-210 barrel tanks for oil/water mix and a contained truck pad for loading & unloading tank trucks. Site is partially in a predetermined flood zone, but not in the floodway. Tanks & truck pad will be outside of the flood zone, but roadway leading to and from the tank area will pass through the flood zone.

19. Project Purpose (Describe the reason or purpose of the project, see instructions)

Oil Haulers collects oil/water off various well sites in Doddridge County as well as other counties to store in one centralized location. The oil/water is then picked up by larger tanker trucks to be taken for processing. Work expected to begin in late October thru mid December 2015 weather permitting.

USE BLOCKS 20-23 IF DREDGED AND/OR FILL MATERIAL IS TO BE DISCHARGED

20. Reason(s) for Discharge

Minor earthwork will take place to grade for a looped roadway onto Rte 25 (Meathouse Fork Rd.) In order to level a pad area for the truck pad some fill is necessary, but there will also be minor cut within the property to grade the road. The net result is 205 yd³ of fill within the flood fringes. Over the 2 Ac + site this fill would possibly raise flood waters 3/4" using only the property area under construction.

21. Type(s) of Material Being Discharged and the Amount of Each Type in Cubic Yards:

Type	Amount In Cubic Yards	Type	Amount In Cubic Yards	Type	Amount In Cubic Yards
Site Soils					
	107 yd ³ (cut)		312 yd ³ fill		Net 205 yd ³ fill

22. Surface Area in Acres of Wetlands or Other Waters Filled (see instructions)

Acres **None**
or
Linear Feet

23. Description of Avoidance, Minimization, and Compensation (see instructions)

There should be no adverse affects of the construction to the waters of the U.S. During construction there will be erosion measures taken to prevent soils from being transported offsite & into any body of water which in this case would be Meathouse Fork.

GENERAL MAIL™

George Eidell
Doddridge Co. FPM
118 E Court St., Room 102
West Union, WV 26456



7014 0150 0001 7356 9683

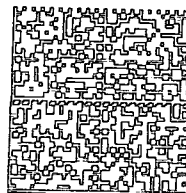

HASLER	015H14161808	US POSTAGE
	\$6.74	
	10/14/15	
Mailed From 26456		

UTK

John Heber McClain
HC 67 Box 125
West Union

NIXIE: 250 FE 1009 0010/21/15

RETURN TO SENDER
NOT DELIVERABLE AS ADDRESSED
UNABLE TO FORWARD

BC: 26456126227 *1971-09549-14-43

26456126227

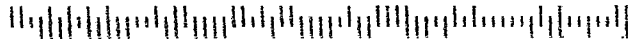

Vertical text on the right edge of the page.

PLACE STICKER AT TOP OF ENVELOPE TO THE RIGHT
OF THE RETURN ADDRESS FOLD AT POSTAL LINE

SENDER: COMPLETE THIS SECTION

- Complete items 1, 2, and 3. Also complete item 4 if Restricted Delivery is desired.
- Print your name and address on the reverse so that we can return the card to you.
- Attach this card to the back of the mailpiece, or on the front if space permits.

1. Article Addressed to: #15-386

John Heber McClain
 HC 67 Box 125
 West Union, WV 26456

COMPLETE THIS SECTION ON DELIVERY

A. Signature Agent
 Addressee
 X

B. Received by (Printed Name) C. Date of Delivery

D. Is delivery address different from item 1? Yes
 If YES, enter delivery address below: No

3. Service Type
 Certified Mail Express Mail
 Registered Return Receipt for Merchandise
 Insured Mail C.O.D.

4. Restricted Delivery? (Extra Fee) Yes

2. Article Number
 (Transfer from service label)

7014 0150 0001 7356 9683

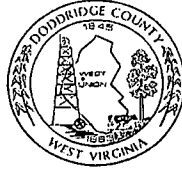

Doddridge County FPM
118 East Court Street, Suite 102
West Union, WV 26456

Dear Sir or Ma'am,

You are receiving this letter because you have been identified as a land surface and/or mineral rights owner for property or adjacent property related to the proposed development project identified by the following page.

No action is required of you. This letter is simply to inform you of the proposed development.

If you would like to comment on this proposed project, or would like additional information, you may contact the Doddridge County Floodplain Manager at the above address.

Respectfully yours,

George Eidell

Doddridge County Floodplain Manager
304.873.2631
doddridgecountyfpm@gmail.com

By: Catie Slater
Assistant FPM

RECTIONS TO THE SITE

Site is directly beside W.V. State Route 25. directly beside the New Milton Post Office. off US Rte 50 take W.V. Rte 185 to turn on to Rte 25

18. Nature of Activity (Description of project, include all features)

Installing a containment site for 9-210 barrel tanks for oil/water mix and a contained truck pad for loading & unloading tank trucks. Site is partially in a predetermined flood zone, but not in the floodway. Tanks & truck pad will be outside of the flood zone, but roadway leading to and from the tank area will pass through the flood zone.

19. Project Purpose (Describe the reason or purpose of the project, see instructions)

Oil Haulers collects oil/water off various well sites in Doddridge County as well as other counties to store in one centralized location. The oil/water is then picked up by larger tanker trucks to be taken for processing. work expected to begin in late October thru mid December 2015 weather permitting.

USE BLOCKS 20-23 IF DREDGED AND/OR FILL MATERIAL IS TO BE DISCHARGED

20. Reason(s) for Discharge

Minor earthwork will take place to grade for a looped roadway onto Rte 25 (Meathouse Fork Rd.) In order to level a pad area for the truck pad some fill is necessary, but there will also be minor cut within the property to grade the road. The net result is 205 yd³ of fill within the flood fringes. Over the 2 Ac + site this fill would possibly raise flood waters 3/4" using only the property area under construction.

21. Type(s) of Material Being Discharged and the Amount of Each Type in Cubic Yards:

Type	Type	Type
Amount in Cubic Yards	Amount in Cubic Yards	Amount in Cubic Yards
Site Soils		
107 yd ³ (cut)	312 yd ³ fill	Net 205 yd ³ fill

22. Surface Area in Acres of Wetlands or Other Waters Filled (see instructions)

Acres **None**
or
Linear Feet

23. Description of Avoidance, Minimization, and Compensation (see instructions)

There should be no adverse affects of the construction to the waters of the U.S. During construction there will be erosion measures taken to prevent soils from being transported offsite & into any body of water which in this case would be Meathouse Fork.

**DODDRIDGE COUNTY
FLOODPLAIN APPLICATION PERMIT FEES**

Accessory Building and/or Appurtenant Structures ----- **\$100.00**
(examples: garage, storage or pole building, carport)
(the total cost of which do not exceed \$10,000.00)

Accessory Building and/or Appurtenant Structures, Additions and/or Substantial Improvement to Single Family Residential or Manufactured Homes, New Single or Multi-Family Residential and Commercial Structures or Substantial Improvement to existing Commercial Structures, Commercial Land Use Changes and Land Altering Activities
(commercial structures includes buildings used for business purposes)
(the total costs of which exceed \$10,000.00 but do not exceed \$50,000.00) ----- **\$250.00**

Accessory Building and/or Appurtenant Structures, Additions and/or Substantial Improvement to Single Family Residential or Manufactured Homes, New Single or Multi-Family Residential and Commercial Structures or Substantial Improvement to existing Commercial Structures, Commercial Land Use Changes and Land Altering Activities
(commercial structures includes buildings used for business purposes)
(the total costs of which exceed \$50,000.00 plus \$2.00 per \$1,000.00 to cover costs over \$50,000.00) ----- **\$350.00**

New Industrial Structures or Additions and/or Substantial Improvement to Existing Industrial Structures, changes in Land Use and Land Altering Activities for Industrial purposes
(industrial structures includes oil and/or natural gas wells, roads, bridges, tank pads, and Buildings used or associated with oil and natural gas purposes)
(the total costs of which do not exceed \$100,000.00) ----- **\$500.00**

A **New Industrial Structures or Additions and/or Substantial Improvement to Existing Industrial Structures, changes in Land Use and Land Altering Activities for Industrial purposes**
(industrial structures includes oil and/or natural gas wells, roads, bridges, tank pads, and Buildings used or associated with oil and natural gas purposes)
(the total costs of which exceed \$100,000.00 plus \$5.00 per \$1,000.00 in costs over \$100,000.00) ----- **\$1,000.00**

Maximum Fee: In no event shall any Floodplain Application Permit Fee charged under the Doddridge County Floodplain Ordinance exceed the sum of \$25,000.00.

*Make check payable to Doddridge County Commission
\$1500.00*

Doddridge County, West Virginia

RECEIPT NO: 5585

DATE: 2015/10/13

FROM: OIL HAULERS LLC

AMOUNT: \$ 1,500.00

ONE THOUSAND FIVE HUNDRED DOLLARS AND 00 CENTS

FOR: #15-386 MEATHOUSE ROAD TANK STORAGE
(BLANDVILLE)

00000002300 FP-BUILDING PERMITS

020-318

TOTAL: \$1,500.00

MICHAEL HEADLEY

SHERIFF & TREASURER

MEC

CLERK

Customer Copy

OIL HAULERS LLC

Doddridge County Commission

2300

Date	Type	Reference	Original Amt.	Balance Due	10/5/2015 Discount	Payment
10/5/2015	Bill	Floodplain Ap	1,500.00	1,500.00		1,500.00
					Check Amount	1,500.00

Checking

Floodplain Application for Salem Remote

1,500.00

Doddridge County Sheriff
Flood Plain Ordinance Fund

1235
69-217/515

DATE October 30, 2015

PAY TO THE ORDER OF OIL HAULERS LLC \$ 1,500.00*****
One Thousand Five Hundred Dollars***** DOLLARS

Security features included. Details on back.



Beth A. Rogers
MP

MEMO #15-386 Refund/Meathouse Rd Rank Storage

⑈001235⑈ ⑆051502175⑆ 1196499⑈

BLUE TRADITIONAL

Mailed on
30/10/15 to
30625 St. Rt. 7
Marietta OH

Oil Haulers LLC
35651 SR 537
Graysville OH 45734

Meathouse # 15-386
Rd
Tank Storage (~~Blount #~~)

This Check
Need Reimbursed

- Rod Kidd -

624-9700

Jerry D'Amato

15-386
Meathouse Rd Tank Storage
~~XXXXXXXXXXXXXXXXXXXX~~
New Milton Post office

DODDRIDGE COUNTY
FLOODPLAIN DEVELOPMENT PERMIT APPLICATION

SECTION 1: GENERAL PROVISIONS (APPLICANT TO READ AND SIGN)

1. No work may start until a permit is issued.
2. The permit may be revoked if any false statements are made herein.
3. If revoked, all work must cease until permit is re-issued.
4. Development shall not be used or occupied until a Certificate of Compliance is issued.
5. The permit will expire if no work is commenced within six months of issuance.
6. Applicant is hereby informed that other permits may be required to fulfill local, state, and federal requirements.
7. Applicant hereby gives consent to the Floodplain Administrator/Manager or his/her representative to make inspections to verify compliance.
8. **I THE APPLICANT CERTIFY THAT ALL STATEMENTS HEREIN AND IN ATTACHMENTS TO THIS APPLICATION ARE, TO THE BEST OF MY KNOWLEDGE, TRUE AND ACCURATE.**

APPLICANT'S SIGNATURE Floyd Griffith

DATE 10-5-15

SECTION 2: PROPOSED DEVELOPMENT (TO BE COMPLETED BY APPLICANT).

IF THE APPLICANT IS NOT A NATURAL PERSON, THE NAME, ADDRESS, AND TELEPHONE NUMBER OF A NATURAL PERSON WHO SHALL BE APPOINTED BY THE APPLICANT TO RECEIVE NOTICE PURSUANT TO ANY PROVISION OF THE CURRENT DODDRIDGE COUNTY FLOODPLAIN ORDINANCE.

APPLICANT'S NAME: OIL HAULERS C/O FLOYD GRIFFITH
ADDRESS: 30625 ST. RT. 7, MARIETTA, OH 45750
TELEPHONE NUMBER: (740) 236-0834

CONTRACTOR NAME: (Unknown at this time)
ADDRESS: _____
TELEPHONE # _____
WV CONTRACTOR LICENCE # _____

ENGINEER'S NAME: ROD KIDD, MSES CONSULTANTS
ADDRESS: 609 WEST MAIN STREET, CLARKSBURG, WV 26302
TELEPHONE NUMBER: (304) 624-9700

PROJECT LOCATION:

NAME OF SURFACE OWNER/OWNERS (IF NOT THE APPLICANT) MARK A. HUTSON

ADDRESS OF SURFACE OWNER/OWNERS (IF NOT THE APPLICANT) _____
791 BUCKEYE RUN ROAD, SALEM, WV 26426

DISTRICT: NEW MILTON

LAND BOOK DESCRIPTION: 2.29 ACRES

DEED BOOK REFERENCE: DB 329/PG 173 (PB 2/55)

TAX MAP REFERENCE: MAP 8, PARCEL 24 & 25

EXISTING BUILDINGS/USES OF PROPERTY: VACANT

NAME OF AT LEAST ONE ADULT RESIDING IN EACH RESIDENCE LOCATED UPON THE SUBJECT PROPERTY N/A

ADDRESS OF AT LEAST ONE ADULT RESIDING IN EACH RESIDENCE LOCATED UPON THE SUBJECT PROPERTY N/A

To avoid delay in processing the application, please provide enough information to easily identify the project location.

DESCRIPTION OF WORK (CHECK ALL APPLICABLE BOXES)

A. STRUCTURAL DEVELOPMENT

<u>ACTIVITY</u>		<u>STRUCTURAL TYPE</u>	
<input checked="" type="checkbox"/>	New Structure	<input type="checkbox"/>	Residential (1 – 4 Family)
<input type="checkbox"/>	Addition	<input type="checkbox"/>	Residential (more than 4 Family)
<input type="checkbox"/>	Alteration	<input checked="" type="checkbox"/>	Non-residential (floodproofing)
<input type="checkbox"/>	Relocation	<input type="checkbox"/>	Combined Use (res. & com.)
<input type="checkbox"/>	Demolition	<input type="checkbox"/>	Replacement
<input type="checkbox"/>	Manufactured/Mobil Home		

B. OTHER DEVELOPMENT ACTIVITIES:

- Fill Mining Drilling Pipelining
- Grading
- Excavation (except for STRUCTURAL DEVELOPMENT checked above)
- Watercourse Alteration (including dredging and channel modification)
- Drainage Improvements (including culvert work)
- Road, Street, or Bridge Construction
- Subdivision (including new expansion)
- Individual Water or Sewer System (*Already in Place*)
- Other (please specify)
-

C. STANDARD SITE PLAN OR SKETCH

- 1. SUBMIT ALL STANDARD SITE PLANS, IF ANY HAVE BEEN PREPARED (ENGINEERING PLANS MUST BE SIGNED AND SEALED).**
- 2. IF STANDARD SITE PLANS HAVE NOT BEEN PREPARED:**
SKETCH ON A SEPARATE 8 ½ X 11 INCH SHEET OF PAPER THE SHAPE AND LOCATION OF THE LOT. SHOW THE LOCATION OF THE INTENDED CONSTRUCTION OR LAND USE INDICATING BUILDING SETBACKS, SIZE & HEIGHT. IDENTIFY EXISTING BUILDINGS, STRUCTURES OR LAND USES ON THE PROPERTY.
- 3. SIGN AND DATE THE SKETCH.**

**ACTUAL TOTAL CONSTRUCTION COSTS OF THE COMPLETE DEVELOPMENT/
PROPOSED CONSTRUCTION PROJECT WITHIN THE FLOODPLAIN**

\$ 200,000.00

D. ADJACENT AND/OR AFFECTED LANDOWNERS:

- 1. NAME AND ADDRESS OF ALL OWNERS OF SURFACE TRACTS ADJACENT TO THE AREA OF THE SURFACE TRACT (UP & DOWN STREAM) UPON WHICH THE PROPOSED ACTIVITY WILL OCCUR AND ALL OTHER SURFACE OWNERS UP & DOWN STREAM) WHO OWN PROPERTY THAT MAY BE AFFECTED BY FLOODING AS IS DEMONSTRATED BY A FLOODPLAIN STUDY OR SURVEY (IF ONE HAS BEEN COMPLETED.**

NAME: _____

NAME: _____

ADDRESS: _____

ADDRESS: _____

SEE ATTACHED SHEET

NAME: _____

NAME: _____

ADDRESS: _____

ADDRESS: _____

- 1. NAME AND ADDRESS OF AT LEAST ONE ADULT RESIDING IN EACH RESIDENCE LOCATED UPON ANY ADJACENT PROPERTY AT THE TIME THE FLOODPLAIN PERMIT APPLICATION IS FILED AND THE NAME AND ADDRESS OF AT LEAST ONE ADULT RESIDING IN ANY HOME ON ANY PROPERTY THAT MAY BE AFFECTED BY FLOODING AS IS DEMONSTRATED BY A FLOODPLAIN STUDY OR SURVEY.**

NAME: _____

NAME: _____

ADDRESS: _____

ADDRESS: _____

SEE ATTACHED SHEET

E. CONFIRMATION FORM

THE APPLICANT ACKNOWLEDGES, AGREES, AND CONFIRMS THAT HE/IT WILL PAY WITHIN 30 DAYS OF RECEIPT OF INVOICE BY THE COUNTY FOR ALL EXPENSES RELATIVE TO THE PERMIT APPLICATION PROCESS GREATER THAN THE REQUIRED DEPOSIT FOR EXPENSES INCLUDING:

- (A) PERSONAL SERVICE OF PROCESS BY THE DODDRIDGE COUNTY SHERIFF AT THE RATES PERMITTED BY LAW FOR SUCH SERVICE.
- (B) SERVICE BY CERTIFIED MAIL RETURN RECEIPT REQUESTED.
- (C) PUBLICATION.
- (D) COURT REPORTING SERVICES AT ANY HEARINGS REQUESTED BY THE APPLICANT.

- (E) CONSULTANTS AND/OR HEARING EXPERTS UTILIZED BY DODDRIDGE COUNTY FLOODPLAIN ADMINISTRATOR/MANAGER OR FLOODPLAIN APPEALS BOARD FOR REVIEW OF MATERIALS AND/OR TESTIMONY REGARDING THE EFFICACY OF GRANTING OR DENYING THE APPLICANT'S FLOODPLAIN PERMIT.

NAME (PRINT): FLOYD GRIFFITH - OIL HAULERS

SIGNATURE: *Floyd Griffith* DATE: 10-5-15

After completing SECTION 2, APPLICANT should submit form and fees to Clerk of Doddridge County Court or his/her representative for review.

SECTION 3: FLOODPLAIN DETERMINATION (to be completed by Floodplain Administrator/Manager or his/her representative)

THE PROPOSED DEVELOPMENT:

THE PROPOSED DEVELOPMENT IS LOCATED ON:

FIRM Panel: _____

Dated: _____

Is **NOT** located in a Specific Flood Hazard Area (Notify applicant that the application review is complete and **NO FLOODPLAIN DEVELOPMENT PERMIT IS REQUIRED**).

Is located in Special Flood Hazard Area.

FIRM zone designation _____

100-Year flood elevation is _____ NGVD .

Stream name _____

Profile # _____

Unavailable

The proposed development is located in a floodway.

See section 4 for additional instructions.

SIGNED _____

DATE _____

**SECTION 4: ADDITIONAL INFORMATION REQUIRED FOR DEVELOPMENT IN
SPECIAL FLOOD HAZARD AREA (To be completed by Floodplain
Administrator/Manager or his/her representative)**

The applicant must submit the documents checked below before the application can be processed.

- A plan showing the location of all existing structures, water bodies, adjacent roads and proposed development.

- Development plans, drawn to scale, and specifications, including where applicable: details for anchoring structures, storage tanks, proposed elevation of lowest floor, (including basement or crawl space), types of water resistant materials used below the first floor, details of flood proofing of utilities located below the first floor and details of enclosures below the first floor. Also _____

- Subdivision or other development plans (If the subdivision or development exceeds 10 lots or 2 acres, whichever is the lesser, the applicant must provide 100-year flood elevations if they are not otherwise available).

- Plans showing the extent of watercourse relocation and/or landform alterations.

- Top of new fill elevation _____ Ft. NGVD.
For floodproofing structures applicant must attach certification from registered engineer or architect.

- Certification from a registered engineer that the proposed activity in a regulatory floodway will not result in any increase in the height of the 100-year flood. A copy of all data and calculations supporting this finding must also be submitted.

- Manufactured homes located in a Flood Hazard Area must have a West Virginia Contractor's License and a Manufactured Home Installation License as required by the Federal Emergency Management Agency (FEMA).

- Other: _____

SECTION 5: PERMIT DETERMINATION (To be completed by Floodplain Administrator/Manager or his/her representative)

I have determined that the proposed activity (type is or is not) in conformance with provisions of the Floodplain Ordinance adopted by the County Commission of Doddridge County on May 21, 2013. The permit is issued subject to the conditions attached to and made part of this permit.

SIGNED _____ DATE _____

If the Floodplain Administrator/Manager found that the above was not in conformance with the provisions of the Doddridge County Floodplain Ordinance and/or denied that application, the applicant may appeal.

APPEALS: Appealed to the County Commission of Doddridge County? Yes No
Hearing Date: _____
County Commission Decision - Approved Yes No

CONDITIONS: _____

SECTION 6: AS-BUILT ELEVATIONS (To be submitted by APPLICANT before Certificate of Compliance is issued).

The following information must be provided for project structures. This section must be completed by a registered professional engineer or a licensed land surveyor (or attach a certification to this application).

COMPLETE 1 OR 2 BELOW:

- 1 Actual (As-Built) Elevation of the top of the lowest floor (including basement or crawl space is _____ FT. NGVD.
- 2 Actual (As Built) elevation of floodproofing is _____ FT. NGVD.

Note: Any work performed prior to submittal of the above information is at risk of the applicant.

SECTION 7: COMPLIANCE ACTION (To be completed by the Floodplain Administrator/Manager or his/her representative).

The Floodplain Administrator/Manager or his/her representative will complete this section as applicable based on inspection of the project to ensure compliance with the Doddridge County Floodplain Ordinance.

INSPECTIONS:

DATE: _____ BY: _____
DEFICIENCIES ? Y/N

COMMENTS _____

SECTION 8: CERTIFICATE OF COMPLIANCE (To be completed by Floodplain Administrator/Manager or his/her representative).

Certificate of Compliance issued: DATE: _____ BY: _____

**CERTIFICATE OF COMPLIANCE
FOR DEVELOPMENT IN SPECIAL FLOOD HAZARD AREA
(OWNER MUST RETAIN)**

PERMIT NUMBER: _____

PERMIT DATE: _____

PURPOSE –

CONSTRUCTION LOCATION: _____

OWNER'S ADDRESS: _____

**THE FOLLOWING MUST BE COMPLETED BY THE FLOODPLAIN
ADMINISTRATOR/MANAGER OR HIS/HER AGENT.**

**COMPLIANCE IS HEREBY CERTIFIED WITH THE REQUIREMENT OF THE
FLOODPLAIN ORDINANCE ADOPTED BY THE COUNTY COMMISSION OF
DODDRIDGE COUNTY ON MAY 21, 2013.**

SIGNED _____ **DATE** _____

Cut/Fill Report

Generated: 2015-10-01 12:32:46
By user: Anthony Friend
Drawing: F:\On-goingProjects\15-400 Oil Haulers - Doddridge
 Co\engineeirng\drafting\F:\On-goingProjects\15-400 Oil Haulers - Doddridge
 Co\engineeirng\drafting\15-400 c100.dwg

Volume Summary							
Name	Type	Cut Factor	Fill Factor	2d Area (Sq. Ft.)	Cut (Cu. Yd.)	Fill (Cu. Yd.)	Net (Cu. Yd.)
CUT FILL	full	1.000	1.500	131470.50	107.22	311.78*	204.56*

Totals				
	2d Area (Sq. Ft.)	Cut (Cu. Yd.)	Fill (Cu. Yd.)	Net (Cu. Yd.)
Total	131470.50	107.22	311.78*	204.56*

* Value adjusted by cut or fill factor other than 1.0

$$204.56 \text{ yd}^3 \times 27 \text{ ft}^3/\text{yd}^3 = 5,523 \text{ ft}^3 \quad (\text{Volume Displacement})$$

Added Depth of water over 2Ac. \Rightarrow

$$\left(\frac{\text{Vol}}{\text{Area}} \right) = \frac{5,523 \text{ ft}^3}{87,120 \text{ ft}^2 (2Ac)} = .06 \text{ ft or } \frac{3}{4}''$$

**U.S. ARMY CORPS OF ENGINEERS
APPLICATION FOR DEPARTMENT OF THE ARMY PERMIT**
33 CFR 325. The proponent agency is CECW-CO-R.

Form Approved -
OMB No. 0710-0003
Expires: 30-SEPTEMBER-2015

Public reporting for this collection of information is estimated to average 11 hours per response, including the time for reviewing instructions, searching existing data sources, gathering and maintaining the data needed, and completing and reviewing the collection of information. Send comments regarding this burden estimate or any other aspect of the collection of information, including suggestions for reducing this burden, to Department of Defense, Washington Headquarters, Executive Services and Communications Directorate, Information Management Division and to the Office of Management and Budget, Paperwork Reduction Project (0710-0003). Respondents should be aware that notwithstanding any other provision of law, no person shall be subject to any penalty for failing to comply with a collection of information if it does not display a currently valid OMB control number. Please DO NOT RETURN your form to either of those addresses. Completed applications must be submitted to the District Engineer having jurisdiction over the location of the proposed activity.

PRIVACY ACT STATEMENT

Authorities: Rivers and Harbors Act, Section 10, 33 USC 403; Clean Water Act, Section 404, 33 USC 1344; Marine Protection, Research, and Sanctuaries Act, Section 103, 33 USC 1413; Regulatory Programs of the Corps of Engineers; Final Rule 33 CFR 320-332. Principal Purpose: Information provided on this form will be used in evaluating the application for a permit. Routine Uses: This information may be shared with the Department of Justice and other federal, state, and local government agencies, and the public and may be made available as part of a public notice as required by Federal law. Submission of requested information is voluntary, however, if information is not provided the permit application cannot be evaluated nor can a permit be issued. One set of original drawings or good reproducible copies which show the location and character of the proposed activity must be attached to this application (see sample drawings and/or instructions) and be submitted to the District Engineer having jurisdiction over the location of the proposed activity. An application that is not completed in full will be returned.

(ITEMS 1 THRU 4 TO BE FILLED BY THE CORPS)

1. APPLICATION NO.	2. FIELD OFFICE CODE	3. DATE RECEIVED	4. DATE APPLICATION COMPLETE
--------------------	----------------------	------------------	------------------------------

(ITEMS BELOW TO BE FILLED BY APPLICANT)

5. APPLICANT'S NAME First - <i>Floyd</i> Middle - Last - <i>Griffith</i> Company - <i>Oil Healers</i> E-mail Address -		8. AUTHORIZED AGENT'S NAME AND TITLE (agent is not required) First - <i>Rodney</i> Middle - <i>Daniel</i> Last - <i>Kidd</i> Company - <i>MSES consultants, inc.</i> E-mail Address - <i>r.kidd@msesinc.com</i>	
6. APPLICANT'S ADDRESS: Address - <i>30625 St Rt 7</i> City - <i>Marietta</i> State - <i>OH</i> Zip <i>45750</i> Country - <i>US</i>		9. AGENT'S ADDRESS: Address - <i>P.O. Drawer 190</i> City - <i>Clarksburg</i> State - <i>WV</i> Zip - <i>26301</i> Country - <i>US</i>	
7. APPLICANT'S PHONE NOS. w/AREA CODE a. Residence b. Business c. Fax <i>(740) 236-0834</i>		10. AGENTS PHONE NOS. w/AREA CODE a. Residence b. Business c. Fax <i>(304) 624-9700</i> <i>(304) 622-0881</i>	

STATEMENT OF AUTHORIZATION

11. I hereby authorize, *MSES consultants inc.* to act in my behalf as my agent in the processing of this application and to furnish, upon request, supplemental information in support of this permit application.

Egd Dufford *10-5-15*
SIGNATURE OF APPLICANT DATE

NAME, LOCATION, AND DESCRIPTION OF PROJECT OR ACTIVITY

12. PROJECT NAME OR TITLE (see instructions) <i>Meathouse Road Tank Storage</i>			
13. NAME OF WATERBODY, IF KNOWN (if applicable) <i>Meathouse Fork</i>		14. PROJECT STREET ADDRESS (if applicable) Address <i>N/A</i>	
15. LOCATION OF PROJECT Latitude: °N <i>39.231100</i> Longitude: °W <i>80.683673</i>		City -	State - Zip -
16. OTHER LOCATION DESCRIPTIONS, IF KNOWN (see instructions) State Tax Parcel ID <i>Map 8, Parcels 24825</i> Municipality Section - Township - <i>New Milton, WV</i> Range - <i>2.29 Ac</i>			

17. DIRECTIONS TO THE SITE

Site is directly beside W.V. State Route 25 directly beside the New Milton Post Office. Off US Rte 50 take W.V. Rte 185 to turn onto Rte 25

18. Nature of Activity (Description of project, include all features)

Installing a containment site for 9-210 barrel tanks for oil/water mix and a contained truck pad for loading & unloading tank trucks. Site is partially in a predetermined flood zone, but not in the floodway. Tanks & truck pad will be outside of the flood zone, but roadway leading to and from the tank area will pass through the flood zone.

19. Project Purpose (Describe the reason or purpose of the project, see instructions)

Oil Haulers collects oil/water of various well sites in Doddridge County as well as other counties to store in one centralized location. The oil/water is then picked up by larger tanker trucks to be taken for processing work expected to begin in late October thru mid December 2015 weather permitting.

USE BLOCKS 20-23 IF DREDGED AND/OR FILL MATERIAL IS TO BE DISCHARGED

20. Reason(s) for Discharge

Minor earthwork will take place to grade for a looped roadway onto Rte 25 (Meathouse Fork Rd.) In order to level a pad area for the truck pad some fill is necessary, but there will also be minor cut within the property to grade the road. The net result is 205 yd³ of fill within the flood fringes. Over the 2 Ac + site this fill would possibly raise flood waters 3/4" using only the property area under construction.

21. Type(s) of Material Being Discharged and the Amount of Each Type in Cubic Yards:

Type Amount in Cubic Yards	Type Amount in Cubic Yards	Type Amount in Cubic Yards
Site Soils		
107 yd ³ (cut)	312 yd ³ fill	Net 205 yd ³ fill

22. Surface Area in Acres of Wetlands or Other Waters Filled (see instructions)

Acres **None**
or
Linear Feet

23. Description of Avoidance, Minimization, and Compensation (see instructions)

There should be no adverse affects of the construction to the waters of the U.S. During construction there will be erosion measures taken to prevent soils from being transported offsite & into any body of water which in this case would be Meathouse Fork.

24. Is Any Portion of the Work Already Complete? Yes No IF YES, DESCRIBE THE COMPLETED WORK

The two acre site was set up around 5-6 years earlier to possibly have a home built there. Both a water well and a septic system exist on site at present and was approved by the Doddridge County Health Dept.

25. Addresses of Adjoining Property Owners, Lessees, Etc., Whose Property Adjoins the Waterbody (if more than can be entered here, please attach a supplemental list).

a. Address-

(see attached)

City - State - Zip -

b. Address-

City - State - Zip -

c. Address-

City - State - Zip -

d. Address-

City - State - Zip -

e. Address-

City - State - Zip -

26. List of Other Certificates or Approvals/Denials received from other Federal, State, or Local Agencies for Work Described in This Application.

AGENCY	TYPE APPROVAL*	IDENTIFICATION NUMBER	DATE APPLIED	DATE APPROVED	DATE DENIED
<i>Doddridge County</i>	<i>Floodplain Development Permit</i>	<i>—</i>	<i>10/6/15</i>		

* Would include but is not restricted to zoning, building, and flood plain permits

27. Application is hereby made for permit or permits to authorize the work described in this application. I certify that this information in this application is complete and accurate. I further certify that I possess the authority to undertake the work described herein or am acting as the duly authorized agent of the applicant.

Fred Difford *10-5-15* *Rodney D. King* *10/6/15*
 SIGNATURE OF APPLICANT DATE SIGNATURE OF AGENT DATE

The Application must be signed by the person who desires to undertake the proposed activity (applicant) or it may be signed by a duly authorized agent if the statement in block 11 has been filled out and signed.

18 U.S.C. Section 1001 provides that: Whoever, in any manner within the jurisdiction of any department or agency of the United States knowingly and willfully falsifies, conceals, or covers up any trick, scheme, or disguises a material fact or makes any false, fictitious or fraudulent statements or representations or makes or uses any false writing or document knowing same to contain any false, fictitious or fraudulent statements or entry, shall be fined not more than \$10,000 or imprisoned not more than five years or both.

CHARLES L. PEARCY, II 1
516 KINNEY STREET
BRIDGEPORT, WV 26330

MAP 8 PARCEL 19
STATUS VACANT

NANCY McCLAIN & ORA COFFMAN 2
123 RED LICK ROAD
NEW MILTON, WV 26411

MAP 8 PARCEL 30
STATUS OCCUPIED

ROY K. & CREOLA M. NICHOLSON 3
422 SUGAR CAMP ROAD
NEW MILTON, WV 26411

MAP 8 PARCEL 26
STATUS OCCUPIED

ROGER A. & STACY L. II -LIFE ESTATE McCLAIN
% RHONDA ASH 4
743 PIGGIN RUN
WEST UNION, WV 26456

MAP 8 PARCEL 23
STATUS OCCUPIED

ELIZABETH ANN SMITH 5
116 SMILAX LANE
SUMMERVILLE, SC 29483

MAP 8 PARCEL 19
STATUS VACANT

P. S. BURBRIDGE ET AL 8
% DALE BURBRIDGE
323 MEATHOUSE FORK ROAD
NEW MILTON, WV 26411

MAP 8 PARCEL 28.1
STATUS VACANT

CURTIS T. COFFMAN 7
63 RED LICK ROAD
NEW MILTON, WV 26411

MAP 8 PARCEL 30.2
STATUS OCCUPIED

ROY K. & CREOLA M. NICHOLSON
422 SUGAR CAMP ROAD
NEW MILTON, WV 26411

MAP 8 PARCEL 27
STATUS VACANT

EURETA MAE UNDERWOOD 6
4234 NUTTER FRK
WEST UNION, WV 26456

MAP 8 PARCEL 28
STATUS OCCUPIED

SECRETARY OF HOUSING & URBAN DEVELOPMENT
451 17th STREET SW
WASHINGTON, DC 20410 9

MAP 8 PARCEL 20
STATUS OCCUPIED

BELINDA S. & GARY W. MULL 10
176 HILLCREST ROAD
WEIRTON, WV 26062

MAP 8 PARCEL 29
STATUS OCCUPIED

JOHN HEBER MCCLAIN 11
HC 67 BOX 125
WEST UNION, WV 26456

MAP 8 PARCEL 30.1
STATUS OCCUPIED

MARK A. HUTSON 12
791 BUCKEYE RUN ROAD
SALEM, WV 26426

MAP 8 PARCEL 24
STATUS VACANT

JOHN HEBER McCLAIN
HC 67 BOX 125
WEST UNION, WV 26456

MAP 8 PARCEL 21
STATUS VACANT

MARK A. HUTSON
791 BUCKEYE RUN ROAD
SALEM, WV 26426

MAP 8 PARCEL 25
STATUS VACANT

END BAD INDUSTRIAL DEVELOPMENT

Like most people in the county I want our families to have good jobs and a healthy thriving community. When the Marcellus gas industry moved in, I thought it would bring good jobs and development. Instead I have experienced almost a Wild West, anything-goes industry. I travel 100 miles a day, six days a week in the southern part of Doddridge County, and I have seen almost criminal activity done to our people. Porto Rico Road is now enduring its third destruction; Route 18 South, Meathouse Fork, Rube Leggett Road, etc.—all destroyed and sometimes left destroyed. Dangerous, inconsiderate traffic, rude out-of-state workers, ill-conceived development everywhere. This is not how I was raised. If you are going to do a job, do it right. At this point, what do we have to lose; let's stand up and say we deserve better than what is going on. We need a set of industrial development standards that will preserve our quality of life.

The latest insult is the proposed development in New Milton. They sneak in with no notification, no review, and are allowed to do this? This New Milton project meets no basic industrial land use design standards and will destroy the lives of at least five families, while disrupting and endangering many more. It is morally, physically and unconditionally wrong. Would the people proposing this facility want to raise their families next door? Ask Bill Trent how fun that is. Have we learned nothing? We need leadership to prevent this kind of development. It's not too late to establish standards that are good for the community and the gas industry.

Questions

- Did Oil Haulers publish their plans, meet with neighbors and the people who would be directly affected, and gain their support, or did they sneak in days before construction and tell a shocked community it was a done deal—you have no say in it?
- Is the project located on a straight section of highway with clear sight lines for safe access and egress, or is it located in the middle of a blind curve?
- Is the project located on a wide two-lane highway with wide berms to allow two trucks to pass safely at the same time, or is it located on a 1-1/2 lane road with almost no berms?
- Is the project located far away from the flood plain to avoid contamination of waterways, or is it located partially in the flood plain, about 75 feet from Meathouse Fork, a tributary of Middle Island Creek which serves as the public drinking water source for West Union and Middlebourne?
- Does the project fit in well with existing adjacent land uses, or is it located in the middle of a residential area?
- Is this project similar to the one that was installed next to Bill Trent's house and created a nightmare for Bill and his family?
- Has the company offered to upgrade the roads to industrial standards to safely handle the truck traffic?
- Can established standards for safe turning radius be met on the site?

- Has a certified engineer determined the effect of this development on flood heights?
- Does the project have a wide setback and buffering plan to protect existing residents from the industrial use?
- Have provisions been made to protect residents from:
 - noxious gas, odors
 - noise
 - dust and dirt
 - glare and heat
 - fire hazards
 - industrial waste
 - traffic
 - aesthetics
 - psychological effects
- Have provisions been made to protect ground water and surface water from potential spills?

Few of these questions have been considered, and none of them addressed. That is the root of our problem.

We should all think about how this proposal would be considered in Bridgeport—would this company dare to even present this to the people there? There is mutual respect between the community and industry there—this is in part why Bridgeport gets the headquarters and we get this kind of garbage proposal. I am not saying that we are Bridgeport. I am talking about mutual respect that is the basis of a good constructive relationship. There are many opportunities for quality development to occur. But we are missing them.

This opposition to the oil water transfer facility is not about stopping the gas industry. The gas industry should develop and provide good jobs and economic development for our county. This opposition is about stopping an unethical, immoral, outrageous development placed in the center of a small community. How can the people of Doddridge County be so disrespected that such a proposal is even considered? It is far below the minimum standards for ethical industrial development established 65 years ago. This proposal tells the people of Doddridge what the gas industry thinks about us. It is time we develop some leadership responsibility and change the parameters of our relationship to one of partners working for the benefit of all. Until we stand up and say we expect the gas industry to meet minimum, basic, well-established industrial development land planning standards, the industry will have no respect for us and we will continually be fighting outrageous proposals and the Wild West behavior the industry demonstrates now. This could be rectified by establishing rules for industrial development and having professional review and planning commission approval required for all gas industry development.

Oil Haulers are looking to purchase land in the New Milton area next to the post office at Meathouse Fork Rd. Their intent is to have 9 tanks placed on the property. The floodplain permit number is #15-386, there have been a couple of calls on this as well as a letter (located in the permit file) from a Miss Creola Nicholson, 422 Sugar Camp Rd. New Milton, 26411 PH# 304-873-2538. Floyd Griffith representative of Oil Haulers (740-236-0834) was contacted, discussed him going out and talking to the community. This would give the people a chance to voice their concerns and for Floyd to address them. I gave him Miss Nicholson's phone number.

10-21-15

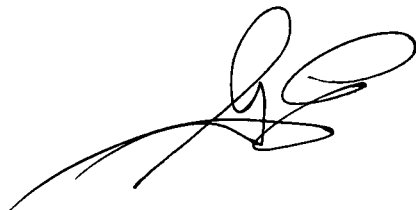
A handwritten signature in black ink, appearing to be 'Danna McKinney', written in a cursive style.

304

873-2813

Danna

McKinney



Creola M. Nicholson
 422 Sugar Camp Rd.
 New Milton, WV 26411-6014

2015 OCT 21 AM 11:09

BETH A. RUGERS
 COUNTY CLERK

CERTIFIED MAIL



7015 0640 0000 2142 0552

Return Receipt Requested

*George Eidell
 Dodd. Co. FPM
 118 E. Court St., Suite 102
 West Union, WV 26456*



FILED

2015 OCT 21 AM 11:09

Creola M. Nicholson

422 Sugar Camp Rd.

New Milton, WV 26411

Oct. 20, 2015

JETHA A. HARRIS
COUNTY CLERK
DODDRIDGE COUNTY, WV

Dear George Eidel,ell,

I am writing in regard to the letter I received from you on Oct. 16, 2015. I own property adjacent to this proposed development.

I have concerns that it is in the floodplain. Our community worked for years to get the Pearcy bridge removed and the road raised 4 feet to help with the flooding in this area. Any possible raise in the flood waters could cause additional flooding. Also, I have seen no permit for this work published, locally.

I am also concerned about spillage from the tanks leaking into the area water wells, because there is always spillage.

My property is leased to the Postal Service. I'm concerned about the congestion of trucks right beside of the post office. This road is not even a 2 lane road, legally. It isn't even wide enough for the DOT to put a yellow line to divide it. I, also, feel all the noise could cause a disturbance for the operation of the post office.

I have concerns about the safety of the community should one of them explode, as did the tank on Rt 23 just below the county line.

The size of the tractor trailers will cause a big hazard to the school buses and area traffic, due to the width of the road. I was almost hit by a tractor trailer just below the New Milton sign. The trucks come around the turn at the bottom of the hill getting a run for it. They Do Not Stop for anything! In the turn, they take up the whole road!

I feel a better location for this development would be on a wider road, not adjacent to houses and out of the floodplain.

Yours truly,

Cecilia M. Nicholson

304-873-2538



REPLY TO
ATTENTION OF

DEPARTMENT OF THE ARMY
HUNTINGTON DISTRICT, CORPS OF ENGINEERS
502 EIGHTH STREET
HUNTINGTON, WEST VIRGINIA 25701-2070

OCT 15 2015

Regulatory Division
South/Transportation Branch
LRH-2015-848-LKR

Mr. Floyd Griffith
Oil Haulers
30625 State Route 7
Marietta, Ohio 45750

Dear Mr. Griffith:

I refer to an application and information received in this office on October 5, 2015, submitted on your behalf by MSES Consultants, Inc. You are requesting Department of the Army (DA) authorization for the construction of a tank storage facility. The project would be located near New Milton, in Doddridge County, West Virginia at latitude 39.23161° and longitude - 80.68335°. This project has been assigned file number LRH-2015-848-LKR. Please refer to this number in any communication regarding this matter.

Section 404 of the Clean Water Act requires that a DA permit be obtained prior to any discharge of dredged or fill material in waters of the United States (U.S.), including wetlands. Section 10 of the Rivers and Harbors Act of 1899 requires that a DA permit be obtained prior to any work in, over or under navigable waters of the U.S. The Corps of Engineers' (Corps) authority to regulate waters and navigable waters of the U.S. is based on the definitions and limits of jurisdiction contained in 33 CFR Parts 328 and 329.

According to the information provided, you propose to construct a storage tank facility for an oil/water mix produced by well sites. The facility would consist of nine storage tanks, an access road and containment berm. The facility would be constructed on dry land east of County Route 25, immediately south of the New Milton Post Office.

Based on a review of the information provided, there would be no discharge of dredged or fill material into waters of the U.S. As a result, Corps authorization would not be required for construction of the proposed facility. In the event it becomes necessary to discharge fill material into waters of the U.S., including wetlands, authorization from the Corps of Engineers would be required.

This letter does not obviate the need to obtain other federal, state or local authorizations required by law. It should be noted it appears the facility may be located within a FEMA-designate floodplain. I recommend you contact the local floodplain manager to determine their requirements regarding this project. If you have any questions regarding this matter please contact Richard Hemann of the South/Transportation Branch at (304) 399-5710.

Sincerely,

A handwritten signature in cursive script that reads "Richard A. Hemann".

Richard A. Hemann
Regulatory Project Manager
South/Transportation Branch

Copy Furnished:

Mr. Rodney D. Kidd
MSES Consultants, Inc.
P.O. Drawer 190
Clarksburg, West Virginia 26301

Floyd Griffith

floyd.griffith@
oilhaulersllc.com

Doddridge County Floodplain Permit Application (New)

Permits applications received October 6, 2015 through October 13, 2015

Announced October 20 , 2015

Permit Application # 15-386

Oil Haulers

Meathouse Road Tank Storage

Location: Blandville – 18 South

Received: 10/06/2015

Announced: 10/20/15

Publication Date: Week of 10/15/15

20-Day Comment Period Window (from Commission Meeting) 11/09/2015

90-Day Approval Window (from date of receipt) N/A

Project Description: Tank Storage yard



The Doddridge Independent
PUBLISHER'S CERTIFICATE

I, Michael D. Zorn, Publisher of The Doddridge Independent, A newspaper of general circulation published in the town of West Union, Doddridge County, West Virginia, do hereby certify that:

Doddridge County
Floodplain Permit Application # 15-386
Please take notice that on the 10th day of October, 2015
Oil Haulers
filed an application for a Floodplain Permit to develop land located at or about:
Meathouse Road Tank Storage
Location: New Milton - 18 South Received: 10/06/2015
Announced: 10/20/15

was published in The Doddridge Independent 2 times commencing on Friday, October 30, 2015 and Ending on Friday, November 6, 2015 at the request of:

George Eidel, Doddridge County Floodplain Manager & Doddridge County Commission

Given under my hand this Friday, November 6, 2015

The publisher's fee for said publication is:
\$ 25.27 1st Run/\$ 18.95 Subsequent Runs
This Legal Ad Total: \$ 44.22



Michael D. Zorn
Publisher of The Doddridge Independent

Subscribed to and sworn to before me on
this date: 11/9/15

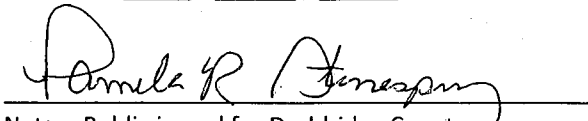

Notary Public in and for Doddridge County
My Commission expires on
The 17th day of MAY 2019

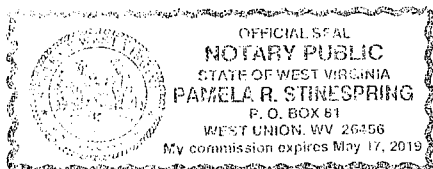

Public Notice • Legal Notice
Doddridge County
Floodplain Permit Application # 15-386
Please take notice that on the 10th day of October, 2015
Oil Haulers
filed an application for a Floodplain Permit to develop land located at or about:
Meathouse Road Tank Storage
Location: New Milton - 18 South
Received: 10/06/2015
Announced: 10/20/15
Publication Date: Week of 10/15/15
20-Day Comment Period Window (from Commission Meeting) 11/09/2015
90-Day Approval Window (from date of receipt) N/A
Project Description: Tank Storage yard
The Application is on file with the Clerk of the County Court and may be inspected or copied during regular business hours. As this project is outside the FEMA identified floodplain of Doddridge County, Doddridge County Floodplain Management has no regulatory authority. Any interested persons who desire to comment shall present the same in writing by August 28, 2015 delivered to Clerk of the County Court
118 E. Court Street, West Union, WV 26456
Beth A Rogers, Doddridge County Clerk
George Eidel, Doddridge County Floodplain Manager
10/30-11/06

The Doddridge Independent

The Doddridge Independent PUBLISHER'S CERTIFICATE

I, Michael D. Zorn, Publisher of The Doddridge Independent, A newspaper of general circulation published in the town of West Union, Doddridge County, West Virginia, do hereby certify that:

Floodplain Permit Application # 15-386

Please take notice that on the 10th day of October, 2015

Oil Haulers

filed an application for a Floodplain Permit to develop land located at or about:

**Meathouse Road Tank Storage
Location: Blandville - 18 South**

was published in The Doddridge Independent 2 times commencing on Friday, October 16, 2015 and Ending on Friday, October 23, 2015 at the request of:

George Eidel, Doddridge County Floodplain Manager & Doddridge County Commission

Given under my hand this Friday, October 23, 2015

The publisher's fee for said publication is:

**\$ 25.27 1st Run/\$ 18.95 Subsequent Runs
This Legal Ad Total: \$ 44.22**

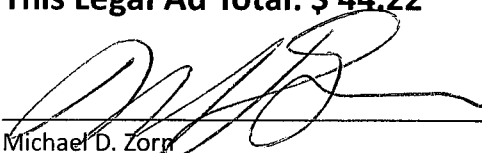

Michael D. Zorn
Publisher of The Doddridge Independent

Subscribed to and sworn to before me on

this date: 10 / 23 / 15

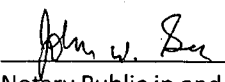

Notary Public in and for Doddridge County

My Commission expires on

The 23 day of Aug 2022

Public Notice • Legal Notice

Doddridge County
Floodplain Permit Application # 15-386
Please take notice that on the 10th day of October, 2015

Oil Haulers
filed an application for a Floodplain Permit to develop land located at or about:
**Meathouse Road Tank Storage
Location: Blandville - 18 South**
Received: 10/06/2015
Announced: 10/20/15
Publication Date: Week of 10/15/15
20-Day Comment Period Window (from Commission Meeting) 11/09/2015
90-Day Approval Window (from date of receipt) N/A
Project Description: Tank Storage yard

The Application is on file with the Clerk of the County Court and may be inspected or copied during regular business hours. As this project is outside the FEMA identified floodplain of Doddridge County, Doddridge County Floodplain Management has no regulatory authority. Any interested persons who desire to comment shall present the same in writing by August 28, 2015, delivered to:
Clerk of the County Court
118 E. Court Street, West Union, WV 26456
Beth A Rogers, Doddridge County Clerk
George Eidel, Doddridge County Flood Plain Manager

10/16 - 10/23

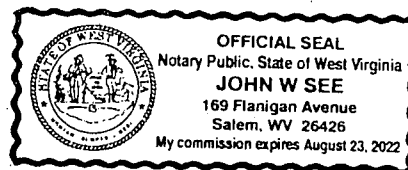

DEMOLITION NOTES:

1. Extreme care is to be taken around existing water well, septic tank, septic clean-outs, and bleed field.

UTILITY NOTES:

1. Contact Miss Utility of WV (811) 72 hours prior to beginning work.
2. Contact all utility providers a minimum of 72 hours prior to expected tie-ins to coordinate preparations and inspection by utility providers.
3. Coordinate with other utilities to assure that other services are not disrupted.

APPROXIMATE QUANTITIES	
Stone for 12' farm road	23 tons
Stone for main haul road	590 tons
Stone for containment dike base	305 tons
Stone for truck pad	82 tons
4000 PSI concrete for truck pad	41 cu. yd.
No. 57 stone for under-drain	35 tons
Geo-textile fabric (Tyvar)	1600 sq. yd.
Tensor TX5 geo-grid	300 sq. yd.
4" PVC perforated pipe for under-drain	180 lin. Ft.
12" Smooth bore HDPE culvert	100 lin. Ft.
Earth work (net fill)	204 cu. yd.

These quantities are for reference only. Contractors are to verify the quantities prior to bidding.

LEGEND

- E — OVERHEAD ELECTRIC
- T — OVERHEAD TELEPHONE
- CATV — OVERHEAD CATV
- E/T — OVERHEAD ELECTRIC / TELEPHONE
- E/TV — OVERHEAD ELECTRIC / CATV
- T/TV — OVERHEAD TELEPHONE / CATV
- E/T/TV — OVERHEAD ELECTRIC / TELEPHONE / CATV
- E --- BURIED ELECTRIC
- T --- BURIED TELEPHONE
- CATV --- BURIED CATV
- E/T --- BURIED ELECTRIC / TELEPHONE
- E/TV --- BURIED ELECTRIC / CATV
- T/TV --- BURIED TELEPHONE / CATV
- E/T/TV --- BURIED ELECTRIC / TELEPHONE / CATV
- W --- POTABLE WATER LINE
- FW --- EXTERIOR FIRE MAIN
- G --- NATURAL GAS
- SS --- SANITARY SEWER
- SD --- STORM SEWER
- SF --- SILT FENCE
- --- PROPOSED CONTOUR LINE
- DI DROP INLET
- UTILITY POLE
- UTILITY POLE WITH TRANSFORMER
- ⊙ GUY POLE
- Y GUY ANCHOR
- ⊗ POLE MOUNTED LIGHT
- T TELEPHONE PEDESTAL
- TV CATV PEDESTAL
- J JUNCTION BOX
- P PULL BOX
- TR PAD MOUNTED TRANSFORMER
- SD STORM SEWER MANHOLE (AS NOTED)
- SS SANITARY SEWER MANHOLE (AS NOTED)
- ⊗ UTILITY VALVE
- RD ROOF DRAIN
- CO UTILITY CLEAN-OUT (AS NOTED)
- PIV POST INDICATOR
- ⊗ FIRE HYDRANT
- W WATER METER
- G NATURAL GAS METER
- GT GREASE TRAP (AS NOTED)
- DIRECTION OF FLOW, DOWN SLOPE (U.N.O.)
- BD BOLLARD
- 948.5 SPOT ELEVATION

- EXISTING BUILDING FOOTPRINT
- PAVEMENT REPLACEMENT
- PAVEMENT REHABILITATION

LEGEND EXISTING

- PROPERTY BOUNDARY
- FLOOD ZONE BOUNDARY
- E-EX — EXISTING OVERHEAD ELECTRIC
- T-EX — EXISTING OVERHEAD TELEPHONE
- CATV-EX — EXISTING OVERHEAD CATV
- E/T-EX — EXISTING OVERHEAD ELECTRIC / TELEPHONE
- E/TV-EX — EXISTING OVERHEAD ELECTRIC / CATV
- T/TV-EX — EXISTING OVERHEAD TELEPHONE / CATV
- E/T/TV-EX — EXISTING OVERHEAD ELECTRIC / TELEPHONE / CATV
- E-EX --- EXISTING BURIED ELECTRIC
- T-EX --- EXISTING BURIED TELEPHONE
- CATV-EX --- EXISTING BURIED CATV
- E/T-EX --- EXISTING BURIED ELECTRIC / TELEPHONE
- E/TV-EX --- EXISTING BURIED ELECTRIC / CATV
- T/TV-EX --- EXISTING BURIED TELEPHONE / CATV
- E/T/TV-EX --- EXISTING BURIED ELECTRIC / TELEPHONE / CATV
- G-EX --- EXISTING NATURAL GAS
- SS-EX --- EXISTING SANITARY SEWER
- SD-EX --- EXISTING STORM DRAIN
- W-EX --- EXISTING WATER
- FW-EX --- EXISTING EXTERIOR FIRE MAIN
- --- EXISTING FENCE
- --- EXISTING CONTOUR LINE
- --- DRAINAGE DITCH
- DI DROP INLET
- UTILITY POLE
- UTILITY POLE WITH TRANSFORMER
- ⊙ GUY ANCHOR
- ⊙ GUY POLE
- ⊗ POLE MOUNTED LIGHT
- T TELEPHONE PEDESTAL
- TV CATV PEDESTAL
- J JUNCTION BOX
- P PULL BOX
- TR PAD MOUNTED TRANSFORMER
- SD STORM SEWER MANHOLE (AS NOTED)
- SS SANITARY SEWER MANHOLE (AS NOTED)
- ⊗ UTILITY VALVE (AS NOTED)
- RD ROOF DRAIN
- CO UTILITY CLEAN-OUT (AS NOTED)
- PIV POST INDICATOR
- ⊗ WATER METER
- G NATURAL GAS METER
- DIRECTION OF FLOW
- 948.5 SPOT ELEVATION
- TR SHRUB TREE & SHRUB LOCATIONS
- B-1 BORE HOLE LOCATION
- TBM TEMPORARY BENCH MARK

UTILITY CONTACTS:
 Telephone Frontier 800-921-8102
 Water & Sewer None
 Electric Mon Power 800-255-3443

PROJECT CONTACTS:
 Owner Oiler Haulers
 Floyd Griffith
 740-236-0834 (cell)
 Engineer MSES consultants, inc.
 Rod Kidd
 304-624-9700 x5365

SURVEY REFERENCE
 Topographic and planimetric information was prepared off of a site survey performed by MSES Consultants, Inc. September 2015.

ELEVATION REFERENCE
 Elevation is based on an elevation of 833.53, being a rebar found by a utility pole in the southwest corner of the property.

UTILITY NOTES
 It shall be the responsibility of the contractor to locate all utilities prior to construction. In the event that a discrepancy in line size or location is found in the field, the contractor shall notify the project manager.

ABBREVIATIONS

- AFB ABOVE FINISHED FLOOR
- ACP ASBESTOS CEMENT PIPE
- CMP CORRUGATED METAL PIPE
- CIP CAST IRON PIPE
- CO CLEAN-OUT
- BD BOLLARD
- B/C CURB BOTTOM
- CI CURB INLET
- T/C CURB TOP
- DI DROP INLET
- DIP DUCTILE IRON PIPE
- EP EDGE OF PAVEMENT
- EXIST & EX EXISTING
- FFE FINISHED FLOOR ELEVATION
- FL FLOW LINE
- B/F FOOTING BOTTOM
- T/F FOOTING TOP
- H/C HANDICAPPED
- HDPE HIGH DENSITY POLYETHYLENE
- INV INVERT
- LF LINEAR FEET
- NIC NOT IN CONTRACT
- T/P PAD TOP
- B/P PAD BOTTOM
- PERF PERFORATED
- PVC POLY VINYL CHLORIDE
- PIV POST INDICATOR VALVE
- RCP REINFORCED CONCRETE PIPE
- RD ROOF DRAIN
- SCH SCHEDULE
- SIM SIMILAR
- TBM TEMPORARY BENCH MARK
- TCP TERRA COTTA PIPE
- T/G TOP OF GRATE
- TYP TYPICAL
- UNO UNLESS NOTED OTHERWISE
- VIF VERIFY IN FIELD
- B/W WALL BOTTOM
- T/W WALL TOP
- V.I.F. VERIFY IN FIELD
- YD YARD DRAIN

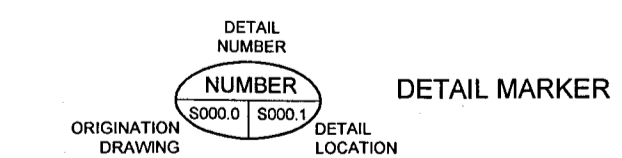

MSES consultants, inc.
 environmental & engineering consultants
 Clarksburg, West Virginia

For **OIL HAULERS**
 Title **MEATHOUSE FORK LEGENDS, NOTES, AND ABBREVIATIONS**

Drawn	AAF	9/15	Scale	AS SHOWN
Engineer	RDK	9/15	Dwg. No.	C100
Checked	RDK	9/15		

Version: 10/2/2015 2:38 PM Created: 9/29/15

REVISIONS			
NO.	DESCRIPTION	DWN.	DATE

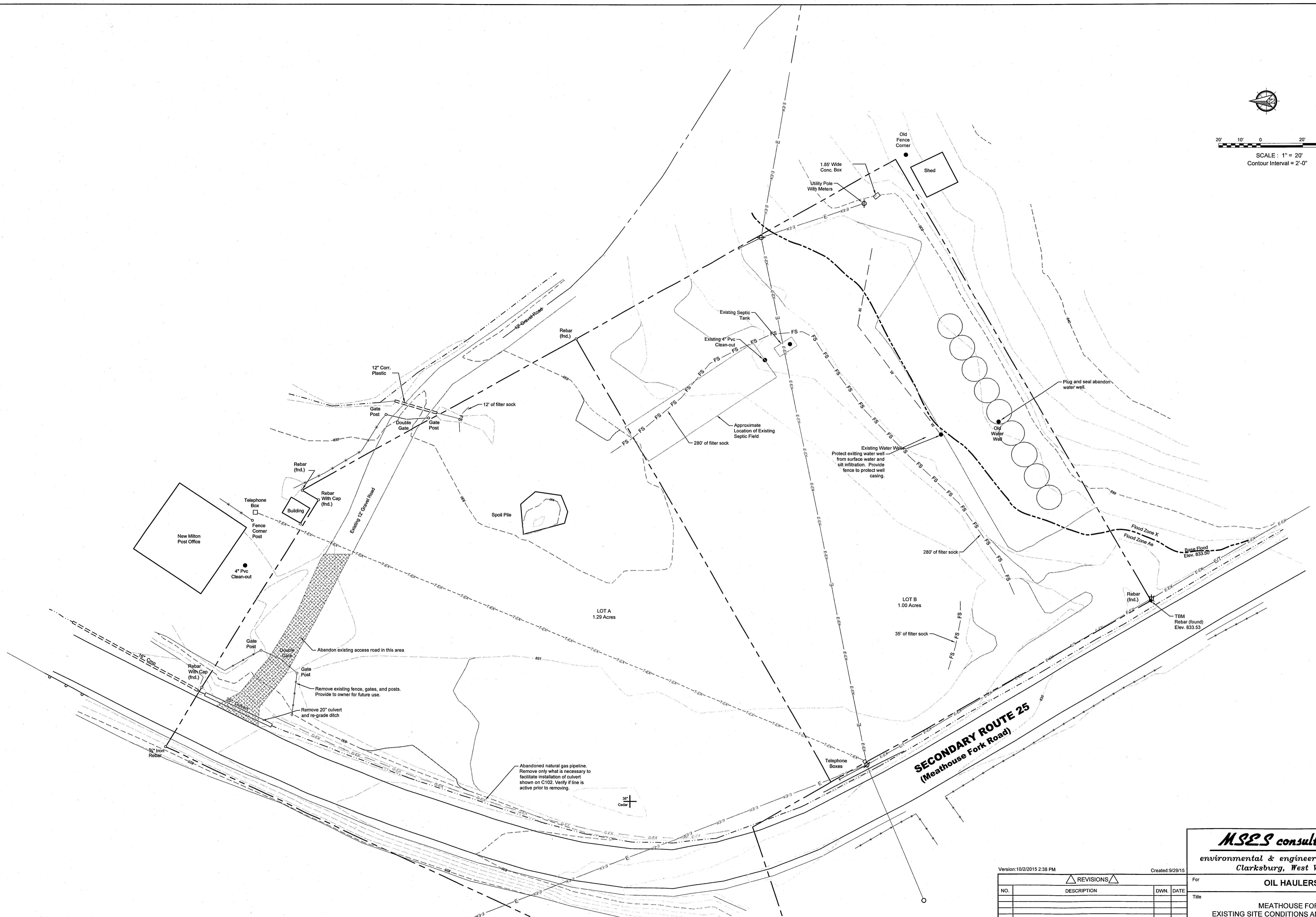
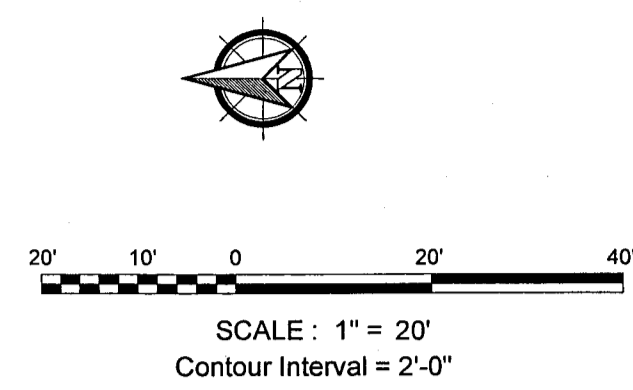

File Path: F:\Drawing\Projects\11-400-01\Hauler - Coalbridge\Coalbridge\dwg\11-400-01-C101.dwg, PLOT: 10/2/2015 2:38:13 PM, Plotter: HP DesignJet 2400, Plot Size: 36x48 inches, Scale: 1/8"=1'-0", Date: 10/2/2015 2:38:13 PM, User: jkelly, Job: 11-400-01, Title: OIL HAULERS EXISTING SITE CONDITIONS AND DEMOLITION, Version: 10/2/2015 2:38:13 PM, Created: 9/29/2015 8:35 AM

Reference:
 Drawings developed from a site survey performed
 by MSES Consultants, Inc. dated September 2015.

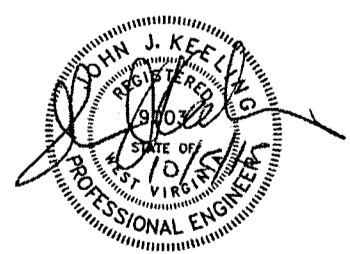

MSES consultants, inc.
 environmental & engineering consultants
 Clarksburg, West Virginia

REVISIONS		
NO.	DESCRIPTION	DWN. DATE

For	OIL HAULERS		
Title	MEATHOUSE FORK EXISTING SITE CONDITIONS AND DEMOLITION		
Drawn	AAF	9/15	Scale AS SHOWN
Engineer	RDK	9/15	Dwg. No. C101
Checked	RDK	9/15	

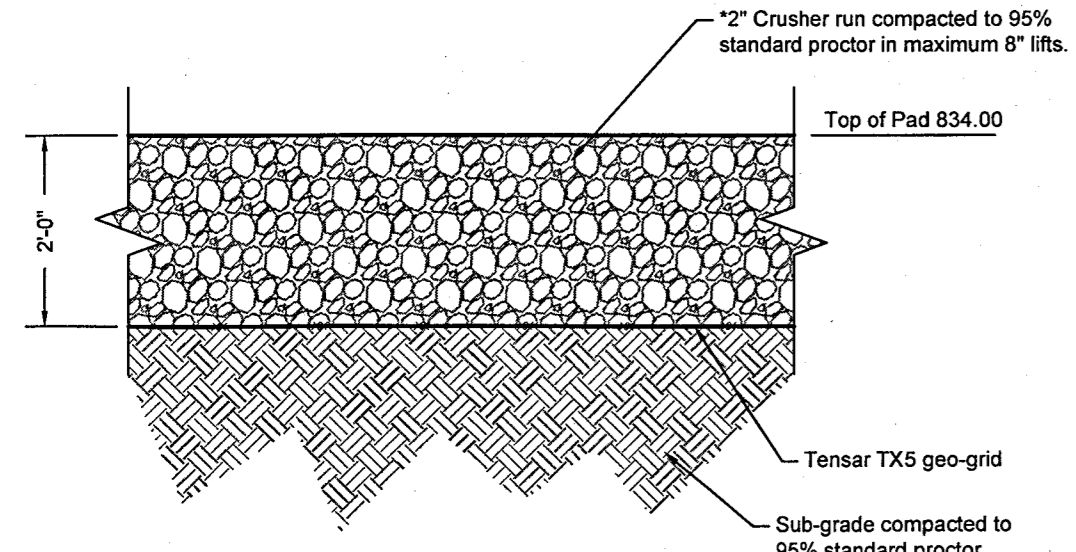

DIKE CONTAINMENT FOUNDATION PAD
NO SCALE

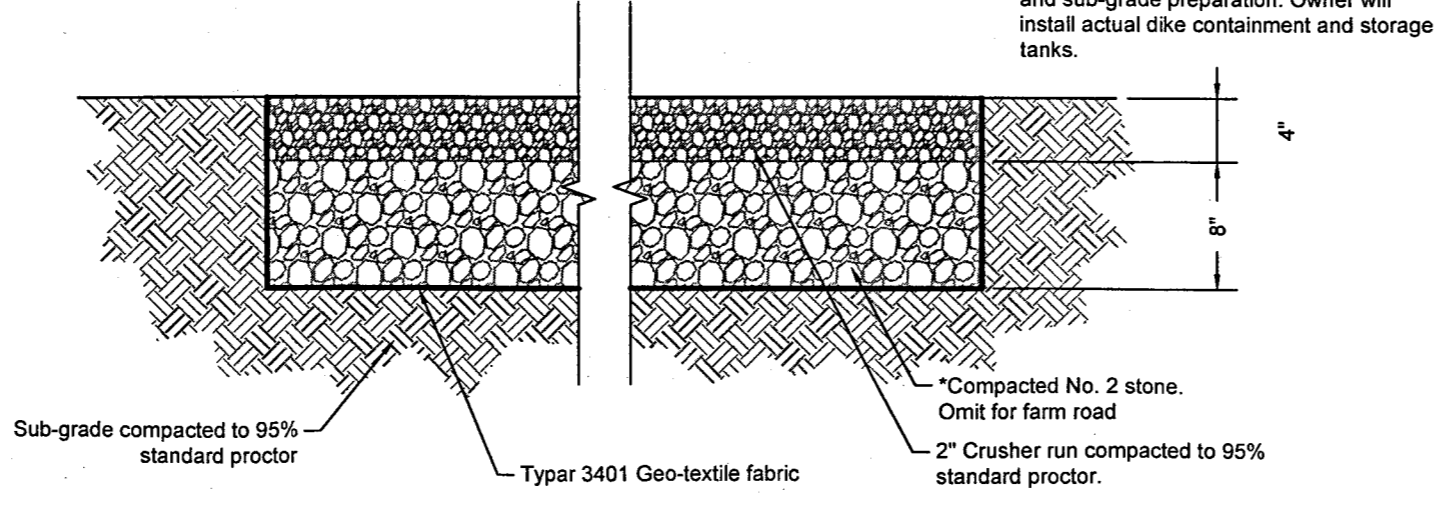

ROADWAY CONSTRUCTION
NO SCALE

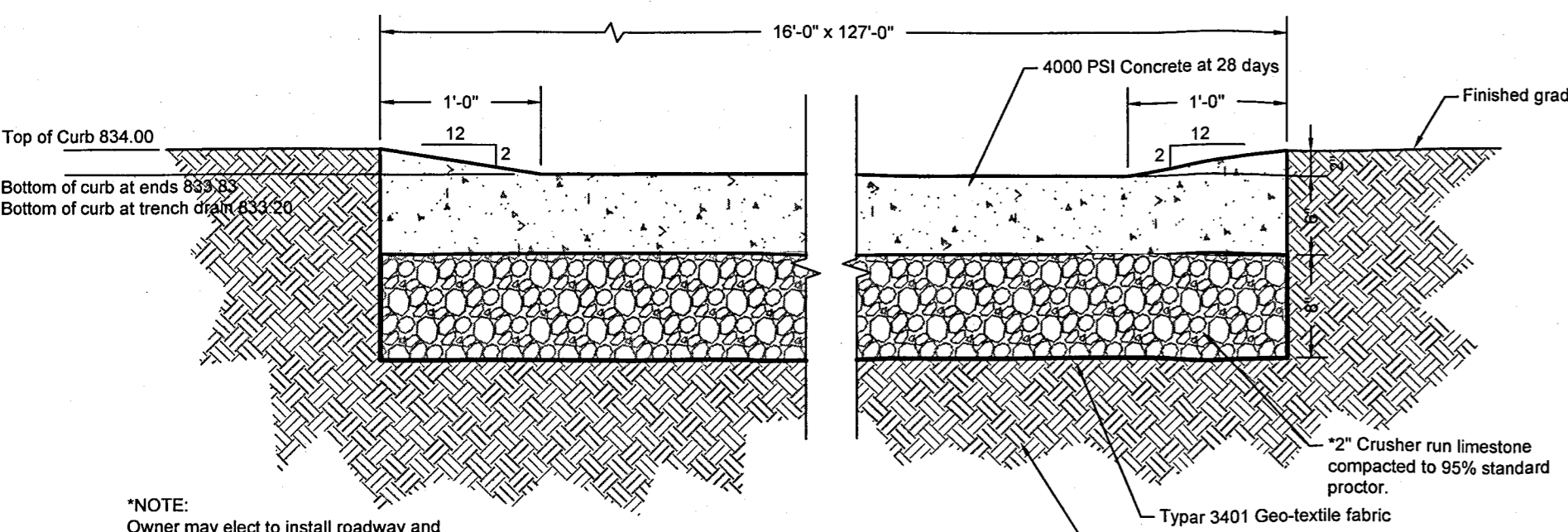

TRUCK PAD
NO SCALE

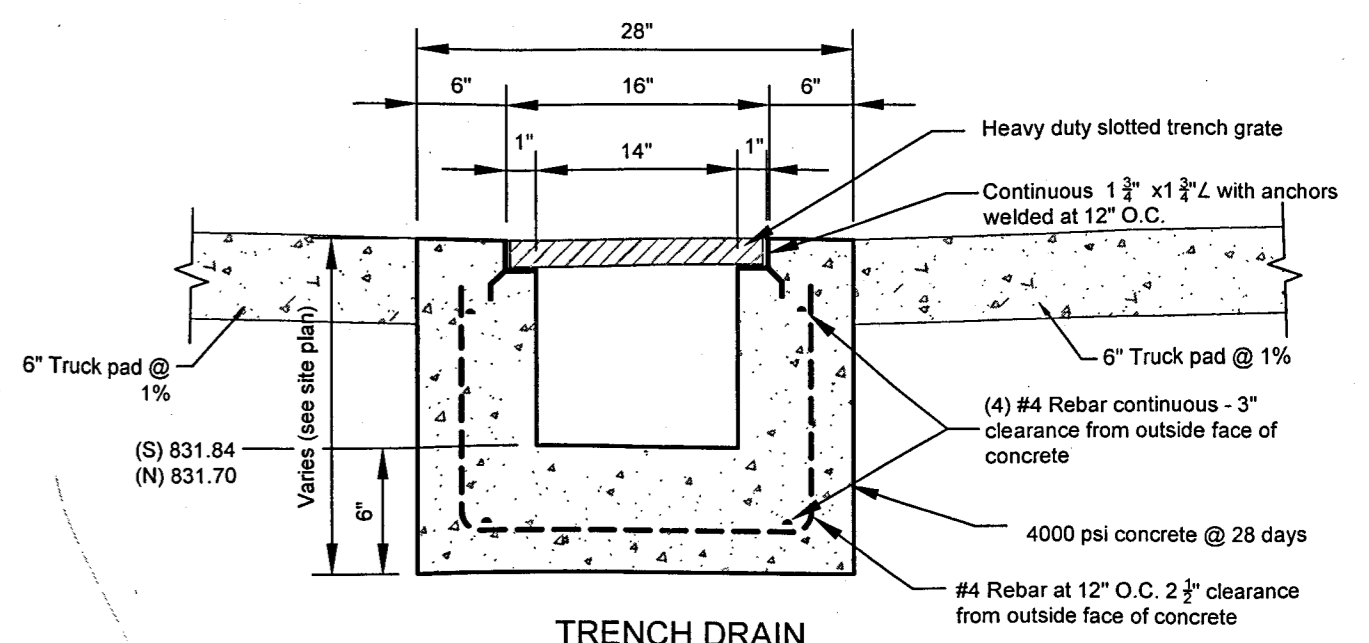

TRENCH DRAIN
NO SCALE

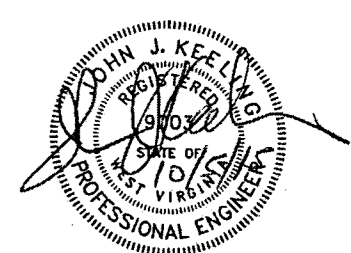
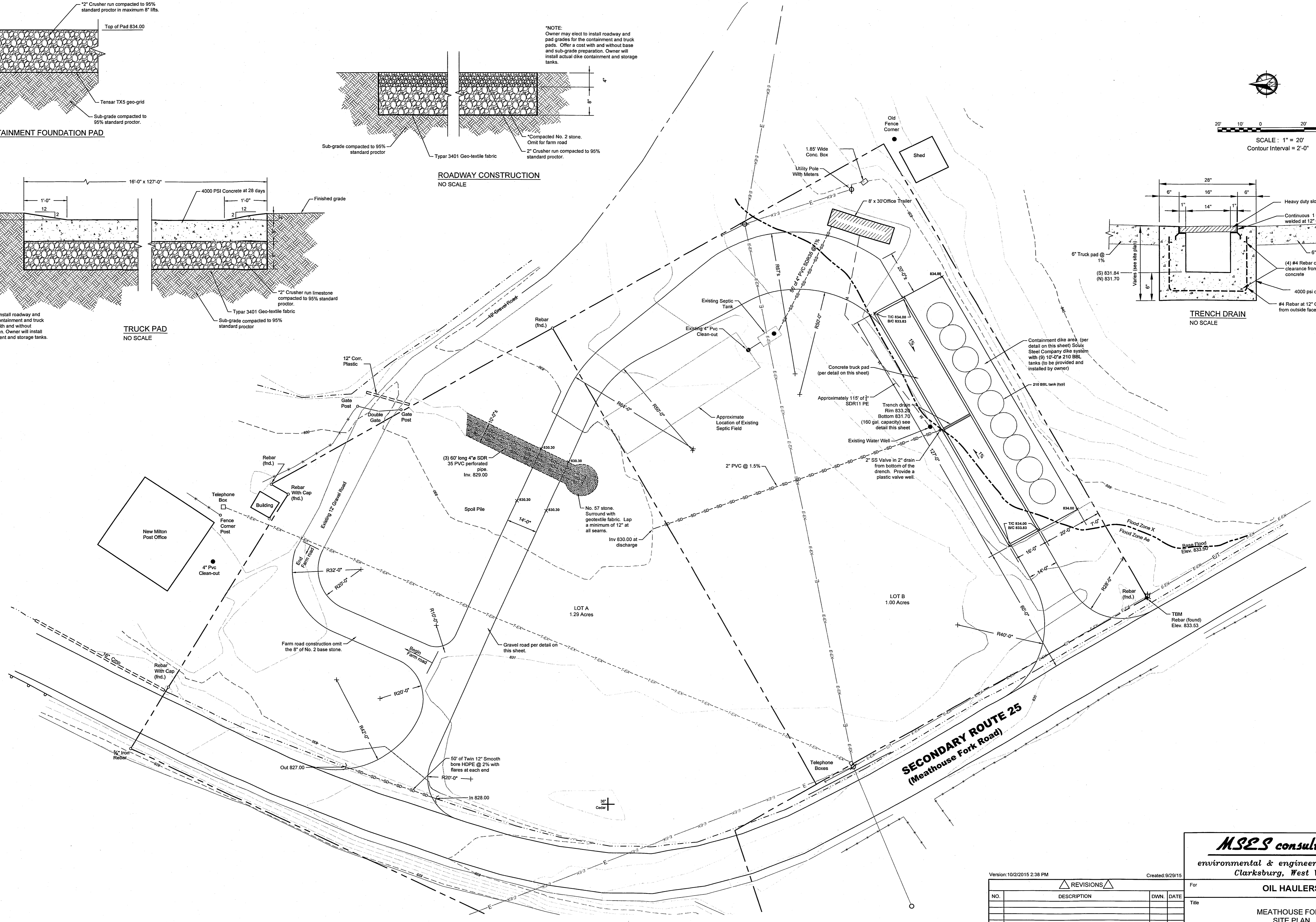
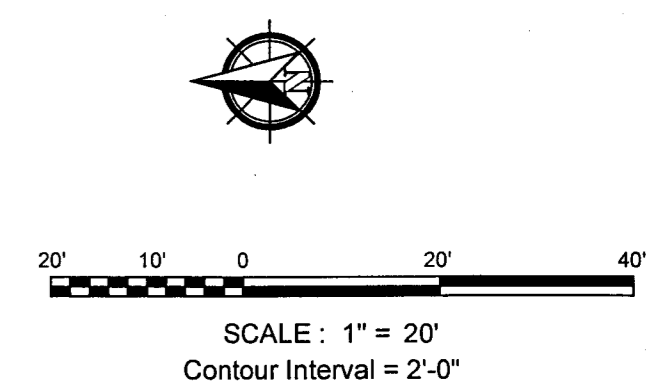

MSES consultants, inc.
environmental & engineering consultants
Clarksburg, West Virginia

For **OIL HAULERS**
Title **MEATHOUSE FORK SITE PLAN**

NO.	REVISIONS	DESCRIPTION	OWN.	DATE

Version: 10/2/2015 2:38 PM	Created: 9/29/15	Scale: AS SHOWN
Drawn: AAF	9/15	Dwg. No. C102
Engineer: RDK	9/15	
Checked: RDK	9/15	

Created: 9/29/2015 8:38 AM
 Last saved: Anthony Friend 10/2/2015 1:21 PM
 Reference: Drawings developed from a site survey performed by MSES Consultants, Inc. dated September 2015.

DEMOLITION NOTES:

1. Extreme care is to be taken around existing water well, septic tank, septic clean-outs, and bleed field.

UTILITY NOTES:

1. Contact Miss Utility of WV (811) 72 hours prior to beginning work.
2. Contact all utility providers a minimum of 72 hours prior to expected tie-ins to coordinate preparations and inspection by utility providers.
3. Coordinate with other utilities to assure that other services are not disrupted.

APPROXIMATE QUANTITIES	
Stone for 12" farm road	23 tons
Stone for main haul road	590 tons
Stone for containment dike base	305 tons
Stone for truck pad	82 tons
4000 PSI concrete for truck pad	41 cu. yd.
No. 57 stone for under-drain	35 tons
Geo-textile fabric (Typar)	1600 sq. yd.
Tensar TX5 geo-grid	300 sq. yd.
4" PVC perforated pipe for under-drain	180 lin. Ft.
12" Smooth bore HDPE culvert	100 lin. Ft.
Earth work (net fill)	204 cu. yd.

These quantities are for reference only. Contractors are to verify the quantities prior to bidding.

LEGEND

- E— OVERHEAD ELECTRIC
- T— OVERHEAD TELEPHONE
- CATV— OVERHEAD CATV
- E/T— OVERHEAD ELECTRIC / TELEPHONE
- E/TV— OVERHEAD ELECTRIC / CATV
- T/TV— OVERHEAD TELEPHONE / CATV
- E/T/TV— OVERHEAD ELECTRIC / TELEPHONE / CATV
- E--- BURIED ELECTRIC
- T--- BURIED TELEPHONE
- CATV--- BURIED CATV
- E/T--- BURIED ELECTRIC / TELEPHONE
- E/TV--- BURIED ELECTRIC / CATV
- T/TV--- BURIED TELEPHONE / CATV
- E/T/TV--- BURIED ELECTRIC / TELEPHONE / CATV
- W--- POTABLE WATER LINE
- FW--- EXTERIOR FIRE MAIN
- G--- NATURAL GAS
- SS--- SANITARY SEWER
- SD--- STORM SEWER
- SF--- FENCE
- SF--- SILT FENCE
- #--- PROPOSED CONTOUR LINE
- DI DROP INLET
- UTILITY POLE
- UTILITY POLE WITH TRANSFORMER
- ⊙ GUY POLE
- Y GUY ANCHOR
- ⊗ POLE MOUNTED LIGHT
- T TELEPHONE PEDESTAL
- TV CATV PEDESTAL
- J JUNCTION BOX
- P PULL BOX
- TT PAD MOUNTED TRANSFORMER
- SD STORM SEWER MANHOLE (AS NOTED)
- SS SANITARY SEWER MANHOLE (AS NOTED)
- ⊗ UTILITY VALVE
- RD ROOF DRAIN
- CO UTILITY CLEAN-OUT (AS NOTED)
- PV POST INDICATOR
- FIRE HYDRANT
- ⊙ WATER METER
- G NATURAL GAS METER
- ST GREASE TRAP (AS NOTED)
- DIRECTION OF FLOW; DOWN SLOPE (U.N.O.)
- BD BOLLARD
- # SPOT ELEVATION

- EXISTING BUILDING FOOTPRINT
- PAVEMENT REPLACEMENT
- PAVEMENT REHABILITATION

LEGEND EXISTING

- PROPERTY BOUNDARY
- FLOOD ZONE BOUNDARY
- E-EX— EXISTING OVERHEAD ELECTRIC
- T-EX— EXISTING OVERHEAD TELEPHONE
- CATV-EX— EXISTING OVERHEAD CATV
- E/T-EX— EXISTING OVERHEAD ELECTRIC / TELEPHONE
- E/TV-EX— EXISTING OVERHEAD ELECTRIC / CATV
- T/TV-EX— EXISTING OVERHEAD TELEPHONE / CATV
- E/T/TV-EX— EXISTING OVERHEAD ELECTRIC / TELEPHONE / CATV
- E-EX--- EXISTING BURIED ELECTRIC
- T-EX--- EXISTING BURIED TELEPHONE
- CATV-EX--- EXISTING BURIED CATV
- E/T-EX--- EXISTING BURIED ELECTRIC / TELEPHONE
- E/TV-EX--- EXISTING BURIED ELECTRIC / CATV
- T/TV-EX--- EXISTING BURIED TELEPHONE / CATV
- E/T/TV-EX--- EXISTING BURIED ELECTRIC / TELEPHONE / CATV
- G-EX--- EXISTING NATURAL GAS
- SS-EX--- EXISTING SANITARY SEWER
- SD-EX--- EXISTING STORM DRAIN
- W-EX--- EXISTING WATER
- FW-EX--- EXISTING EXTERIOR FIRE MAIN
- EXISTING FENCE
- EXISTING CONTOUR LINE
- DRAINAGE DITCH
- DI DROP INLET
- UTILITY POLE
- UTILITY POLE WITH TRANSFORMER
- Y GUY ANCHOR
- ⊙ GUY POLE
- ⊗ POLE MOUNTED LIGHT
- T TELEPHONE PEDESTAL
- TV CATV PEDESTAL
- J JUNCTION BOX
- P PULL BOX
- TT PAD MOUNTED TRANSFORMER
- SD STORM SEWER MANHOLE (AS NOTED)
- SS SANITARY SEWER MANHOLE (AS NOTED)
- ⊗ UTILITY VALVE (AS NOTED)
- RD ROOF DRAIN
- FIRE HYDRANT
- ⊙ WATER METER
- G NATURAL GAS METER
- DIRECTION OF FLOW
- # SPOT ELEVATION
- TRC TREE & SHRUB LOCATIONS
- B-1 BORE HOLE LOCATION
- TBM TEMPORARY BENCH MARK

UTILITY CONTACTS:

Telephone Frontier 800-921-8102
 Water & Sewer None
 Electric Mon Power 800-255-3443

PROJECT CONTACTS:

Owner Oiler Haulers
 Floyd Griffith
 740-236-0834 (cell)
 Engineer MSES consultants, inc.
 Rod Kidd
 304-624-9700 x5365

SURVEY REFERENCE

Topographic and planimetric information was prepared off of a site survey performed by MSES Consultants, Inc. September 2015.

ELEVATION REFERENCE

Elevation is based on an elevation of 833.53, being a rebar found by a utility pole in the southwest corner of the property.

UTILITY NOTES

It shall be the responsibility of the contractor to locate all utilities prior to construction. In the event that a discrepancy in line size or location is found in the field, the contractor shall notify the project manager.

ABBREVIATIONS

- AFF ABOVE FINISHED FLOOR
- ACP ASBESTOS CEMENT PIPE
- CMP CORRUGATED METAL PIPE
- CIP CAST IRON PIPE
- CO CLEAN-OUT
- BD BOLLARD
- B/C CURB BOTTOM
- CI CURB INLET
- CTC CURB TOP
- DI DROP INLET
- DIP DUCTILE IRON PIPE
- EP EDGE OF PAVEMENT
- EXIST & EX EXISTING
- FFE FINISHED FLOOR ELEVATION
- FL FLOW LINE
- FB FOOTING BOTTOM
- TF FOOTING TOP
- HIC HANDICAPPED
- HDPE HIGH DENSITY POLYETHYLENE
- INV INVERT
- LF LINEAR FEET
- NIC NOT IN CONTRACT
- T/P PAD TOP
- B/P PAD BOTTOM
- PERF PERFORATED
- PVC POLY VINYL CHLORIDE
- PV POST INDICATOR VALVE
- RCP REINFORCED CONCRETE PIPE
- RD ROOF DRAIN
- SCH SCHEDULE
- SIM SIMILAR
- TBM TEMPORARY BENCH MARK
- TOP TERRA COTTA PIPE
- T/G TOP OF GRATE
- TYP TYPICAL
- UNO UNLESS NOTED OTHERWISE
- VIF VERIFY IN FIELD
- BW WALL BOTTOM
- TW WALL TOP
- V.I.F. VERIFY IN FIELD
- YD YARD DRAIN

DETAIL NUMBER
 NUMBER
 ORIGINATION DETAIL LOCATION

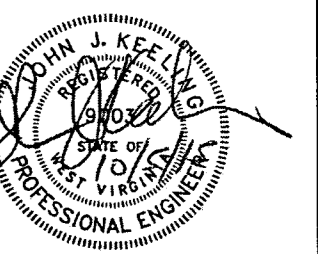

MSES consultants, inc.
 environmental & engineering consultants
 Clarksburg, West Virginia

For **OIL HAULERS**

Title **MEATHOUSE FORK
 LEGENDS, NOTES, AND ABBREVIATIONS**

Drawn AAF 9/15 Scale AS SHOWN
 Engineer RDK 9/15 Dwg. No. C100
 Checked RDK 9/15

REVISIONS			
NO.	DESCRIPTION	DWN.	DATE

Version: 10/2/2015 2:38 PM

Created: 9/29/15

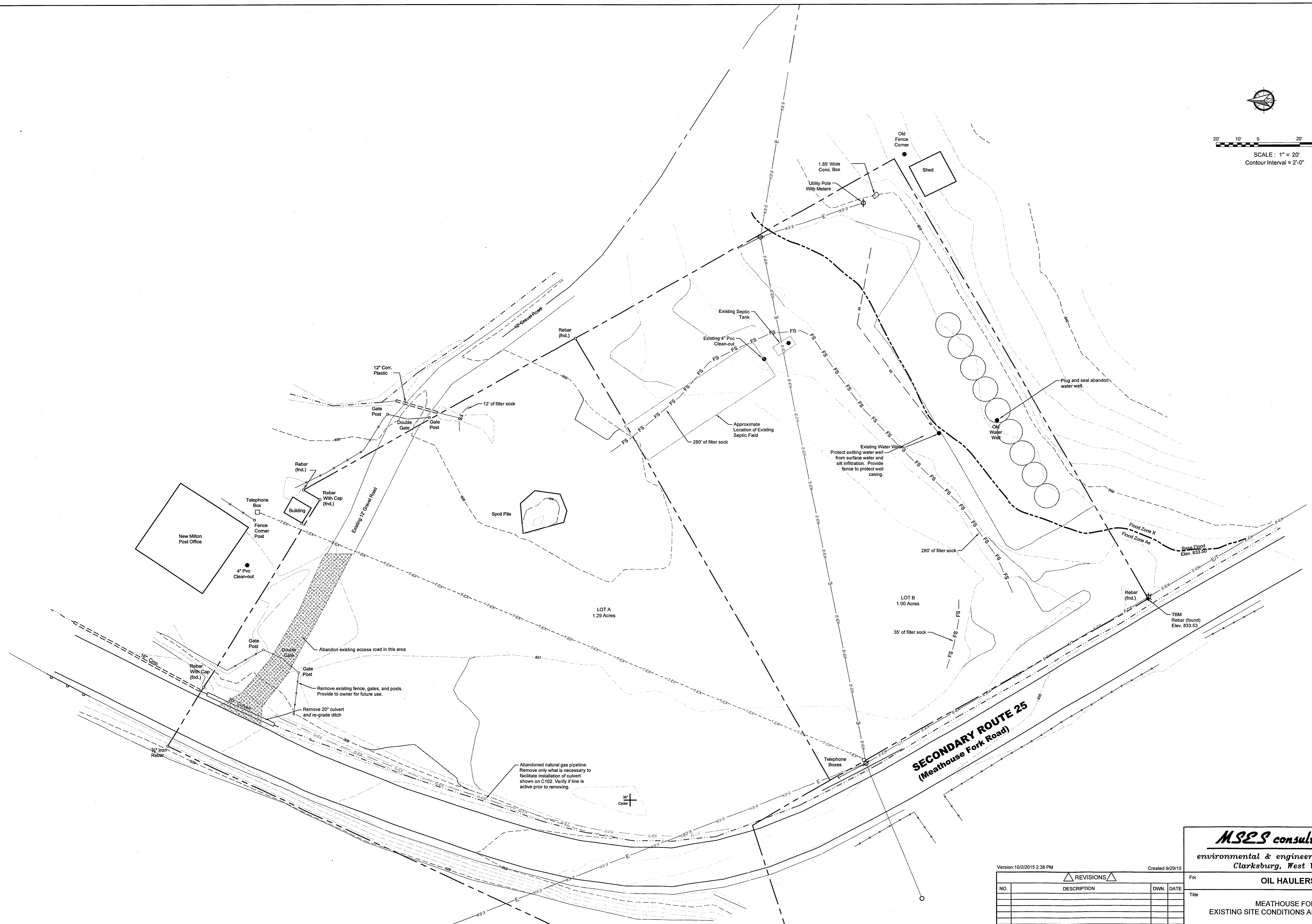
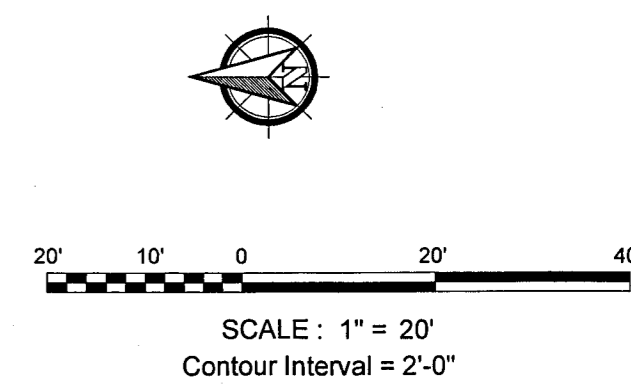

MSES consultants, inc.
 environmental & engineering consultants
 Clarksburg, West Virginia

For **OIL HAULERS**
 Title **MEATHOUSE FORK EXISTING SITE CONDITIONS AND DEMOLITION**
 Drawn AAF 9/15 Scale AS SHOWN
 Engineer RDK 9/15 Dwg. No. C101
 Checked RDK 9/15

Version: 10/2/2015 2:38 PM Created: 9/29/15

REVISIONS			
NO.	DESCRIPTION	DWN.	DATE

L:\m\meathouse\m\1022015\1022015_1.dwg Created: 10/2/2015 2:38 PM
 Reference: Drawings developed from a site survey performed by MSES Consultants, Inc. dated September 2015.

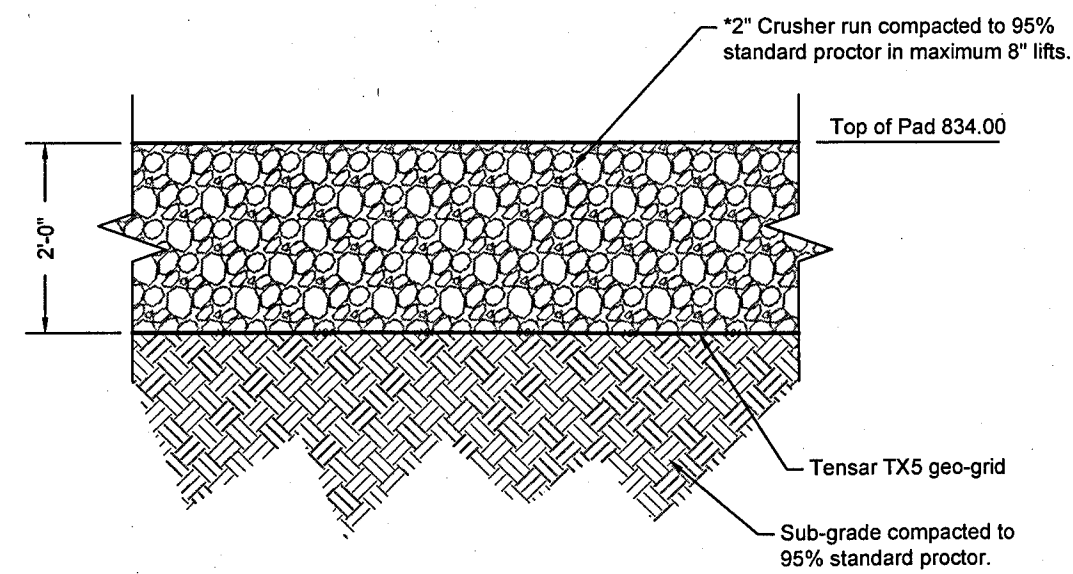

DIKE CONTAINMENT FOUNDATION PAD
NO SCALE

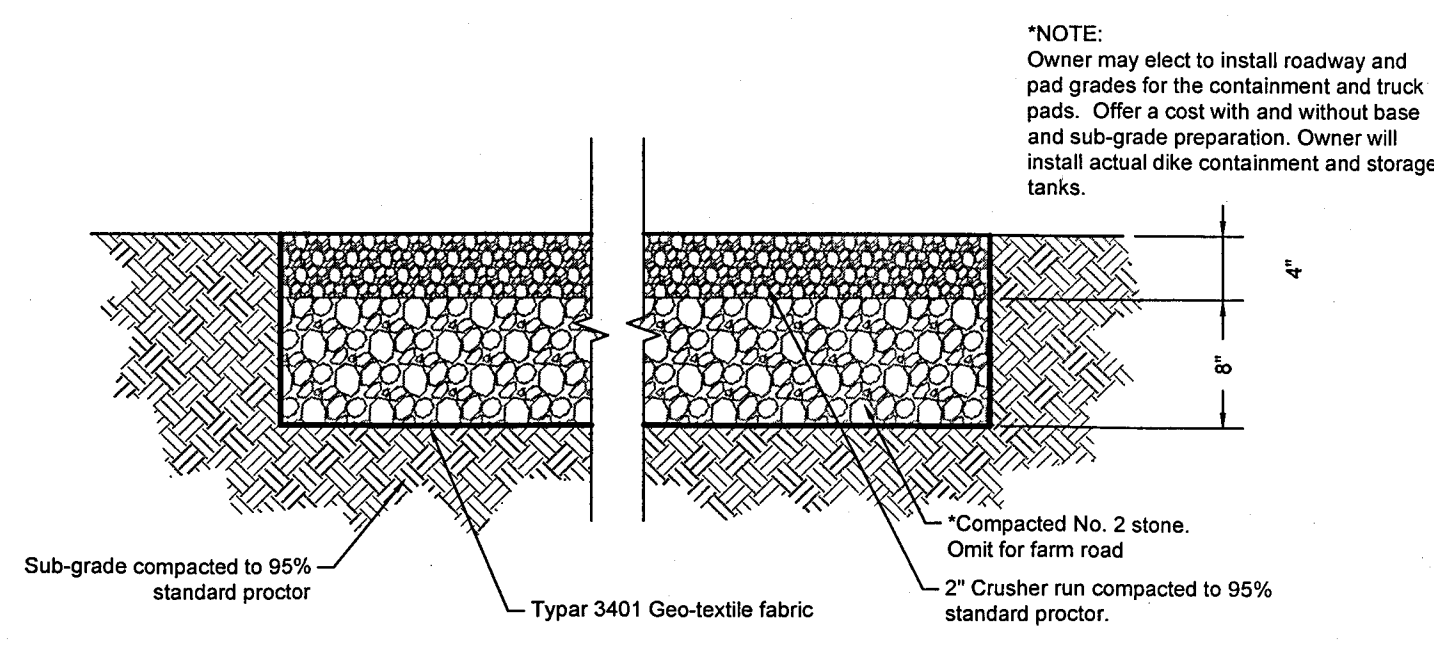

ROADWAY CONSTRUCTION
NO SCALE

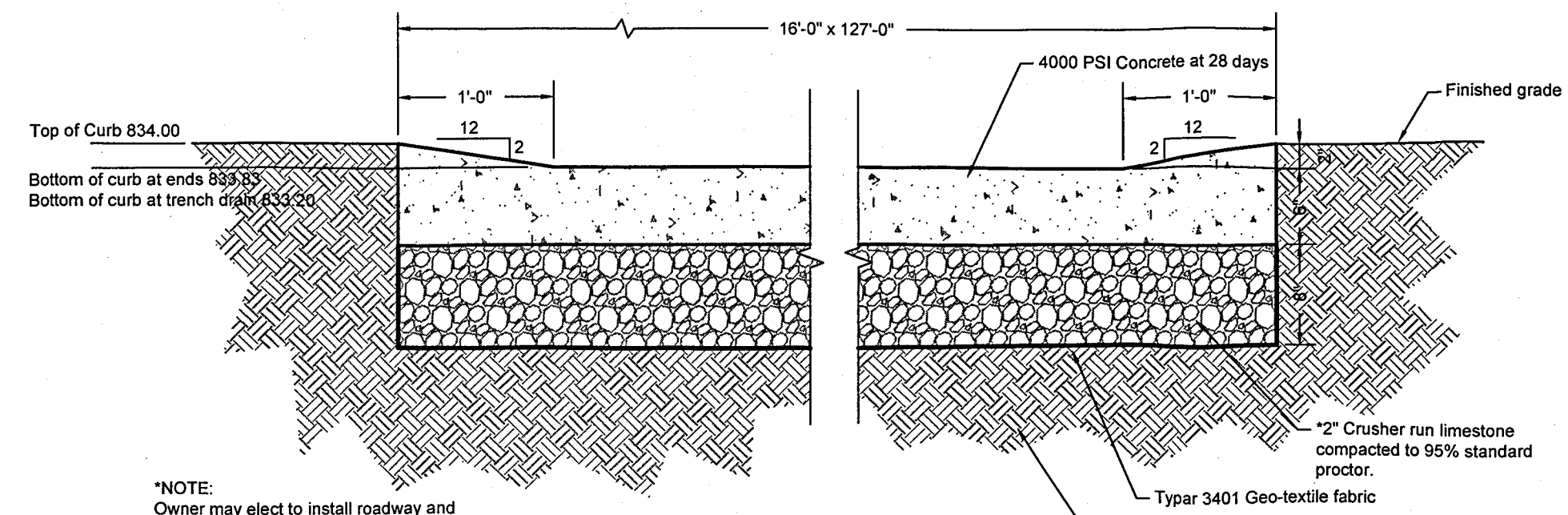

TRUCK PAD
NO SCALE

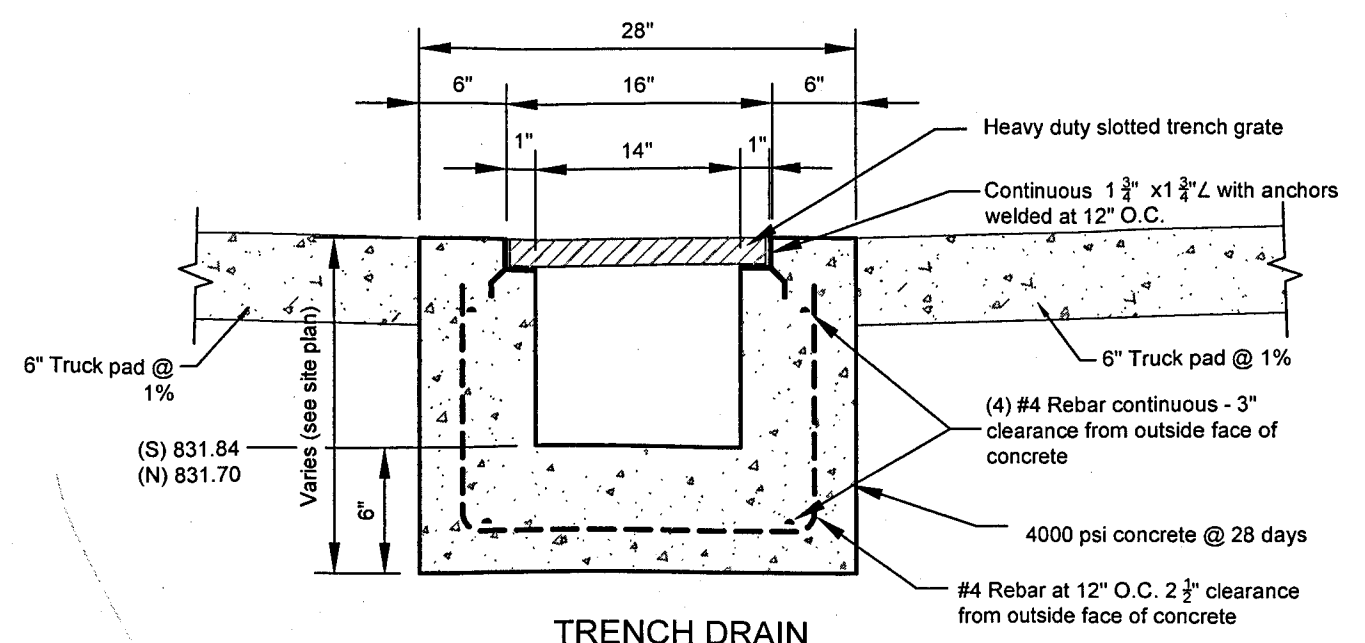

TRENCH DRAIN
NO SCALE

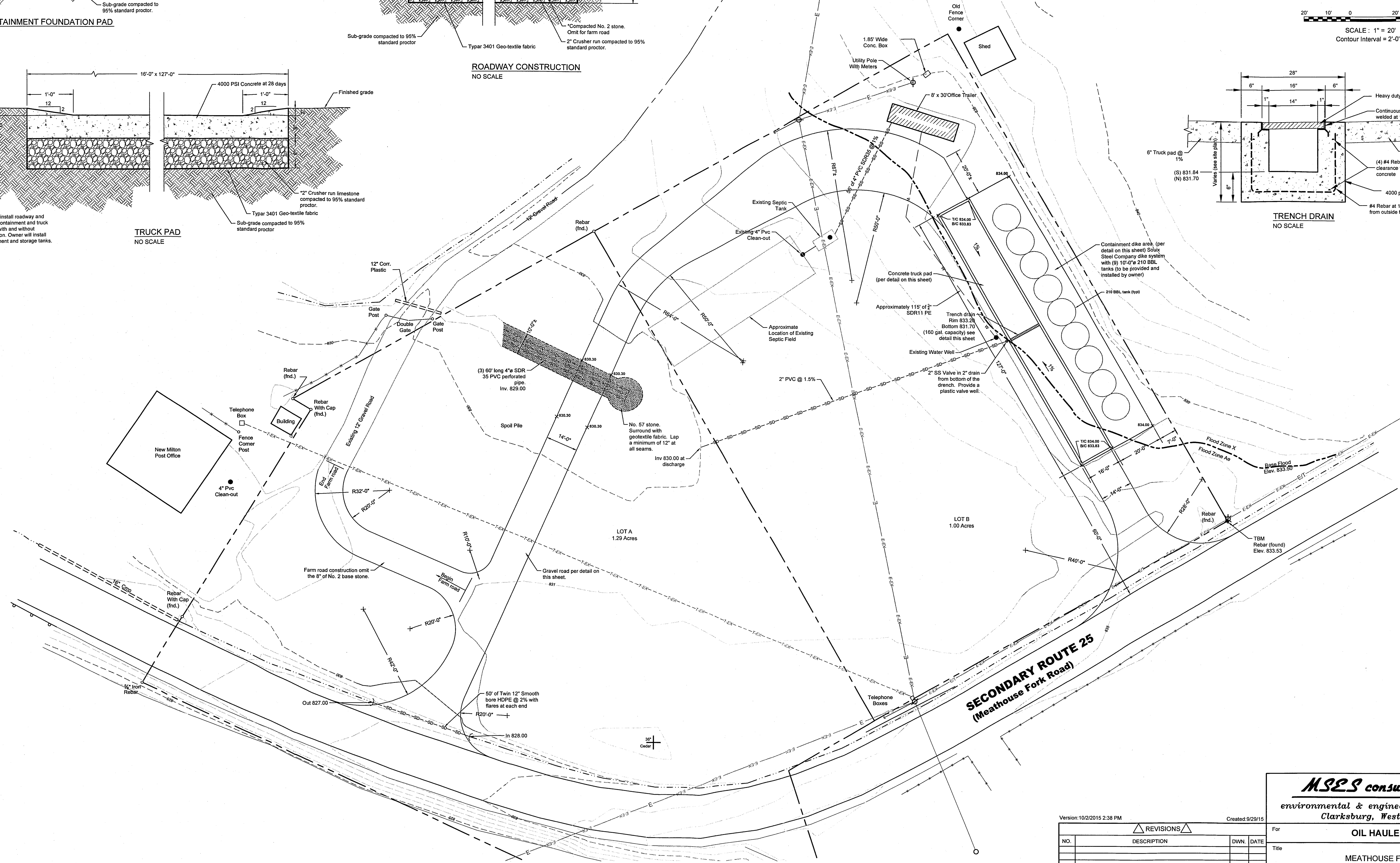
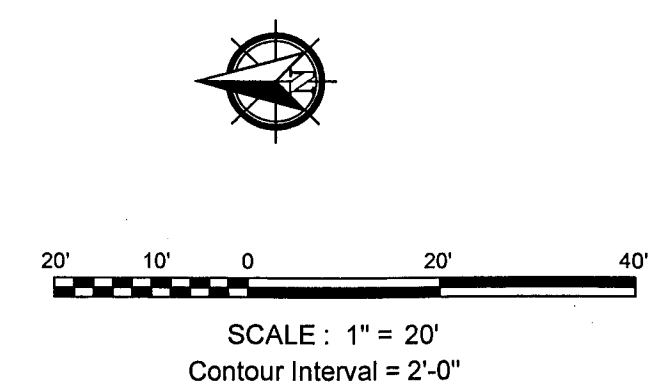

Last saved: Anthony Friend 10/2/2015 1:21 PM
 Created: 9/29/2015 8:38 AM
 Drawings developed from a site survey performed by MSES Consultants, Inc. dated September 2015.

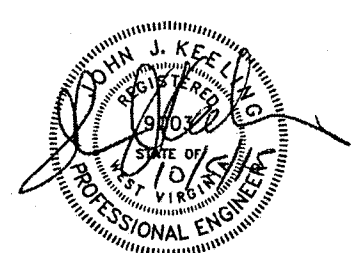

MSES consultants, inc.
environmental & engineering consultants
Clarksburg, West Virginia

OIL HAULERS
MEATHOUSE FORK
SITE PLAN

REVISIONS			
NO.	DESCRIPTION	DWN.	DATE

Drawn	AAF	9/15	Scale	AS SHOWN
Engineer	RDK	9/15	Dwg. No.	C102
Checked	RDK	9/15		